



การไฟฟ้าส่วนภูมิภาค  
บันทึก

จาก กมฟ. \_\_\_\_\_ ถึง กจน. \_\_\_\_\_  
เลขที่ กมฟ.(จฟ) 963/2552 วันที่ - 8 ต.ค. 2552  
เรื่อง สเปกขรรรคสำหรับการจัดซื้อตามงบลงทุนประจำปี  
อ้างอิง \_\_\_\_\_

เรียน อก.จน.

กมฟ. ขอส่งสเปกขรรรคสำหรับการจัดซื้อตามงบลงทุนประจำปี ที่ไม่มีการแก้ไขให้ กจน. ใช้เป็นสเปกอ้างอิงในการดำเนินการจัดซื้อได้เลย ดังนี้ :

สเปคอ้างอิงเลขที่ : RTES-169/2552  
สำหรับการจัดซื้อ วัสดุเลขที่ \_\_\_\_\_ : \_\_\_\_\_  
รายการที่ 1 วัสดุเลขที่ - Three-Phase Meter Test Station, Up to 20 Meters  
-----  
-----

อนึ่ง กมฟ. ได้จัดทำสเปก Three-Phase Meter Test Station, Up to 20 Meters ดังกล่าว โดยได้รับอนุมัติ จาก กพท. แล้ว ตามอนุมัติ รพค.(ว) ลว. 29 ก.ย. 2552 ส่วนสเปกเฉพาะราย หรือจำเป็นต้องแก้ไขมาตรฐาน กมฟ. จะจัดส่งให้ต่างหากต่อไป

จึงเรียนมาเพื่อโปรดพิจารณาดำเนินการต่อไป และ โปรดส่งสเปคอ้างอิงเลขที่ R-999/2545 ขอยกเลิกคืน กมฟ. ด้วย

  
(นายสมเกียรติ รุ่งโรจนารักษ์)  
รท.มฟ.ปฏิบัติแทนแทน อก.มฟ.

ผู้ร่าง.....  
ผู้พิมพ์.....  
ผู้ตรวจทาน.....  
ทศ. .... 2 ต.ค. 52  
วศท.8/วศท.9 .....  
รท./อก. ....



# PROVINCIAL ELECTRICITY AUTHORITY

## POWER SYSTEM STANDARD DIVISION

Specification No.: RTES-169/2552 : Three-Phase Meter Test Station, Up To 20 Meters

Page 1 of 10

### C3 Schedule of detailed requirement

# COPY

Invitation to Bid No.:

Item	PEA Material No.	Quantity	Description
1	-	system(s)	<p><b>Three-phase meter test station;</b> automatic certification, semi-automatic adjustment and manual setting of test current, voltage, power factor, and for simultaneously testing the large batches of three-phase energy meters of electromechanical and electronic types of class 0.2, 0.5, 1 and 2; up to twenty (20) units or more at the same time using the energy comparison method; suitable for testing of the following kinds of meters :</p> <ul style="list-style-type: none"> <li>- three-phase 3-wire and three-phase 4-wire meters for active energy (three-phase kilowatt-hour meters)</li> <li>- three-phase 3-wire and three-phase 4-wire meters for reactive energy, all type of connections (three-phase kilovar-hour meters); each system shall be consisted of:</li> </ul> <p>1.1 <u>1</u> unit      Meter test unit, with:</p> <p style="padding-left: 40px;">1 set      Electronic power source unit:</p> <p style="padding-left: 80px;">Main switch and emergency off switch</p> <p style="padding-left: 80px;">Input voltage      : 3x220/380 V, 50 Hz</p> <p style="padding-left: 80px;">Test frequency circuit</p> <p style="padding-left: 120px;">: 45 to 65 Hz adjustable in steps of 0.1 Hz</p> <p style="padding-left: 80px;">Test voltage circuit:</p> <ul style="list-style-type: none"> <li>- range      : 40 to 300 V (phase-neutral), or better</li> <li>- accuracy      : ≤ 0.05 % of range, or better</li> <li>- output power      : not less than 3x1,000 VA</li> <li>- stability      : ≤ 50 ppm/h</li> <li>- distortion factor      : &lt; 0.5 %</li> <li>- power efficiency      : ≥ 85 %</li> </ul> <p style="padding-left: 80px;">Electronic overload and short-circuit protection</p> <p style="padding-left: 80px;">Test current circuit:</p> <ul style="list-style-type: none"> <li>- range      : 1 mA to 120 A, or better</li> <li>- accuracy      : ≤ 0.05 % of range, or better</li> <li>- output power      : not less than 3x1,500 VA</li> <li>- stability      : ≤ 50 ppm/h</li> </ul>



# PROVINCIAL ELECTRICITY AUTHORITY

## POWER SYSTEM STANDARD DIVISION

Specification No.: RTES-169/2552 : Three-Phase Meter Test Station, Up To 20 Meters

Page 2 of 10

### C3 Schedule of detailed requirement

Invitation to Bid No.:

Item	PEA Material No.	Quantity	Description
			<ul style="list-style-type: none"><li>- distortion factor : &lt; 0.5 %</li><li>- power efficiency : <math>\geq 85</math> %</li><li>Electronic overload circuit and security to safeguard the operation at open current circuit</li><li>Phase angle adjustment:<ul style="list-style-type: none"><li>- range : <math>0^{\circ}</math> to <math>360^{\circ}</math></li><li>- resolution of phase angle setting : <math>0.01^{\circ}</math>, or better</li></ul></li><li><u>1 set</u> Electronic reference standard :<ul style="list-style-type: none"><li>- Voltage :<ul style="list-style-type: none"><li>- range : 60 to 400 V (phase-neutral), or better</li><li>- accuracy : <math>\leq \pm 0.01</math> % of range, or better</li></ul></li><li>- Current :<ul style="list-style-type: none"><li>- range : 10 mA to 120 A, or better</li><li>- accuracy :<ul style="list-style-type: none"><li>- 10 mA to 100 mA, range : <math>\leq \pm 0.02</math> % of range, or better</li><li>- 100 mA to 120 A, range : <math>\leq \pm 0.01</math> % of range, or better</li></ul></li></ul></li><li>- Frequency :<ul style="list-style-type: none"><li>- range : 45 to 65 Hz</li></ul></li></ul></li></ul>
	II		



# PROVINCIAL ELECTRICITY AUTHORITY

## POWER SYSTEM STANDARD DIVISION

Specification No.: RTES-169/2552 : Three-Phase Meter Test Station, Up To 20 Meters

Page 3 of 10

### C3 Schedule of detailed requirement

#### Invitation to Bid No.:

Item	PEA Material No.	Quantity	Description
			<ul style="list-style-type: none"><li>- Error of active and reactive (power/energy) :<ul style="list-style-type: none"><li>- <math>\cos\Phi = 1</math> : <math>\leq \pm 0.02</math> % of range, or better,</li><li>- <math>\cos\Phi = 0.5</math> : <math>\leq \pm 0.04</math> % of range, or better,</li><li>- <math>\sin\Phi = 1</math> : <math>\leq \pm 0.02</math> % of range, or better,</li><li>- <math>\sin\Phi = 0.5</math> : <math>\leq \pm 0.04</math> % of range, or better,</li></ul></li></ul> <p><u>1</u> set. Actual value indicator with digital display (The actual indicator may not be required if the software can show all actual values on 17" LCD monitor separately from display monitor. In this case two(2) monitors shall be required and the values shall be shown on the monitors simultaneously)</p> <p>The following values can be shown:</p> <ul style="list-style-type: none"><li>- 3 test voltages <math>U_1, U_2, U_3</math>,</li><li>- 3 test currents <math>I_1, I_2, I_3</math>,</li><li>- power per phase <math>P_1, P_2, P_3</math>,</li><li>- total power</li><li>- phase angle between voltage/current per phase</li><li>- frequency</li></ul>
	II		1.2 <u>1</u> lot. The meter test rack, consisting of a rack and table. The rack shall be suitable for the suspension twenty (20) meters.

PSD



# PROVINCIAL ELECTRICITY AUTHORITY

## POWER SYSTEM STANDARD DIVISION

Specification No.: RTES-169/2552 : Three-Phase Meter Test Station, Up To 20 Meters

Page 4 of 10

### C3 Schedule of detailed requirement

#### Invitation to Bid No.:

Item	PEA Material No.	Quantity	Description
			<p>1.3 <u>20</u> sets. Test connection of quick connector type for each meter, universal design (for IEC, ANSI and BS meters), adjustable, suitable for bottom-connected of three-phase energy meters of all types in general use in large numbers, used on the meter racks for easy and quick connection of the meter to be tested, with:</p> <ul style="list-style-type: none"><li>- current cables .</li><li>- voltage cables with omega clamps and pins</li><li>- cables for testing emitting pulse contact</li></ul>
			<p>1.4 <u>20</u> sets. Scanning device, of photoelectric scanning head/sensor head, suitable for counting disk revolutions of electromechanical type meters and for detecting LED impulses of electronic type meters. Complete with vertical and horizontal adjustment mechanism.</p>
			<p>1.5 <u>20</u> sets. Error display units, digital type, for individual error display for each meter under test, mounted on the meter rack at each meter test place, with:</p> <ul style="list-style-type: none"><li>- the display is in %</li><li>- test pulse emitting contacts of meters</li></ul>
			<p>1.6 <u>1</u> lot. Current isolation transformers, for simultaneously testing the large batches (up to twenty (20) units or more) of three-phase energy meters with closed links between test voltage and test current circuit. Complete with terminals for easily change connection in case of using current isolation transformers or without current isolation transformers, with:</p> <p>range : 0.5 to 100 A, or better (ratio 1 : 1)</p> <p>accuracy (5 A-100 A) : <math>\leq \pm 0.1</math> % (ratio error)</p> <p>: <math>\leq \pm 2</math> minute (phase error)</p>
	II		

II

PSD



# PROVINCIAL ELECTRICITY AUTHORITY

## POWER SYSTEM STANDARD DIVISION

Specification No.: RTES-169/2552 : Three-Phase Meter Test Station, Up To 20 Meters

Page 5 of 10

### C3 Schedule of detailed requirement

#### Invitation to Bid No.:

Item	PEA Material No.	Quantity	Description
			<p>1.7 <u>1</u> set. Hand-held terminal, for entering of individual meter data (e.g. register readings, serial numbers, etc.) with LASER SCANNER to read bar-code information from meter.</p> <p>Complete with:</p> <ol style="list-style-type: none"><li>1) Protective devices for input and output circuits and for auxiliary supply circuit(s).</li><li>2) Power supply cord and plug.</li><li>3) Internal wirings, interconnection cables and connectors.</li><li>4) Instruction manual with part list and circuit diagram.</li><li>5) Training course, for at least five (5) working days of PEA's personnel, including training for operation and maintenance of the three-phase meter test station,</li><li>6) Certificate of calibration and calibration test report of reference standard meter unit from Accreditation Bodies (PTB, NPL, NIST, or equivalent) or from the laboratories, which have been accredited by such the Accreditation Bodies.</li><li>7) Others according to manufacturer's design, which shall be clearly described.</li></ol>



# PROVINCIAL ELECTRICITY AUTHORITY

## POWER SYSTEM STANDARD DIVISION

Specification No.: RTES-169/2552 : Three-Phase Meter Test Station, Up To 20 Meters

Page 6 of 10

### C3 Schedule of detailed requirement

Invitation to Bid No.:

Item	PEA Material No.	Quantity	Description
	II	1.8	<p>1 set. Microcomputer (Desktop PC), for single-phase 220 VAC 50 Hz power supply, with :</p> <p>CPU : Intel Core 2 Duo processors 2.8 GHz, 3 MB L2 cache, 1066 MHz FSB, or better,</p> <p>Memory : 2 GB DDR2-RAM, or better</p> <p>Hard disk : 250GB SATA Hard Drive 7200 rpm, or more,</p> <p>CD-ROM drive : DVD-RW drive, super multi drive, double layer, or better,</p> <p>Monitor : LCD 17" (1024x768 Res.), or more</p> <p>Keyboard : 104 keys, or more</p> <p>Mouse : PS/2 or USB mouse</p> <p>Network adapter : built-in Ethernet card 10/100 Mbps</p> <p>Multimedia : sound card and speakers of not less than 120 W (P.M.P.O.),</p> <p>Port &amp; Slot : parallel &amp; serial ports, mouse &amp; keyboard ports, audio port and USB port,</p> <p>Complete with:</p> <ol style="list-style-type: none"><li>1) Software package(s), for installation and operation (Microsoft Windows XP/Vista, or later version, Thai Edition).</li><li>2) Software package(s), for automatic testing, semi-automatic testing, manual testing and recording data results.</li><li>3) Interconnecting cables, power supply cord and plug.</li><li>4) Interconnecting cables between the three-phase meter test station (1.1) and the computer system (1.8).</li><li>5) Laser printer, 600 x 600 dpi, 10 ppm, paper sizes A4, or better.</li><li>6) Desk and chair, for personal computer system.</li><li>7) Instruction manual.</li><li>8) Others according to manufacturer's design, which shall be clearly described</li></ol>

PSD



# PROVINCIAL ELECTRICITY AUTHORITY

## POWER SYSTEM STANDARD DIVISION

Specification No.: RTES-169/2552 : Three-Phase Meter Test Station, Up To 20 Meters

Page 7 of 10

### C3 Schedule of detailed requirement

Invitation to Bid No.:

Item	PEA Material No.	Quantity	Description
			<p>1.9 <u>  1  </u> set. Uninterruptible power supply (UPS), for single-phase 220 VAC 50 Hz power supply, with:</p> <p>Standard : TIS 1291</p> <p>System : true on-line</p> <p>Rated power : not less than 500 VA</p> <p>Input voltage : 220 VAC <math>\pm</math> 10 % or better</p> <p>Input frequency : 50 Hz <math>\pm</math> 2 % or better</p> <p>Output voltage : 220 VAC <math>\pm</math> 1 % or better</p> <p>Output frequency : 50 Hz <math>\pm</math> 1 % or better</p> <p>Wave form : sine wave</p> <p>Total harmonic distortion : not more than 5 %</p> <p>Overload capacity : not less than 125 % for 30 seconds</p> <p>Battery type : sealed lead acid (maintenance free)</p> <p>Back-up time (full load) : not less than 10 minutes</p> <p>Noise : not more than 50 dBA at 1 m distance</p> <p>Alarm or Indicator : - low battery - inverter failure - overload</p> <p>Operating temperature : 0 to 40 C, or better</p> <p>Complete with:</p> <ol style="list-style-type: none"><li>1) Interconnecting cables, power supply cord and plug.</li><li>2) Instruction manual.</li><li>3) Others according to manufacturer's design, which shall be clearly described.</li></ol>





# PROVINCIAL ELECTRICITY AUTHORITY

## POWER SYSTEM STANDARD DIVISION

Specification No.: RTES-169/2552 : Three-Phase Meter Test Station, Up To 20 Meters

Page 8 of 10

### C3 Schedule of detailed requirement

Invitation to Bid No.:

Item	PEA Material No.	Quantity	Description
			<p>1.10 <u>1</u> set. Surge protective device, voltage limiting type, for install at the input of a power supply line from lightning protection zone 1 into lightning protection zone 2 (LPZ1 into LPZ2, according to IEC 62305), such as the subdistribution board of the building, with:</p> <p>Test standard : IEC 61643-1 class II (E DIN VDE 0675-6 and E DIN VDE 0675-6/A1, class C), or equivalent</p> <p>Number of pole : 4 units of single pole combination</p> <p>Maximum continuous operating voltage, <math>U_c</math> (operating frequency 50 Hz) : not less than 250 V / pole</p> <p>Nominal discharge current, <math>I_n</math> (8/20) <math>\mu</math>s : not less than 15 kA / pole</p> <p>Maximum discharge current, <math>I_{max}</math> (8/20) <math>\mu</math>s : not less than 40 kA / pole</p> <p>Voltage protection level, <math>U_p</math> (L-PE) : not more than 1.5 kV</p> <p>Response time : not more than 25 ns</p> <p>Degree of protection : IP 20, or better</p> <p>Operating temperature range : up to 80 °C, or better</p> <p>Conductor size : 4 - 25 mm<sup>2</sup>, or better</p> <p>Installation : mounting on standard size rail</p> <p>Complete with status indicator, installation equipment, back up fuses or circuit breaker, installation manual and other accessories according to manufacturer's design and auxiliary equipment necessary to complete.</p>
2	-	lot(s)	Spare part, for ten-year operation of the three-phase meter test station in Item 1 (Give details).
3	-	lot(s)	Special tools, for installation and maintenance of the three-phase meter test station in Item 1 (Give details).
	II		

PSA



# PROVINCIAL ELECTRICITY AUTHORITY

## POWER SYSTEM STANDARD DIVISION

Specification No.: RTES-169/2552 : Three-Phase Meter Test Station, Up To 20 Meters

Page 9 of 10

### C3 Schedule of detailed requirement

Invitation to Bid No.:

Item	PEA Material No.	Quantity	Description
4	-	lot(s)	<p>Optional accessories for Item 1.</p> <p><b>Note:</b></p> <ol style="list-style-type: none"><li>1. Bidders have to quote the Unit Costs; and portion of each Item shall not be considered.</li><li>2. The manufacturer of meter test unit shall have at least ten (10) years manufacturing experience and at least one (1) unit of same model and same accuracy class of the proposed meter test unit has been supplied in the last five (5) years.</li><li>3. Bidders have to submit documents in English and/or Thai with the bid as follows :<ol style="list-style-type: none"><li>3.1 Certificate of calibration and calibration test report of meter test unit having same model and same accuracy class as the proposed meter test unit from Accreditation Bodies (PTB, NPL, NIST, or equivalent) or from the laboratories, which have been accredited by such the Accreditation Bodies.</li><li>3.2 Certification letter from customer that documents his satisfaction of meter test unit having same model and same accuracy class as the proposed meter test unit.</li><li>3.3 Sufficient references describing the previous experience of the suppliers (e.g. list of supply of equipment and/or materials having the same or similar design as proposed, field experience, the registration of TISI, the copies of license, and/or the inspection to supplier's factory by PEA's inspectors, etc.) to the satisfaction of PEA.</li></ol></li><li>4. Bidders have to quote recommended spare parts, special tools and optional accessories with their lists of quantities and itemized prices, if any; PEA reserves the right to purchase some or all of items, to adjust their quantities, or to cancel them.</li><li>5. Evaluation and comparison of bid price shall not include the spare part, special tools and optional accessories.</li></ol>



# PROVINCIAL ELECTRICITY AUTHORITY

## POWER SYSTEM STANDARD DIVISION

Specification No.: RTES-169/2552 : Three-Phase Meter Test Station, Up To 20 Meters

Page 10 of 10

### C3 Schedule of detailed requirement

Invitation to Bid No.:

Item	PEA Material No.	Quantity	Description
	II		<p>6. PEA shall purchase the three-phase meter test station, spare parts in Item 2, special tools in Item 3 and optional accessories in Item 4 from one (1) bidder or one (1) manufacturer.</p> <p>7. The three-phase meter test station shall be furnished with auxiliary equipment and accessories not specified in these specifications, but necessary to complete the sound function.</p>

SD



PROVINCIAL ELECTRICITY AUTHORITY  
POWER SYSTEM STANDARD DIVISION

Specification No. RTES-169/2552 : Three-Phase Meter Test Station, Up To 20 Meters

C4 Price schedule  
Invitation to Bid No.

Manufacturer :  
Country of origin :  
Trade-mark :

Item	PEA Material No.	Catalogue No.	Description	Quantity	Unit Cost (See details & conditions attached)	Total Cost (See details & conditions attached)
1	-		<p><b>Three-phase meter test station;</b> automatic certification, semi-automatic adjustment and manual setting of test current, voltage, power factor, and for simultaneously testing the large batches of three-phase energy meters of electromechanical and electronic types of class 0.2, 0.5, 1 and 2; up to twenty (20) units or more at the same time using the energy comparison method; suitable for testing of the following kinds of meters :</p> <ul style="list-style-type: none"><li>- three-phase 3-wire and three-phase 4-wire meters for active energy (three-phase kilowatt-hour meters)</li><li>- three-phase 3-wire and three-phase 4-wire meters for reactive energy, all type of connections (three-phase kilovar-hour meters); each system shall be consisted of:</li></ul>	system(s)		

II



**PROVINCIAL ELECTRICITY AUTHORITY**  
**POWER SYSTEM STANDARD DIVISION**

Specification No. RTES-169/2552 : Three-Phase Meter Test Station, Up To 20 Meters

C4 Price schedule

Invitation to Bid No.

Manufacturer :

Country of origin :

Trade-mark :

Item	PEA Material No.	Catalogue No.	Description	Quantity	Unit Cost (See details & conditions attached)	Total Cost (See details & conditions attached)
			1.1 Meter test unit, with: Electronic power source unit: Main switch and emergency off switch Input voltage : ..... Test frequency circuit : ..... Test voltage circuit: - range : ..... - accuracy : ..... - output power : ..... - stability : ..... - distortion factor : ..... - power efficiency : ..... Electronic overload and short-circuit protection	1 unit 1 set		
	II					

**PSD**



**PROVINCIAL ELECTRICITY AUTHORITY**  
**POWER SYSTEM STANDARD DIVISION**

Specification No. RTES-169/2552 : Three-Phase Meter Test Station, Up To 20 Meters

C4 Price schedule  
Invitation to Bid No.

Manufacturer :  
Country of origin :  
Trade-mark :

Item	PEA Material No.	Catalogue No.	Description	Quantity	Unit Cost (See details & conditions attached)	Total Cost (See details & conditions attached)
			Test current circuit: - range : ..... - accuracy : ..... - output power : ..... - stability : ..... - distortion factor : ..... - power efficiency : ..... Electronic overload circuit and security to safeguard the operation at open current circuit Phase angle adjustment: - range : ..... - resolution of phase angle setting : .....			
	II					



**PROVINCIAL ELECTRICITY AUTHORITY**  
**POWER SYSTEM STANDARD DIVISION**

Specification No. RTES-169/2552 : Three-Phase Meter Test Station, Up To 20 Meters

C4 Price schedule

Invitation to Bid No.

Manufacturer :

Country of origin :

Trade-mark :

Item	PEA Material No.	Catalogue No.	Description	Quantity	Unit Cost (See details & conditions attached)	Total Cost (See details & conditions attached)
	II		Electronic reference standard :  - Voltage : - range : ..... - accuracy : .....  - Current : - range : ..... - accuracy : ..... - 10 mA to 100 mA, range : ..... - 100 mA to 120 A, range : .....  - Frequency : - range : .....	1 set		



PROVINCIAL ELECTRICITY AUTHORITY  
POWER SYSTEM STANDARD DIVISION

Specification No. RTES-169/2552 : Three-Phase Meter Test Station, Up To 20 Meters

C4 Price schedule

Invitation to Bid No.

Manufacturer :

Country of origin :

Trade-mark :

Item	PEA Material No.	Catalogue No.	Description	Quantity	Unit Cost (See details & conditions attached)	Total Cost (See details & conditions attached)
	II		<p>- Error of active and reactive (power/energy) :</p> <ul style="list-style-type: none"><li>- <math>\cos\phi = 1</math> : .....</li><li>- <math>\cos\phi = 0.5</math> : .....</li><li>- <math>\sin\phi = 1</math> : .....</li><li>- <math>\sin\phi = 0.5</math> : .....</li></ul>			

333





PROVINCIAL ELECTRICITY AUTHORITY  
POWER SYSTEM STANDARD DIVISION

Specification No. RTES-169/2552 : Three-Phase Meter Test Station, Up To 20 Meters

C4 Price schedule

Invitation to Bid No.

Manufacturer :

Country of origin :

Trade-mark :

Item	PEA Material No.	Catalogue No.	Description	Quantity	Unit Cost (See details & conditions attached)	Total Cost (See details & conditions attached)
			<p>Actual value indicator with digital display (The actual indicator may not be required if the software can show all actual values on 17" LCD monitor separately from display monitor. In this case two(2) monitors shall be required and the values shall be shown on the monitors simultaneously) The following values can be shown:</p> <ul style="list-style-type: none"><li>- 3 test voltages <math>U_1, U_2, U_3</math></li><li>- 3 test currents <math>I_1, I_2, I_3</math></li><li>- power per phase <math>P_1, P_2, P_3</math></li><li>- total power</li><li>- phase angle between voltage/current per phase</li><li>- frequency</li></ul>	1 set		
	II		<p>1.2 The meter test rack, consisting of a rack and table. The rack shall be suitable for the suspension twenty (20) meters.</p>	1 lot		

PC



PROVINCIAL ELECTRICITY AUTHORITY  
POWER SYSTEM STANDARD DIVISION

Specification No. RTES-169/2552 : Three-Phase Meter Test Station, Up To 20 Meters

C4 Price schedule

Invitation to Bid No.

Manufacturer :

Country of origin :

Trade-mark :

Item	PEA Material No.	Catalogue No.	Description	Quantity	Unit Cost (See details & conditions attached)	Total Cost (See details & conditions attached)
			1.3 Test connection of quick connector type for each meter, universal design (for IEC, ANSI and BS meters), adjustable, suitable for bottom-connected of three-phase energy meters of all types in general use in large numbers, used on the meter racks for easy and quick connection of the meter to be tested, with: <ul style="list-style-type: none"><li>- current cables</li><li>- voltage cables with omega clamps and pins</li><li>- cables for testing emitting pulse contact</li></ul>	20 sets		
			1.4 Scanning device, of photoelectric scanning head/sensor head, suitable for counting disk revolutions of electromechanical type meters and for detecting LED impulses of electronic type meters. Complete with vertical and horizontal adjustment mechanism.	20 sets		

II

PC-



**PROVINCIAL ELECTRICITY AUTHORITY**  
**POWER SYSTEM STANDARD DIVISION**

Specification No. RTES-169/2552 : Three-Phase Meter Test Station, Up To 20 Meters

C4 Price schedule  
 Invitation to Bid No.

Manufacturer :  
 Country of origin :  
 Trade-mark :

Item	PEA Material No.	Catalogue No.	Description	Quantity	Unit Cost (See details & conditions attached)	Total Cost (See details & conditions attached)
			1.5 Error display units, digital type, for individual error display for each meter under test, mounted on the meter rack at each meter test place, with: <ul style="list-style-type: none"> <li>- the display is in %</li> <li>- test pulse emitting contacts of meters</li> </ul>	20 sets		
			1.6 Current isolation transformers, for simultaneously testing the large batches (up to twenty (20) units or more) of three-phase energy meters with closed links between test voltage and test current circuit. Complete with terminals for easily change connection in case of using current isolation transformers or without current isolation transformers, with: <p style="text-align: right;">: .....</p> <p style="text-align: right;">range : .....</p> <p style="text-align: right;">accuracy (5 A-100 A) : .....</p>	1 lot		

II

300



**PROVINCIAL ELECTRICITY AUTHORITY**  
**POWER SYSTEM STANDARD DIVISION**

Specification No. RTES-169/2552 : Three-Phase Meter Test Station, Up To 20 Meters

C4 Price schedule

Invitation to Bid No.

Manufacturer :

Country of origin :

Trade-mark :

Item	PEA Material No.	Catalogue No.	Description	Quantity	Unit Cost (See details & conditions attached)	Total Cost (See details & conditions attached)
II			1.7 Hand-held terminal, for entering of individual meter data (e.g. register readings, serial numbers, etc.) with LASER SCANNER to read bar-code information from meter.  Complete with: 1) ..... 2) ..... 3) ..... 4) ..... 5) ..... 6) ..... 7) .....	1 set		

PS 7



**PROVINCIAL ELECTRICITY AUTHORITY  
POWER SYSTEM STANDARD DIVISION**

Specification No. RTES-169/2552 : Three-Phase Meter Test Station, Up To 20 Meters

Page 10 of 17

C4 Price schedule

Invitation to Bid No.

Manufacturer :

Country of origin :

Trade-mark :

Item	PEA Material No.	Catalogue No.	Description	Quantity	Unit Cost (See details & conditions attached)	Total Cost (See details & conditions attached)
	II		1.8 Microcomputer (Desktop PC), for single-phase 220 VAC 50 Hz power supply, with : CPU : ..... Memory : ..... Hard disk : ..... CD-ROM drive : ..... Monitor : ..... Keyboard : ..... Mouse : ..... Network adapter : ..... Multimedia : ..... Port & Slot : .....	1 set		

**PSD**



**PROVINCIAL ELECTRICITY AUTHORITY**  
**POWER SYSTEM STANDARD DIVISION**

Specification No. RTES-169/2552 : Three-Phase Meter Test Station, Up To 20 Meters

C4 Price schedule

Invitation to Bid No.

Manufacturer :

Country of origin :

Trade-mark :

Item	PEA Material No.	Catalogue No.	Description	Quantity	Unit Cost (See details & conditions attached)	Total Cost (See details & conditions attached)
	II		Complete with: 1) ..... 2) ..... 3) ..... 4) ..... 5) ..... 6) ..... 7) ..... 8) .....			



**PROVINCIAL ELECTRICITY AUTHORITY**  
**POWER SYSTEM STANDARD DIVISION**

Specification No. RTES-169/2552 : Three-Phase Meter Test Station, Up To 20 Meters

Page 12 of 17

C4 Price schedule

Invitation to Bid No.

Manufacturer :

Country of origin :

Trade-mark :

Item	PEA Material No.	Catalogue No.	Description	Quantity	Unit Cost (See details & conditions attached)	Total Cost (See details & conditions attached)
	II		1.9 Uninterruptible power supply (UPS), for single-phase 220 VAC 50 Hz power supply, with: Standard : ..... System : ..... Rated power : ..... Input voltage : ..... Input frequency : ..... Output voltage : ..... Output frequency : ..... Wave form : ..... Total harmonic distortion : ..... Overload capacity : ..... Battery type : ..... Back-up time (full load) : ..... Noise : .....	1 set		

PCP



**PROVINCIAL ELECTRICITY AUTHORITY  
POWER SYSTEM STANDARD DIVISION**

Specification No. RTES-169/2552 : Three-Phase Meter Test Station, Up To 20 Meters

C4 Price schedule

Invitation to Bid No.

Manufacturer :

Country of origin :

Trade-mark :

Item	PEA Material No.	Catalogue No.	Description	Quantity	Unit Cost (See details & conditions attached)	Total Cost (See details & conditions attached)
			Alarm or Indicator : ..... ..... .....  Operating temperature : .....  Complete with: 1) ..... 2) ..... 3) .....			
	II					





**PROVINCIAL ELECTRICITY AUTHORITY**  
**POWER SYSTEM STANDARD DIVISION**

Specification No. RTES-169/2552 : Three-Phase Meter Test Station, Up To 20 Meters

C4 Price schedule

Invitation to Bid No.

Manufacturer :

Country of origin :

Trade-mark :

Item	PEA Material No.	Catalogue No.	Description	Quantity	Unit Cost (See details & conditions attached)	Total Cost (See details & conditions attached)
	II		<p>1.10 Surge protective device, voltage limiting type, for install at the input of a power supply line from lightning protection zone 1 into lightning protection zone 2 (LPZ1 into LPZ2, according to IEC 62305), such as the subdistribution board of the building, with:</p> <p>Test standard : .....</p> <p>Number of pole : .....</p> <p>Maximum continuous operating voltage, <math>U_c</math> (operating frequency 50 Hz)</p> <p>Nominal discharge current, <math>I_n</math> : .....</p> <p>(8/20) <math>\mu</math>s</p> <p>Maximum discharge current, <math>I_{max}</math> : .....</p> <p>(8/20) <math>\mu</math>s</p>	1 set		



**PROVINCIAL ELECTRICITY AUTHORITY**  
**POWER SYSTEM STANDARD DIVISION**

Specification No. RTES-169/2552 : Three-Phase Meter Test Station, Up To 20 Meters

C4 Price schedule

Invitation to Bid No.

Manufacturer :

Country of origin :

Trade-mark :

Item	PEA Material No.	Catalogue No.	Description	Quantity	Unit Cost (See details & conditions attached)	Total Cost (See details & conditions attached)
			Voltage protection level, : ..... U <sub>p</sub> (L-PE) Response time : ..... Degree of protection : ..... Operating temperature range : ..... Conductor size : ..... installation : ..... Complete with : 1) ..... 2) ..... 3) ..... 4) ..... 5) .....			
II				<b>Total of Item 1</b>		



**PROVINCIAL ELECTRICITY AUTHORITY**  
**POWER SYSTEM STANDARD DIVISION**

Specification No. RTES-169/2552 : Three-Phase Meter Test Station, Up To 20 Meters

Page 16 of 17

C4 Price schedule

Invitation to Bid No.

Manufacturer :

Country of origin :

Trade-mark :

Item	PEA Material No.	Catalogue No.	Description	Quantity	Unit Cost (See details & conditions attached)	Total Cost (See details & conditions attached)
2	-		Spare part, for ten-year operation of the three-phase meter test station in Item 1 (Give details). 1) ..... 2) ..... 3) .....	lot(s)		
3	-		Special tools, for installation and maintenance of the three-phase meter test station in Item 1 (Give details). 1) ..... 2) ..... 3) .....	lot(s)		

II

050



PROVINCIAL ELECTRICITY AUTHORITY  
POWER SYSTEM STANDARD DIVISION

Specification No. RTES-169/2552 : Three-Phase Meter Test Station, Up To 20 Meters

C4 Price schedule

Invitation to Bid No.

Manufacturer :

Country of origin :

Trade-mark :

Item	PEA Material No.	Catalogue No.	Description	Quantity	Unit Cost (See details & conditions attached)	Total Cost (See details & conditions attached)
4	-		Optional accessories for Item 1. 1) ..... 2) ..... 3) ..... 4) ..... 5) .....	lot(s)		

II

PSD

Invitation to Bid No.: ต.3กบพ.(จร.)e-bidding027/2567

Specification No.: RTES-169/2552

C3 Schedule of detailed requirement

Item	PEA Material NO.	Quantity	Description
1.		1 Set(s)	<p>1. กำหนดส่งมอบ ที่ อาคารศูนย์ทดสอบมิเตอร์ สำนักงานการไฟฟ้าส่วนภูมิภาค เขต 3 (ภาคใต้) จังหวัดยะลา (แห่งใหม่) ถนนทางหลวงแผ่นดินสา ต่อเขตเทศบาลนครยะลา (409) ต.ท่าสาป อ.เมืองยะลา จ.ยะลา 95000 ภายใน 180 วัน นับถัดจากวันที่ลงนามในสัญญาซื้อขาย ซึ่งภายในงวดสามารถทยอยจัดส่งได้</p> <p>2. การไฟฟ้าส่วนภูมิภาค จะพิจารณาจัดซื้อ/จัดจ้างพัสดุที่ผลิตในประเทศไทย ทั้งนี้ หากผู้เสนอราคาพัสดุที่ผลิตในประเทศไทย มีรายละเอียดคุณลักษณะเฉพาะไม่เป็นไปตามข้อกำหนดของการไฟฟ้าส่วนภูมิภาค หรือไม่มีผู้เสนอพัสดุที่ผลิตในประเทศไทย การไฟฟ้าส่วนภูมิภาค จะพิจารณาจัดซื้อ/จัดจ้างพัสดุที่ผลิตจากต่างประเทศต่อไป</p> <p>พัสดุที่ผลิตในประเทศไทย หมายความว่าถึง ผลิตภัณฑ์ที่ผลิตสำเร็จรูปแล้ว โดยสถานที่ผลิตตั้งอยู่ในประเทศไทย</p>



C3 Schedule of detailed requirement

Invitation to BID No.: ต.3กบพ.(จร.)e-bidding027/2567

Item	PEA Material No.	Quantity	Description
------	------------------	----------	-------------

เอกสารเพิ่มเติม 1 แนบท้าย Specification No.: RTE-169/2552  
THREE PHASE METER TEST STATION (UP TO 20 METERS)  
(ADDENDUM 1)

เอกสารเพิ่มเติม 1 (ADDENDUM 1) นี้ให้ถือเป็นส่วนหนึ่งของรายละเอียดข้อกำหนดทางเทคนิคที่เอกสารนี้ได้แนบอยู่ด้วย

1.ในช่วง 5 (ห้า) ปี ที่ผ่านมา (นับตั้งแต่ที่ส่งมอบ THREE PHASE METER TEST STATION (UP TO 20 METERS) ถึงวันที่เสนอราคา) ผู้ยื่นข้อเสนอราคาต้องมีผลงานในการขาย THREE PHASE METER TEST STATION (UP TO 20 METERS) ในวงเงินไม่น้อยกว่าร้อยละ 30 หรือในวงเงินไม่น้อยกว่า 4,060,650.-บาท (สี่ล้านหกหมื่นหกร้อยห้าสิบบาทถ้วน) รวมภาษีมูลค่าเพิ่ม และเป็นผลงานที่เป็นคู่สัญญาโดยตรงกับหน่วยงานของรัฐ หรือหน่วยงานเอกชนที่ กฟภ. เชื่อถือ

2.ในการยื่นเสนอราคาครั้งนี้ ผู้ยื่นเสนอราคาต้องส่งเอกสาร, หลักฐาน ตามข้อที่ 1 โดยให้คู่สัญญาลงนามรับรองผลงานเสนอต่อคณะกรรมการพิจารณาผลการประกวดราคา ในระบบจัดซื้อจัดจ้างภาครัฐ (EGP)

3.บริษัทผู้เสนอราคา ต้องแสดงผลสัมฤทธิ์ที่ใช้งานจริงตามข้อ 1 ให้กับคณะกรรมการพิจารณาผลการประกวดราคา เพื่อประกอบการจัดซื้อ ทั้งนี้ค่าใช้จ่ายดังกล่าวผู้เสนอราคาเป็นผู้รับผิดชอบ

4.ผู้ยื่นข้อเสนอจะต้องส่งแคตตาล็อก และหรือรายละเอียดคุณลักษณะเฉพาะของพัสดุ THREE PHASE METER TEST STATION (UP TO 20 METERS) RTE-169/2552 มาพร้อมการเสนอราคา เพื่อประกอบการพิจารณา หลักฐานดังกล่าวนี้ กฟต.3 จะยึดไว้เป็นเอกสารของทางราชการ

สำหรับแคตตาล็อกที่แนบให้พิจารณา หากเป็นสำเนาจะต้องรับรองสำเนาถูกต้องโดยผู้มีอำนาจทำนิติกรรมแทนนิติบุคคล หากคณะกรรมการพิจารณาผลการประกวดราคาอิเล็กทรอนิกส์ มีความประสงค์จะขอต้นฉบับแคตตาล็อกผู้ยื่นข้อเสนอ จะต้องนำต้นฉบับมาให้กับคณะกรรมการพิจารณาผลการประกวดราคาอิเล็กทรอนิกส์ตรวจสอบภายใน 5 วัน

5.ผู้ยื่นข้อเสนอจะต้องแสดงหลักฐานโรงงานผู้ผลิตพัสดุ THREE PHASE METER TEST STATION (UP TO 20 METERS) ตามรายละเอียดของข้อกำหนดทางเทคนิคเลขที่ RTE-169/2552 THREE PHASE METER TEST STATION (UP TO 20 METERS) ตามที่ระบุไว้ในหน้า 9 ต้องมีการผลิตพัสดุที่จะเสนอขายอย่างน้อยไม่ต่ำกว่า 10 ปี และมีประวัติการขายพัสดุนั้นที่ผู้ยื่นข้อเสนอจะขาย ภายใน 5 ปี ที่ผ่านมา

6.ผู้ยื่นข้อเสนอจะต้องแนบเอกสาร

(1) เอกสารสอบเทียบ พัดลม THREE PHASE METER TEST STATION (UP TO 20 METERS) จากสถาบันหรือห้องทดสอบที่ได้รับ การรับรองตามรายละเอียดของข้อกำหนดทางเทคนิคเลขที่ RTE-169/2552 THREE PHASE METER TEST STATION (UP TO 20 METERS) ตามที่ระบุไว้ในหน้า 9 ซึ่งเป็นห้องปฏิบัติการสอบเทียบที่ได้รับการรับรองระบบมาตรฐาน มอก.17025 หรือ ISO/IEC 17025 เช่น สถาบันมาตรวิทยาแห่งชาติ หรือ สถาบันไฟฟ้าและอิเล็กทรอนิกส์

(2) ตัวแทนจำหน่ายจะต้องแสดงประวัติการขายพัสดุ THREE PHASE METER TEST STATION (UP TO 20 METERS) ให้ กฟต.3 ใช้ประกอบการพิจารณา ตามรายละเอียดของข้อกำหนดทางเทคนิคเลขที่ RTE-169/2552 THREE PHASE METER TEST STATION (UP TO 20 METERS) ตามที่ระบุไว้ในหน้า 9



C3 Schedule of detailed requirement

Invitation to BID No.: ต.3กบพ.(จร.)e-bidding027/2567

Item	PEA Material No.	Quantity	Description
------	------------------------	----------	-------------

7.การรับประกันความชำรุดบกพร่อง

(1) ผู้ยื่นข้อเสนอที่ได้รับคัดเลือกเป็นคู่สัญญากับ กฟต.3 จะต้องรับประกันความชำรุดบกพร่องของวัสดุที่ซื้อขายที่เกิดขึ้นภายในระยะเวลาไม่น้อยกว่า 3 ปี นับถัดจากวันที่ กฟต.3 ได้รับมอบวัสดุ โดยต้องรีบจัดการซ่อมแซมแก้ไขให้ใช้งานได้ดังเดิมภายใน 30 วัน นับถัดจากวันที่ได้รับแจ้งความชำรุดบกพร่อง

(2) ในระยะเวลารับประกันคู่สัญญากับ กฟต.3 จะต้องดำเนินการสอบเทียบ THREE PHASE METER TEST STATION (UP TO 20 METERS) ให้กับ กฟต.3 อย่างน้อย 2 ครั้ง ภายในระยะเวลารับประกัน 3 ปีตามที่ได้รับแจ้งจาก กฟต.3 โดยกำหนดให้มีระยะเวลาในการดำเนินการส่งมอบเทียบให้แล้วเสร็จ พร้อมส่งคืน กฟต.3 ภายในระยะเวลา 4 เดือน นับถัดจากวันที่ได้รับแจ้งจาก กฟต.3 และจะต้องส่งสอบเทียบกับห้องปฏิบัติการสอบเทียบที่ได้รับการรับรองระบบมาตรฐาน มอก.17025 หรือ ISO/IEC 17025 เช่น สถาบันมาตรวิทยาแห่งชาติ หรือ สถาบันไฟฟ้าและอิเล็กทรอนิกส์

8.ผู้ยื่นข้อเสนอที่ได้รับคัดเลือกเป็นคู่สัญญากับ กฟภ. จะต้องดำเนินการจัดหาพร้อมติดตั้งสายเมนไฟฟ้ารวมถึงบริภัณฑ์ไฟฟ้าและอุปกรณ์อื่นๆ ที่เกี่ยวข้อง ของ THREE PHASE METER TEST STATION (UP TO 20 METERS) ให้กับ กฟภ.

9.THREE PHASE METER TEST STATION (UP TO 20 METERS) จะต้องสามารถทดสอบ 1 Phase Meter In case missing neutral is detected



การไฟฟ้าส่วนภูมิภาค  
PROVINCIAL ELECTRICITY AUTHORITY

# PROVINCIAL ELECTRICITY AUTHORITY

## ELECTRICAL AND MECHANICAL ENGINEERING DIVISION

### ELECTRONIC ENERGY METERS WITH WIRELESS COMMUNICATION

Specification No.: RMTR-038/2564

Approved date: 19/01/2564

Rev. No.: 2

Form No. -

#### 1c.5.3.3 Tamper conditions and anti-tamper features

The 1-phase meters shall have the tampering detection features and shall be operated under the following tamper conditions:

(1) Missing neutral

In case missing neutral is detected as shown in **Figure 9**, the Actual Current shall be recorded. The values of total kWh shall be equal to the Actual current x 230 V x 1 (unity power factor) x Time. The backup power supply shall support up to 60-day-continuous operation in this condition. In this case, the 1-phase meters shall display only Total kWh by pressing the actuator, shall be able to record an event with date and time in the non-volatile memory according to **Annex 2: Table 1B**, but the alarm signal shall not be shown.

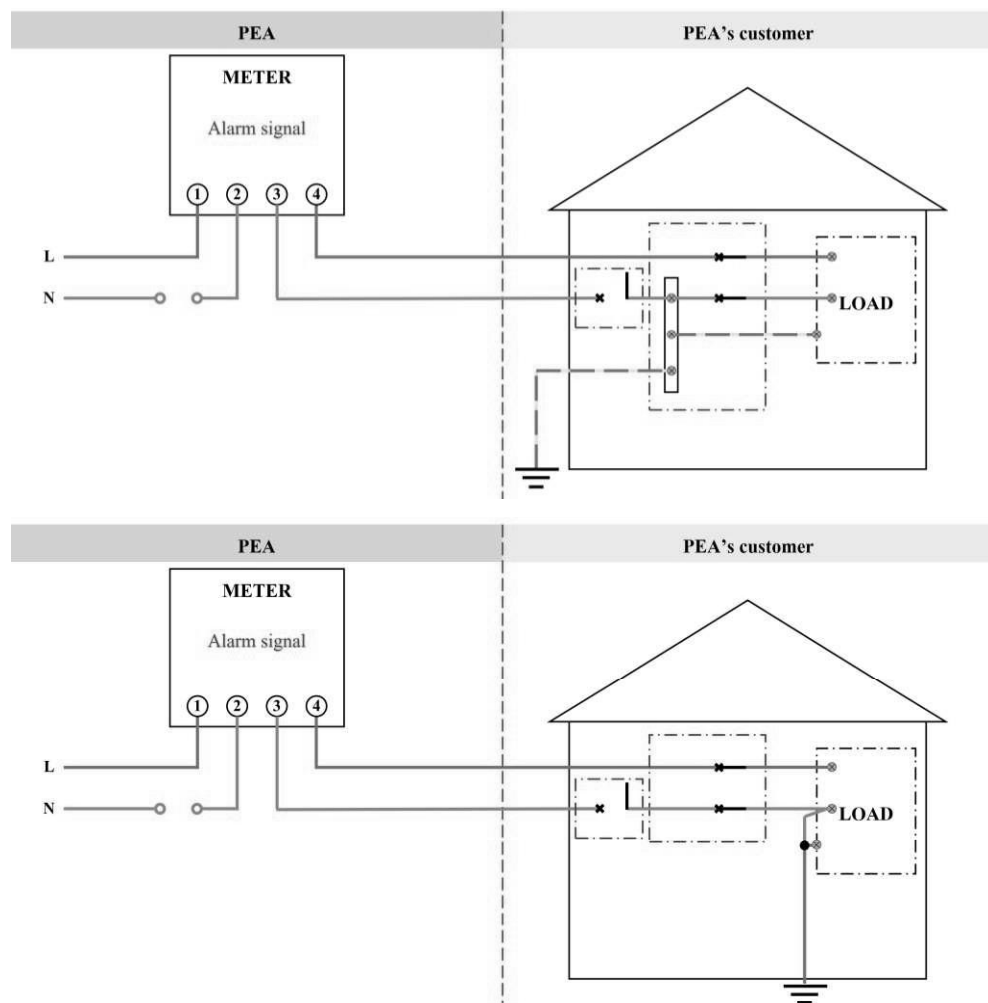

Figure 9: Missing neutral





การไฟฟ้าส่วนภูมิภาค  
PROVINCIAL ELECTRICITY AUTHORITY

## เงื่อนไขเพิ่มเติมประกอบการจัดซื้อ

การไฟฟ้าส่วนภูมิภาค เขต3 (ภาคใต้) จังหวัดยะลา จะพิจารณาจัดซื้อเครื่องมือทดสอบมิเตอร์ สำหรับห้องปฏิบัติการทดสอบมิเตอร์ (Three-Phase Meter Test Station, Up To 20 Meters) ตามเลขที่โครงการ 67039478227 ที่เป็นไปตามมาตรฐานสเปคอ้างอิง RTES-169/2552 เครื่องมือทดสอบมิเตอร์ สำหรับห้องปฏิบัติการทดสอบมิเตอร์ (Three-Phase Meter Test Station, Up To 20 Meters) ตามรายละเอียดดังนี้

1. สำหรับ Notebook Computer ทางหน่วยงาน กฟภ. ต้องการให้ผู้เสนอราคา เสนอชุด Notebook computer ตามสเปคดังต่อไปนี้

- หน่วยประมวลผล Intel Core i7 Gen 12.0 or better
- หน่วยความจำ (RAM) 16 GB DDR4 or better
- ขนาดหน้าจอแสดงผล 14” HD (2880 x 1800) , refresh rate 120 Hz. , Anti-Glare or better
- Video memory: not less than 4 GB , or better
- จัดเก็บข้อมูล 1 TB SSD M.2 or better
- ระบบปฏิบัติการ Windows11 or better (ลิขสิทธิ์)
- ระบบสื่อสารกับอุปกรณ์ภายนอก WiFi, Bluetooth, HDMI, USB ports, etc
- Keyboard ต้องมี Touch pad
- Microsoft Office Professional (ลิขสิทธิ์) (ถาวร)
- น้ำหนักไม่มากกว่า 2.5 กิโลกรัม

การรับประกันสินค้าเป็นระยะเวลา 1 ปี พร้อมให้บริการหลังการขาย รวมถึงการอัปเดตซอฟต์แวร์ที่เกี่ยวข้อง ตลอดระยะเวลาประกัน

2. สำหรับ LASER PRINTER ต้องการให้ผู้เสนอราคา เสนอเป็นชุด ALL IN ONE LASER PRINTER ตามสเปคดังต่อไปนี้

- เทคโนโลยี laser printer black and white or better
- ฟังก์ชัน พิมพ์,สแกนและถ่ายเอกสาร

- หน่วยความจำ 32 MB or better
- ความเร็วในการพิมพ์ A4 Up to 34 ppm (pages per minute) or better
- ความละเอียดในการพิมพ์ Up to 600 x 600 dpi or better
- ความละเอียดในการสแกน Up to 600 x 600 dpi or better
- ความละเอียดในการถ่ายเอกสาร Up to 600 x 600 dpi or better
- มี Automatic Document Feeder (ADF)
- เคส Transportation case

การรับประกันสินค้าเป็นระยะเวลา 1 ปี พร้อมให้บริการหลังการขาย รวมถึงการอัปเดตซอฟต์แวร์ที่เกี่ยวข้อง ตลอดระยะเวลาประกัน

หมายเหตุ - การพิจารณาในแต่ละหัวข้อ อยู่ในดุลยพินิจของคณะกรรมการฯ

- หากคุณสมบัติทางเทคนิคหัวข้อใดใน Spec เลขที่ RTE5-169/2552 และเอกสารเพิ่มเติมแนบท้าย รายละเอียดสเปคเลขที่ RTE5-169/2552 มีความขัดแย้งกัน ให้เลือกคุณสมบัติที่ดีกว่า

หากมีข้อสงสัยประการใด สามารถติดต่อสอบถามได้ที่การไฟฟ้าส่วนภูมิภาค เขต3 (ภาคใต้) จังหวัดยะลา แผนกจัดหาพัสดุ รอง กองบริหารพัสดุ หมายเลขโทรศัพท์ 073-262-692