

INSULATORS

Specification No.: RINS-002/2561

Approved date: 27 JAN 2022

Rev. No.: -

Form No.: -

Page 1 of 1

เอกสารเพิ่มเติมแนบรายละเอียดสเปค
(Addendum)

เอกสารเพิ่มเติมแนบรายละเอียดสเปค (Addendum) นี้ ให้ถือเป็นส่วนหนึ่งของสเปคอ้างอิงเลขที่ RINS-002/2561

1. กำหนดเพิ่มคุณสมบัติห้องปฏิบัติการทดสอบของโรงงานผู้ผลิต สำหรับการทดสอบประจำลูกถ้วยไฟฟ้าแรงสูง ดังนี้

1c.4.1 Manufacturer's laboratory for routine tests

The proposed HV insulators, i.e., line-post type, pin-post type, station post type, suspension type and pin fog type, shall be pass routine tests according to relevant standards at manufacturer's laboratory. The manufacturer's laboratory shall be accredited according to TIS 17025 or ISO/IEC 17025 with the scope of accreditation covered at least the following test items:

- (1) High frequency flashover voltage test or low frequency flashover voltage test
- (2) Tensile strength test or cantilever strength test, depending on the type of the proposed HV insulators

The certification and scope of accreditation of the laboratory shall be submitted with the bid.

2. ยกเลิกตาราง **Critical documents of the proposed insulators shall be submitted with the bid** as follows: (Page 9 of 9) และใช้ตารางดังต่อไปนี้แทน

Critical documents of the proposed insulators shall be submitted with the bid as follows:

Item	Description of document	Conformation	Reference (Page No./Folder)
1	List of routine tests	<input type="checkbox"/> Yes <input type="checkbox"/> No	
2	Design/Type test report and/or test certificate (see 1c.4) or	<input type="checkbox"/> Yes <input type="checkbox"/> No	
	The copy of previous Purchase order (if any) or	<input type="checkbox"/> Yes <input type="checkbox"/> No	
	PEA Product Acceptance certificate (if any) or	<input type="checkbox"/> Yes <input type="checkbox"/> No	
	Product lists certificate (if any)	<input type="checkbox"/> Yes <input type="checkbox"/> No	
3	Certification and scope of accreditation according to TIS 17025 or ISO/IEC 17025 of manufacturer's laboratory	<input type="checkbox"/> Yes <input type="checkbox"/> No	
4	Characteristics of the proposed insulators (see 2a)	<input type="checkbox"/> Yes <input type="checkbox"/> No	
5	Detail drawing(s) with dimension and tolerances in mm (see 2b)	<input type="checkbox"/> Yes <input type="checkbox"/> No	
6	Packing detail (see 2c)	<input type="checkbox"/> Yes <input type="checkbox"/> No	

Note: The bidders who do not submit all critical documents mentioned in the above table with the bid will be rejected.

การกำหนดระยะเวลาในการส่งรายงานผลการทดสอบเฉพาะแบบ (Type test report)

และระยะเวลาในการจัดส่งตัวอย่างเพื่อประกอบการพิจารณาจัดหา

Specification No.: -

Approved date: 21/12/2560

Rev. No.: -

Form No.: -

Page 1 of 1

เอกสารเพิ่มเติมแนบท้ายรายละเอียดสเปก
(ADDENDUM)

เอกสารเพิ่มเติม (ADDENDUM) นี้ ให้ถือเป็นส่วนหนึ่งของรายละเอียดสเปกที่เอกสารฯ นี้ได้แนบอยู่ด้วย

1. การกำหนดระยะเวลาในการส่งรายงานผลการทดสอบเฉพาะแบบ (Type test report)

หากรายละเอียดสเปกกำหนดให้ผู้เสนอราคาจะต้องจัดส่งรายงานผลการทดสอบเฉพาะแบบ (Type test report) หรือหนังสือรับรองผลการทดสอบเฉพาะแบบ (Type test certificates) “ให้ผู้เสนอราคาจะต้องจัดส่งรายงานผลการทดสอบเฉพาะแบบ หรือหนังสือรับรองผลการทดสอบเฉพาะแบบมาพร้อมกับการยื่นเอกสารทางเทคนิค” แทนการกำหนดระยะเวลาจัดส่งรายงานฯ ที่ได้ระบุไว้ในรายละเอียดสเปก

ทั้งนี้ ยกเว้นบางพัสดุอุปกรณ์ที่ กฟภ. กำหนดยอมรับให้ทำการทดสอบเฉพาะแบบภายหลังจากที่ทำสัญญากับ กฟภ. แล้ว โดยคู่สัญญาจะต้องจัดส่งรายงานผลการทดสอบฯ ดังกล่าว ก่อนการส่งของนั้น ให้ลงรายละเอียดไว้ตามเดิม

2. การกำหนดระยะเวลาในการจัดส่งตัวอย่าง (Sample) เพื่อประกอบการพิจารณาจัดหา

หากรายละเอียดสเปกกำหนดให้ผู้เสนอราคาจะต้องจัดส่งตัวอย่างพัสดุอุปกรณ์ (Sample) เพื่อประกอบการพิจารณาจัดหา “ให้ผู้เสนอราคาจะต้องจัดส่งตัวอย่างพัสดุอุปกรณ์ ภายใน 5 วันทำการ นับถัดจากวันเสนอราคา” แทนการกำหนดระยะเวลาจัดส่งตัวอย่างที่ได้ระบุไว้ในรายละเอียดสเปก



PROVINCIAL ELECTRICITY AUTHORITY

TECHNICAL SPECIFICATION DIVISION

คุณสมบัติของสถาบันทดสอบ สำหรับการทดสอบเฉพาะแบบ (Type or Design tests)

Specification No. -

Approved date : 17/07/2561

Rev. No.: -

Form No. -

Page 1 of 2

เอกสารเพิ่มเติมแนบท้ายรายละเอียดสเปค

(ADDENDUM)

เอกสารเพิ่มเติม (ADDENDUM) นี้ ให้ถือเป็นส่วนหนึ่งของรายละเอียดสเปคที่เอกสารฯ นี้ได้แนบอยู่ด้วย

คุณสมบัติของสถาบันทดสอบ สำหรับการทดสอบเฉพาะแบบ (Type or Design tests)

หากรายละเอียดสเปคกำหนดรายชื่อ หรือคุณสมบัติของสถาบันทดสอบสำหรับการทดสอบเฉพาะแบบ ให้ใช้รายละเอียดคุณสมบัติดังต่อไปนี้ แทนการกำหนดรายชื่อ หรือคุณสมบัติของสถาบันทดสอบฯ ที่ได้กำหนดไว้ในรายละเอียดสเปค

All items of the type or design tests shall be conducted or inspected by the acknowledged testing laboratories/institutes as following:

- (1) Laboratories/institutes which are members of the Short-circuit Testing Liaison (STL) or independent laboratories/institutes which are accredited according to TIS 17025 or ISO/IEC 17025 with the scope of accreditation covered the relevant test items, standards and equipment. The certification and scope of accreditation of the independent laboratories/institutes shall be submitted with the bid for consideration.
- (2) Thailand's national laboratories, institutes, universities and electric utilities, as follows:
 - National Metal and Materials Technology Center (MTEC)
 - Electrical and Electronic Products Testing Center (PTEC)
 - Thai Industrial Standards Institute (TISI)
 - Electrical and Electronics Institute (EEI)
 - Department of Science Service (DSS)
 - Testing Laboratory, Electrical Engineering Department, Faculty of Engineering, Chulalongkorn University
 - Electricity Generating Authority of Thailand (EGAT)
 - Metropolitan Electricity Authority (MEA)
 - Provincial Electricity Authority (PEA)
 - Other laboratories, institutes, universities or electric utilities approved by PEA

In case of the foreign manufacturers have experience of more than twenty (20) years in design, manufacture and sell such the proposed equipment for using in equal to or higher than system voltages of the proposed equipment, PEA will accept type or design test reports conducted by the manufacturer's laboratory or other independent laboratories without qualification mentioned in (1) or (2). Documents showing the manufacturer's experience such as reference list shall be submitted with the bid for consideration.



PROVINCIAL ELECTRICITY AUTHORITY

TECHNICAL SPECIFICATION DIVISION

คุณสมบัติของสถาบันทดสอบ สำหรับการทดสอบเฉพาะแบบ (Type or Design tests)

Specification No. -

Approved date : 17/07/2561

Rev. No.: -

Form No. -

Page 2 of 2

The bidders or manufacturers who prefer to carry out the type or design tests of the proposed equipment by the laboratories or by the manufacturer themselves without the qualification mentioned above, the detail of the test facilities of the laboratories or the manufacturer shall be submitted to PEA for approval before proceeding the tests and before the bid closing date. PEA reserves the right to send representatives to inspect and witness the tests with the cost of the bidders or manufacturers.

The type or design test reports done by the laboratories in Thailand or local manufacturers shall be valid within five (5) years counted from the issued date in the test report to the bid closing date.



การไฟฟ้าส่วนภูมิภาค
PROVINCIAL ELECTRICITY AUTHORITY

PROVINCIAL ELECTRICITY AUTHORITY

TECHNICAL SPECIFICATION DIVISION

การกำหนดการส่งรายงานผลการทดสอบเฉพาะแบบ (Type test report) เพื่อประกอบการพิจารณาจัดหา

Specification No.: - Approved date: 17/07/2561 Rev. No.: - Form No.: - Page 1 of 1

เอกสารเพิ่มเติมแนบท้ายรายละเอียดสเปค

(ADDENDUM)

เอกสารเพิ่มเติม (ADDENDUM) นี้ ให้ถือเป็นส่วนหนึ่งของรายละเอียดสเปคที่เอกสารฯ นี้ได้แนบอยู่ด้วย

การกำหนดการส่งรายงานผลการทดสอบเฉพาะแบบ (Type test report)

ผู้ยื่นข้อเสนอสามารถยื่นเอกสาร หรือหลักฐานอื่นเพื่อประกอบการพิจารณาจัดซื้อ จัดจ้าง หรือจ้างก่อสร้าง แทนการยื่นรายงานผลการทดสอบเฉพาะแบบ (Type test report) หรือหนังสือรับรองผลการทดสอบเฉพาะแบบ (Type test certificate) ได้ ดังนี้:

- (1) กรณีที่เป็นอุปกรณ์ที่การไฟฟ้าส่วนภูมิภาคสำนักงานใหญ่ โดยฝ่ายจัดหา หรือฝ่ายงานสถานีไฟฟ้า หรือฝ่ายงานระบบไฟฟ้า เคยรับไว้ใช้งานจากการจัดซื้อ จัดจ้าง หรืองานจ้างก่อสร้างแล้ว ผู้ยื่นข้อเสนอสามารถยื่นสำเนาหนังสือสั่งซื้อ/จ้าง (Purchase order) หรือสำเนาหนังสือสัญญาจ้างก่อสร้างพร้อมบัญชีแสดงปริมาณวัสดุ (Bill of Materials: BOQ) ที่ออกโดยการไฟฟ้าส่วนภูมิภาค แทนได้ หรือ
- (2) กรณีที่อุปกรณ์ที่เสนอได้รับการขึ้นทะเบียน และควบคุมคุณภาพผลิตภัณฑ์ (PEA Product Acceptance) แล้ว ผู้ยื่นข้อเสนอสามารถยื่นเอกสารรับรองการขึ้นทะเบียนฯ ที่ยังไม่หมดอายุในวันที่ยื่นเอกสาร แทนได้ หรือ
- (3) กรณีที่อุปกรณ์ที่เสนอราคาได้รับการขึ้นทะเบียนอุปกรณ์หลักในงานจ้างก่อสร้างสถานีไฟฟ้า (Product list) แล้ว ผู้ยื่นข้อเสนอสามารถยื่นเอกสารรับรองการขึ้นทะเบียนฯ ที่ยังไม่หมดอายุในวันที่ยื่นเอกสาร แทนได้

ทั้งนี้ เอกสาร หรือหลักฐานที่ระบุไว้ในข้อ (1) ข้อ (2) และข้อ (3) ดังกล่าวข้างต้น จะสามารถใช้แทนการยื่นรายงานผลการทดสอบเฉพาะแบบ (Type test report) หรือหนังสือรับรองผลการทดสอบเฉพาะแบบ (Type test certificate) ได้ ต้องเป็นเอกสาร หรือหลักฐานที่ตรวจสอบแล้วพบว่าเป็นของอุปกรณ์ที่เป็นผลิตภัณฑ์รุ่น และพิกัดเดียวกับอุปกรณ์ที่จัดซื้อ หรือจัดจ้าง หรือจ้างก่อสร้าง ในครั้งนี้



PROVINCIAL ELECTRICITY AUTHORITY

TECHNICAL SPECIFICATION DIVISION

INSULATORS

Specification No.: -

Approved date: 2/12/2563

Rev. No.: -

Form No. -

Page 1 of 1

เอกสารเพิ่มเติมแนบท้ายรายละเอียดสเปค (Addendum) ประกอบการจัดซื้อลู่ถ้วย

เอกสารเพิ่มเติมแนบท้ายรายละเอียดสเปคนี้ ใช้แนบกับสเปคอ้างอิงเลขที่ RINS-002/2561 และสเปคอ้างอิงเลขที่ RINS-005/2551 เพื่อประกอบการจัดหาลู่ถ้วย (Insulators)

“หากรายละเอียดสเปค หรือเอกสารเพิ่มเติมแนบท้ายรายละเอียดสเปค (Addendum) อื่นมีการกำหนดอายุของรายงานผลการทดสอบเฉพาะแบบ (Type and design test report) ไว้ ให้การกำหนดอายุของรายงานผลการทดสอบเฉพาะแบบดังกล่าว เริ่มมีผลบังคับใช้ตั้งแต่วันที่ 1 มกราคม 2566 เป็นต้นไป”



PROVINCIAL ELECTRICITY AUTHORITY

TECHNICAL SPECIFICATION DIVISION

INSULATORS

Specification No.: RINS-002/2561

Approved date: 21/05/2561

Rev. No.: 2

Form No. 01-1

Page 1 of 9

Invitation to Bid No. :

C Material, equipment, and specifications for INSULATORS

C1 General material and packing instructions

Additional to the general instructions, the following shall be observed :

1a Scope

These specifications cover insulators for overhead HV (up to 115 kV) and LV lines.

1b Standard

The insulators shall be manufactured and tested in accordance with the following standards:

Thai Industrial Standards (TIS)

TIS 227 - 2525 Spool-type porcelain insulators

TIS 279 - 2521 Pin-type porcelain insulators

TIS 280 - 2525 Strain-type porcelain insulators

TIS 354 - 2523 Suspension-type porcelain insulators

TIS 563 - 2528 Suspension-type toughened glass insulators

TIS 1077 - 2535 Line-post type porcelain insulators

TIS 1251 - 2537 Pin-post type porcelain insulators

American National Standards Institute (ANSI)

ANSI C29.1 - 1988 Test methods for electrical power insulators

ANSI C29.2A - 2013 Wet-process porcelain and toughened glass – distribution suspension type

ANSI C29.2B - 2013 Wet-process porcelain and toughened glass – transmission suspension type

ANSI C29.9 - 2017 Wet-process porcelain insulators – apparatus, post – type

International Electrotechnical Commission (IEC)

IEC 60383-1 -1993 Insulators for overhead lines with a nominal voltage above 1000 V – Part 1:
Ceramic or glass insulator units for a.c. systems – Definitions, test methods
and acceptance criteria

And all other relevant standards, unless otherwise specified in these specifications.

PEA will accept the design/type test reports in accordance with the later edition of the above standards.

PEA will also accept the design/type test report in accordance with the previous edition of the above standards, if there is no significant change in any test items or no additional test item(s) compared with the above standards. On the other hand, if there is significant change in any test items or there are any additional test items, the previous edition type test report with the additional test report(s) of the significant change test item(s) and/or additional test item(s) will be also accepted.



PROVINCIAL ELECTRICITY AUTHORITY

TECHNICAL SPECIFICATION DIVISION

INSULATORS

Specification No.: RINS-002/2561

Approved date: 21/05/2561

Rev. No.: 2

Form No. 01-1

Page 2 of 9

1c Principal requirement

1c.1 General

The porcelain insulators shall be brown glazed.

The pin hole threads of the pin type insulators shall be zinc thimble according to TIS .

The insulator shells of suspension insulator of porcelain type shall be made of highest grade, dense, homogeneous, wet-process, high strength alumina porcelain.

The surface shells of suspension insulator of porcelain type exposed after the assembly shall be relatively smooth and free of imperfections.

The porcelain head of the suspension insulator shall be cylindrical headed with sand surfaces; the "dove tail" shaped head shall not be accepted.

For the line-post insulator and pin-post insulator, the porcelain part shall be factory-fixed with stud, washer, nut, and lock nut.

1c.2 Marking

Each insulator shall be marked legibly and durably, as follows :

- (1) Manufacturer's name and/or Trade-mark.
- (2) Year of manufacture.
- (3) Only for suspension insulators :
 - Tension-proof test load in kN, identified by the word "TEST".
 - Combined mechanical and electrical strength in kN, identified by the symbol "M&E, except that of class 52-1.
- (4) Only for line-post insulator and pin-post insulator : Magnitude of the power arc current in kA and duration in second, identified by the word "POWARC".
- (5) PEA's trademark, as the figure shown.



- (6) Others according to manufacturer's design.

1c.3 Sample

The bidders have to supply two (2) samples of each item of the insulators within five (5) working days counted from bid closing date. The bidders who cannot supply the requested samples shall be rejected.

PEA reserves the right to test the samples according to PEA's testing procedure. In case of the failing test results, the bidders shall be rejected.

The samples shall not be returned.



PROVINCIAL ELECTRICITY AUTHORITY

TECHNICAL SPECIFICATION DIVISION

INSULATORS

Specification No.: RINS-002/2561

Approved date: 21/05/2561

Rev. No.: 2

Form No. 01-1

Page 3 of 9

1c.4 Tests and test reports

HV insulators and LV insulators shall be passed all item of design/type tests, quality conformance tests and routine tests in accordance with the relevant TIS or ANSI or IEC.

The design/type tests for suspension insulator, line-post insulator and pin-post insulator shall conform to as follows :

- (1) The proposed HV insulators shall have successfully passed the design/type test in accordance with the relevant standard.

For suspension insulator, thermal-mechanical load cycle test in accordance with the ANSI, or thermal-mechanical performance test in accordance with the IEC, shall be included.

- (2) The additional acceptance criteria for determining conformance with PEA's requirements for thermal-mechanical load cycle test (or thermal-mechanical performance test) and combined mechanical and electrical strength tests (or electromechanical and mechanical failing load tests) shall be as follows :

$$\frac{\bar{R} - R_s}{S} = Q_s \geq 3$$

Where :

Q_s = Criteria of judgement for acceptance

\bar{R} = Average value obtained from the test

R_s = Rated Mechanical and Electrical strength value of the insulator

S = Standard deviation from the test

Each value measured shall not be lower than the rated Mechanical and Electrical strength; electrical puncture shall not occur before reaching ultimate failure.

Sample size shall be of ten (10) units.

The insulators shall be passed the special tests as follows :

For line-post insulator and pin-post insulator : power arc test (see Appendix 1).

For suspension insulator : steep wave front impulse test and power arc test (see Appendix 2).

If Portland cement is used in the assembly of the insulators, it shall have an autoclave expansion limit of less than 0.12 percent when tested in accordance with ASTM C 151-84 or later edition, Test method for autoclave expansion of portland cement.



PROVINCIAL ELECTRICITY AUTHORITY

TECHNICAL SPECIFICATION DIVISION

INSULATORS

Specification No.: RINS-002/2561

Approved date: 21/05/2561

Rev. No.: 2

Form No. 01-1

Page 4 of 9

The design/type tests and the special tests shall be conducted or inspected by the acknowledged testing laboratories/institutes as following:

- (1) Independent laboratories/institutes which are members of the Short-circuit Testing Liaison (STL) or independent laboratories/institutes which are accredited according to TIS 17025 or ISO/IEC 17025 with the scope of accreditation covered the relevant test items, standards and equipment. The certification and scope of accreditation of the independent laboratories/institutes shall be submitted with the bid for consideration.
- (2) Thailand's national laboratories, institutes, universities and electric utilities, as follows:
 - National Metal and Materials Technology Center (MTEC)
 - Electrical and Electronic Products Testing Center (PTEC)
 - Thai Industrial Standards Institute (TISI)
 - Electrical and Electronics Institute (EEI)
 - Department of Science Service (DSS)
 - Testing Laboratory, Electrical Engineering Department, Faculty of Engineering, Chulalongkorn University
 - Electricity Generating Authority of Thailand (EGAT)
 - Metropolitan Electricity Authority (MEA)
 - Provincial Electricity Authority (PEA)
 - Other laboratories, institutes, universities or electric utilities approved by PEA

The bidders or manufacturers who prefer to carry out the insulators with the laboratories or by the manufacturer themselves without the qualification mentioned above, the detail of the test facilities of the laboratories or the manufacturer shall be submitted to PEA for approval before proceeding the tests and before the bid closing date. PEA reserves the right to send representatives to inspect and witness the tests with the cost of the bidders or manufacturers.

The design/type test report done by the laboratories in Thailand or local manufacturers shall be valid within five (5) years counted from the issued date in the test report to the bid closing date.

The bidders have to submit the design/type test reports and/or design/type test certificates of the insulators with the bid.



PROVINCIAL ELECTRICITY AUTHORITY

TECHNICAL SPECIFICATION DIVISION

INSULATORS

Specification No.: RINS-002/2561

Approved date: 21/05/2561

Rev. No.: 2

Form No. 01-1

Page 5 of 9

PEA will also accept other documents instead of the design/type test reports and design/type test certificates in the following conditions:

- (1) In case the proposed insulators has been supplied to PEA and get the order from PEA's Procurement Department (from PEA's head office), the Purchase Order (PO) can be submitted, or
- (2) In case the proposed insulators has been registered for PEA Product Acceptance, the not-expired registration certificate counted to the bid closing date can be submitted, or
- (3) In case the proposed insulators has been registered for Product lists for substation turnkey project, the not-expired registration certificate counted to the bid closing date can be submitted instead

However the document in case (1) and (2) shall be proved that the insulators specified in the PO or registration certificate shall be the same product, type/model and all ratings as the proposed insulators for this bid and shall be used the same PEA's specification number. In case (3), the insulators specified in the registration certificate shall be the same product, type/model and all ratings as the proposed insulators for this bid.

The cost of all tests and reports shall be borne by the Bidders/Contractor.



PROVINCIAL ELECTRICITY AUTHORITY

TECHNICAL SPECIFICATION DIVISION

INSULATORS

Specification No.: RINS-002/2561

Approved date: 21/05/2561

Rev. No.: 2

Form No. 01-1

Page 6 of 9

1d Packing

Each item shall be packed in export packages in sets or pieces. The packages shall be right-square or right-rectangular forms.

The packages of same item shall be assembled into a bundle and fastened with steel bands over a pallet to make it movable by a forklift truck. The pallet shall be designed in such a manner that the truck's forks can be inserted at any side of the pallet. The steel strapped bundle shall be strong enough to withstand rough handling during transit and inland transportation and of 400 - 900 kg .

If the package is made of rubber wood (Yang-para or Hevea brasiliensis) the wooden parts shall be treated with wood preservative.

The number of sets or pieces per package and the number of packages per pallet for each item of insulators shall be as follows :

Type	PEA Material No.	Number of sets or pieces per package	Number of packages per pallet
Line – post type, class 57-2	1030010002	2	36
Line – post type, class 57-4	1030010004	1	30
Pin – post type, class 56/57-2	1030010101	2	30
Pin – post type, class 56/57-4	1030010102	1	30
Station post type TR No. 208	1030010201	2	30
Station post type TR No. 210	1030010202	2	30
Station post type TR No. 202	1030010200	3	30
Station post type TR No. 286	1030010203	1	6
Suspension type (porcelain or toughened glass), class 52-1	1030020000	6	36
Suspension type (porcelain or toughened glass), class 52-4	1030020002	6	20
Suspension type (porcelain or toughened glass), class 52-3	1030020001	6	20
Suspension type (porcelain or toughened glass), class 52-8	1030020003	6	16
Pin type, class 56-2	1030000001	4	20
Pin type, class 56-3	1030000002	4	20
Pin, fog type	1030000003	2	20
Spool type, class 53-2	1030030000	100	12
Strain type, class 54-1	1030030100	100	12
Strain type, class 54-4	1030030103	25	12



PROVINCIAL ELECTRICITY AUTHORITY

TECHNICAL SPECIFICATION DIVISION

INSULATORS

Specification No.: RINS-002/2561

Approved date: 21/05/2561

Rev. No.: 2

Form No. 01-1

Page 7 of 9

C2 Material and packing data of the insulators

The following guarantee performances and details shall be submitted with the bid:

2a For each item offered, the following details shall be submitted :

Catalogue number.

Only for HV insulators, the test certificates of design/type test and of the relevant quality conformance tests with inspector's signature.

Specifications of materials used for the component parts.

- P** Pin type
 S Suspension type
 T Spool type
 N Strain type
 L Line/pin-post type

Design data and guarantee of the proposed insulators

Type of insulators	<input type="radio"/> P	<input type="radio"/> S	<input type="radio"/> T	<input type="radio"/> N	<input type="radio"/> L
Characteristics					
ANSI Class or TIS Type or					
<u>Dimensions</u>					
Leakage distance	mm	mm	-	mm	mm
Protected leakage distance	-	-	-	-	mm
Dry-arcing distance	mm	-	-	-	mm
Minimum pin height	mm	-	-	-	-
<u>Mechanical values</u>					
Cantilever strength	kN	-	-	-	kN
Combined mechanical and electrical strength	-	kN	-	-	-
Electromechanical failing load	-	kN	-	-	-
Mechanical failing load	-	kN	-	-	-
Mechanical impact strength	-	cm-N	-	-	-
Tension proof	-	kN	-	-	-
Time load	-	kN	-	-	-
Transverse strength	-	-	kN	-	-
Tensile strength	-	-	-	kN	-
<u>Electrical values</u>					
Low-frequency dry flashover	kV	kV	kV	kV	kV
Low-frequency wet flashover	kV	kV	kV	kV	kV
Critical-impulse flashover, positive	kV	kV	-	-	kV
Critical-impulse flashover, negative	kV	kV	-	-	kV
Low-frequency puncture	kV	kV	-	-	-
<u>Radio-influence-voltage data</u>					
Low-frequency test voltage, r.m.s. to ground	kV	kV	-	-	kV
Maximum riv at 1,000 kHz	µV	µV	-	-	µV
<u>Weight of one insulator</u>	kg	kg	kg	kg	kg
<u>Colour</u>



PROVINCIAL ELECTRICITY AUTHORITY

TECHNICAL SPECIFICATION DIVISION

INSULATORS

Specification No.: RINS-002/2561

Approved date: 21/05/2561

Rev. No.: 2

Form No. 01-1

Page 8 of 9

2b For each item offered, detail drawing(s) with dimensions and tolerances in mm, showing glazed and unglazed surface and the symbol identifying the manufacturer shall be submitted.

2c Packing details

Packing method (shown by drawing(s), describe packing materials, details of wood treatment for rubber wood package)

Number of sets or pieces in each package

Dimensions (length x width x height) of each package in cm

Volume of each package in m³

Gross weight of each package in kg

Net weight of each package in kg

Number of packages

If several packages are assembled into a bundle, further details are required

Number of packages in each bundle

Dimensions (length x width x height) of each bundle in cm

Volume of each bundle in m³

Gross weight of each bundle in kg

Net weight of each bundle in kg

Number of bundles

Note : Conditions for documentation and consideration

The Contractor has to supply report of design/type tests, special tests, quality conformance tests and routine tests of the insulators in **English and/or Thai**, before shipment/delivery, to the following address:

Technical Specification Division
Engineering Department
Provincial Electricity Authority
200 Ngam Wong Wan Road, Chatuchak
Bangkok 10900
Thailand



PROVINCIAL ELECTRICITY AUTHORITY

TECHNICAL SPECIFICATION DIVISION

INSULATORS

Specification No.: RINS-002/2561

Approved date: 21/05/2561

Rev. No.: 2

Form No. 01-1

Page 9 of 9

Critical documents of the proposed insulators shall be submitted with the bid as follows:

Item	Description of document	Confirmation	Reference (Page No./folder)
1	List of routine tests	<input type="checkbox"/> Yes <input type="checkbox"/> No	
2	Design/Type test report and/or test certificate or	<input type="checkbox"/> Yes <input type="checkbox"/> No	
	The copy of previous Purchase order (if any) or	<input type="checkbox"/> Yes <input type="checkbox"/> No	
	PEA Product Acceptance certificate (if any) or	<input type="checkbox"/> Yes <input type="checkbox"/> No	
	Product lists certificate (if any)	<input type="checkbox"/> Yes <input type="checkbox"/> No	
3	Design data and guarantee of the proposed insulators	<input type="checkbox"/> Yes <input type="checkbox"/> No	
4	Detailed drawing(s) with dimensions and tolerances in mm	<input type="checkbox"/> Yes <input type="checkbox"/> No	
5	Packing details	<input type="checkbox"/> Yes <input type="checkbox"/> No	

Note: The bidders who do not submit all critical documents mentioned in the above table with the bid will be rejected.



PROVINCIAL ELECTRICITY AUTHORITY

TECHNICAL SPECIFICATION DIVISION

Specification No.: RINS-002/2561 : INSULATORS

Page 1 of 4

C3 Schedule of detailed requirement

Invitation to Bid No.:

Item	PEA Material No.	Quantity	Description
1	1030010002	3,048 set (s)	Insulator, line-post type, according to TIS 1077, Type 57-2; complete with 19 x 178 mm stud furnishing with square washer, nut, and lock nut.
2	1030010004	set (s)	Insulator, line-post type, according to TIS 1077, Type 57-4; complete with 19 x 178 mm stud furnishing with square washer, nut, and lock nut.
3	1030010101	set (s)	Insulator, pin-post type, according to TIS 1251, Type 56/57-2; complete with M20 x 178 mm stud furnishing with square washer, nut, and lock nut.
4	1030010102	set (s)	Insulator, pin-post type, according to TIS 1251, Type 56/57-4; complete with M20 x 178 mm stud furnishing with square washer, nut, and lock nut.
5	1030010201	set (s)	Insulator, station post type, for 22 kV system, according to ANSI C29.9 Technical Reference No. 208 .
6	1030010202	set (s)	Insulator, station post type, for 33 kV system, according to ANSI C29.9 Technical Reference No. 210 .
7	1030010200	601 set (s)	Insulator, station post type, for 115 kV system according to ANSI C29.9 Technical Reference No. 202 .
8	1030010203	set (s)	Insulator, station post type, for 115 kV system according to ANSI C29.9 Technical Reference No. 286 .
9	1030020000	5,502 set (s)	Insulator, suspension type, according to TIS 354 (porcelain) Type A (Class 52-1), used in string for 22 kV system.
10	1030020002	240 set (s)	Insulator, suspension type, according to TIS 354 (porcelain) Type D (Class 52-4), used in string for 22 kV and 33 kV systems.
11	1030020001	set (s)	Insulator, suspension type, according to TIS 354 (porcelain) Type C (Class 52-3), used in string for 115 kV system.
	III		



PROVINCIAL ELECTRICITY AUTHORITY

TECHNICAL SPECIFICATION DIVISION

Specification No.: RINS-002/2561 : INSULATORS

Page 2 of 4

C3 Schedule of detailed requirement

Invitation to Bid No.:

Item	PEA Material No.	Quantity	Description
12	1030020003	set (s)	Insulator, suspension type, according to TIS 354 (porcelain) Type E (Class 52-8), used in string for 115 kV system.
13	1030020000	set (s)	Insulator, suspension type, according to TIS 563 (toughened glass) Class 52-1, used in string for 22 kV system.
14	1030020002	set (s)	Insulator, suspension type, according to TIS 563 (toughened glass) Class 52-4, used in string for 22 kV and 33 kV system.
15	1030020001	set (s)	Insulator, suspension type, according to TIS 563 (toughened glass) Class 52-3, used in string for 115 kV system.
16	1030020003	set (s)	Insulator, suspension type, according to TIS 563 (toughened glass) Class 52-8, used in string for 115 kV system.
17	1030020000	set (s)	Insulator, suspension type, according to TIS 354 (porcelain) Type A (Class 52-1) or according to TIS 563 (toughened glass) Class 52-1, used in string for 22 kV system.
18	1030020002	set (s)	Insulator, suspension type, according to TIS 354 (porcelain) Type D (Class 52-4) or according to TIS 563 (toughened glass) Class 52-4, used in string for 22 kV system and 33 kV system.
19	1030020001	set (s)	Insulator, suspension type, according to TIS 354 (porcelain) Type C (Class 52-3) or according to TIS 563 (toughened glass) Class 52-3, used in string for 115 kV system.
20	1030020003	set (s)	Insulator, suspension type, according to TIS 354 (porcelain) Type E (Class 52-8) or according to TIS 563 (toughened glass) Class 52-8, used in string for 115 kV system.
21	1030000001	set (s)	Insulator, pin type, one-piece porcelain, three (3) porcelain shells, radio freed, for 22 kV system, according to TIS 279 Type B (Class 56-2) .
	III		



PROVINCIAL ELECTRICITY AUTHORITY

TECHNICAL SPECIFICATION DIVISION

Specification No.: RINS-002/2561 : INSULATORS

Page 3 of 4

C3 Schedule of detailed requirement

Invitation to Bid No.:

Item	PEA Material No.	Quantity	Description
22	1030000002	set (s)	Insulator, pin type, radio freed, for 33 kV system, according to TIS 279 Type C (Class 56-3).
23	1030000003	set (s)	Insulator, pin, fog type, radio freed, ANSI 1 3/8" diameter pin hole, similar to NGK Cat. No. HRAA-025571 C.
24	1030030000	13,440set (s)	Insulator, spool type, according to TIS 227 Type B (Class 53-2).
25	1030030100	96 set (s)	Insulator, strain type, according to TIS 280 Type A (Class 54-1).
26	1030030103	450set (s)	Insulator, strain type, according to TIS 280 Type D (Class 54-4).
			<p><u>Note :</u></p> <p>1. Enclosed characteristics of insulators, detail of special tests and detail of additional routine tests as follows :</p> <p>1.1 <u>For line post insulators</u></p> <p>1.1.1 Characteristics of insulators according to TIS 1077, two (2) pages.</p> <p>1.1.2 Appendix 1, details of power arc tests, two (2) pages.</p> <p>1.2 <u>For Pin Post Insulators</u></p> <p>1.2.1 Characteristics of insulators according to TIS 1251, one (1) page.</p> <p>1.2.2 Appendix 1, details of power arc tests, two (2) pages</p> <p>1.3 <u>For Suspension Insulators</u></p> <p>1.3.1 Characteristics of insulators according to TIS 354, TIS 563, four (4) pages.</p> <p>1.3.2 Appendix 2, details of special tests, one (1) page.</p> <p>1.3.3 Appendix 3, details of additional routine tests, one (1) page.</p> <p>1.4 <u>For Pin Type Insulators</u></p> <p>Characteristics of insulators according to TIS 279, two (2) pages.</p> <p>1.5 <u>For Fog Type Insulator</u></p> <p>Characteristics of insulators similar to NGK Cat. No. HRAA-025571 C, one (1) page.</p>
	III		



PROVINCIAL ELECTRICITY AUTHORITY

TECHNICAL SPECIFICATION DIVISION

Specification No.: RINS-002/2561 : INSULATORS

Page 4 of 4

C3 Schedule of detailed requirement

Invitation to Bid No.:

Item	PEA Material No.	Quantity	Description
	III		<p>1.6 <u>For Spool Type Insulator</u> Characteristics of insulator according to TIS 227, one (1) page.</p> <p>1.7 <u>For Strain Type Insulator</u> Characteristics of insulator according to TIS 280, one (1) page.</p> <p>2. PEA reserves the right to have the test(s) on the samples which shall be performed by a third party, in Bangkok; and the costs of all test(s) and reports shall be borne by the bidders.</p>



PROVINCIAL ELECTRICITY AUTHORITY
TECHNICAL SPECIFICATION DIVISION

Specification No.: RINS-002/2561 : INSULATORS

Page 1 of 5

C4 Price schedule		Manufacturer :		
Invitation to Bid No.:		Country of origin :	Unit Cost (See details & conditions & attached)	Total Cost (See details & conditions & attached)
Item	PEA Material No.	Description	Quantity	
1	1030010002	Insulator, line-post type, according to TIS 1077, Type 57-2; complete with 19 x 178 mm stud furnishing with square washer, nut, and lock nut.	3,048 set (s)	
2	1030010004	Insulator, line-post type, according to TIS 1077, Type 57-4; complete with 19 x 178 mm stud furnishing with square washer, nut, and lock nut.	set (s)	
3	1030010101	Insulator, pin-post type, according to TIS 1251, Type 56/57-2; complete with M20 x 178 mm stud furnishing with square washer, nut, and lock nut.	set (s)	
4	1030010102	Insulator, pin-post type, according to TIS 1251, Type 56/57-4; complete with M20 x 178 mm stud furnishing with square washer, nut, and lock nut.	set (s)	
5	1030010201	Insulator, station post type, for 22 kV system, according to ANSI Technical Reference No. 208 .	set (s)	
6	1030010202	Insulator, station post type, for 33 kV system, according to ANSI Technical Reference No. 210 .	set (s)	
	III			



**PROVINCIAL ELECTRICITY AUTHORITY
TECHNICAL SPECIFICATION DIVISION**

Specification No.: RINS-002/2561 : INSULATORS

Page 2 of 5

C4 Price schedule		Manufacturer :			Unit Cost (See details & conditions & attached)	Total Cost (See details & conditions & attached)
Invitation to Bid No.:		Country of origin :	Quantity	Trade-mark :		
Item	PEA Material No.	Catalogue No.	Description			
7	1030010200		Insulator, station post type, for 115 kV system according to ANSI Technical Reference No. 202 .	601 set (s)		
8	1030010203		Insulator, station post type, for 115 kV system according to ANSI Technical Reference No. 286 .	set (s)		
9	1030020000		Insulator, suspension type, according to TIS 354 (porcelain) Type A (Class 52-1), used in string for 22 kV system.	5,502 set (s)		
10	1030020002		Insulator, suspension type, according to TIS 354 (porcelain) Type D (Class 52-4), used in string for 22 kV and 33 kV systems.	240 set (s)		
11	1030020001		Insulator, suspension type, according to TIS 354 (porcelain) Type C (Class 52-3), used in string for 115 kV system.	set (s)		
12	1030020003		Insulator, suspension type, according to TIS 354 (porcelain) Type E (Class 52-8), used in string for 115 kV system.	set (s)		
	III					



PROVINCIAL ELECTRICITY AUTHORITY
TECHNICAL SPECIFICATION DIVISION

Specification No.: RINS-002/2561 : INSULATORS

Page 3 of 5

C4 Price schedule		Manufacturer :		
Invitation to Bid No.:		Country of origin :	Unit Cost (See details & conditions attached)	Total Cost (See details & conditions attached)
Item	PEA Material No.	Description	Quantity	
13	1030020000	Insulator, suspension type, according to TIS 563 (toughened glass) Class 52-1, used in string for 22 kV system.	set (s)	
14	1030020002	Insulator, suspension type, according to TIS 563 (toughened glass) Class 52-4, used in string for 22 kV and 33 kV system.	set (s)	
15	1030020001	Insulator, suspension type, according to TIS 563 (toughened glass) Class 52-3, used in string for 115 kV system.	set (s)	
16	1030020003	Insulator, suspension type, according to TIS 563 (toughened glass) Class 52-8, used in string for 115 kV system.	set (s)	
17	1030020000	Insulator, suspension type, according to TIS 354 (porcelain) Type A (Class 52-1) or according to TIS 563 (toughened glass) Class 52-1, used in string for 22 kV system.	set (s)	
	III			



PROVINCIAL ELECTRICITY AUTHORITY
TECHNICAL SPECIFICATION DIVISION

Specification No.: RINS-002/2561 : INSULATORS

Page 4 of 5

C4 Price schedule		Manufacturer :		
Invitation to Bid No.:		Country of origin :	Unit Cost (See details & conditions attached)	Total Cost (See details & conditions attached)
Item	PEA Material No.	Description	Quantity	
18	1030020002	Insulator, suspension type, according to TIS 354 (porcelain) Type D (Class 52-4) or according to TIS 563 (toughened glass) Class 52-4, used in string for 22 kV system and 33 kV system.	set (s)	
19	1030020001	Insulator, suspension type, according to TIS 354 (porcelain) Type C (Class 52-3) or according to TIS 563 (toughened glass) Class 52-3, used in string for 115 kV system.	set (s)	
20	1030020003	Insulator, suspension type, according to TIS 354 (porcelain) Type E (Class 52-8) or according to TIS 563 (toughened glass) Class 52-8, used in string for 115 kV system.	set (s)	
21	1030000001	Insulator, pin type, one-piece porcelain, three (3) porcelain shells, radio freed, for 22 kV system, according to TIS 279 Type B (Class 56-2) .	set (s)	
22	1030000002	Insulator, pin type, radio freed, for 33 kV system, according to TIS 279 Type C (Class 56-3).	set (s)	
	III			



**PROVINCIAL ELECTRICITY AUTHORITY
TECHNICAL SPECIFICATION DIVISION**

Specification No.: RINS-002/2561 : INSULATORS

Page 5 of 5

C4 Price schedule

Invitation to Bid No.:

		Manufacturer :				
		Country of origin :				
		Trade-mark :				
Item	PEA Material No.	Catalogue No.	Description	Quantity	Unit Cost (See details & conditions attached)	Total Cost (See details & conditions attached)
23	1030000003		Insulator, pin, fog type, radio freed, ANSI 1 3/8" diameter pin hole, similar to NGK Cat. No. HRAA-025571 C.	set (s)		
24	1030030000		Insulator, spool type, according to TIS 227 Type B (Class 53-2).	13,440 set (s)		
25	1030030100		Insulator, strain type, according to TIS 280 Type A (Class 54-1).	96 set (s)		
26	1030030103		Insulator, strain type, according to TIS 280 Type D (Class 54-4).	450 set (s)		
	III					



Appendix 1

Power arc tests for line post/pin post type insulator

1. Test arrangement

The test arrangement shall be as shown in Drawing No. SA2-015/35042.

The power arc test shall be carried out in three-phase with three specimens simultaneously.

2. Power supply

The power supply shall be adequate to maintain the specified arc current for the specified duration. The arc current shall be practically sinusoidal and constant, and shall not deviate from the specified value by more than 10% during the test.

For long arc durations (greater than 20 cycles), the variation of the arc current may be greater than 10%, in this case, the arc current may be evaluated by its average peak value during the test duration.

The supply frequency shall be the rated frequency of 50 Hz or 60 Hz.

3. Arc initiation

The arc shall be initiated by means of a fuse wire of suitable diameter attached to the insulator as shown in detail "A" in Drawing No. SA2-015/35042.

4. Characteristics of the power arcs

The number, current, and duration of the power arcs to be applied to each set shall be as shown in the table below:

Type of Insulator		57-2 and 56/57-2		57-4 and 56/57-4	
Number		1	1	1	1
Minimum test current, r.m.s.	kA	10	3	10	3
Minimum duration	sec	0.40	0.65	0.40	0.79

5. Evaluation of the results

The insulators shall be considered to have passed the tests if there is no partial shed breakage on any insulators as the result of the power arc test.

การประกอบเลขที่
ASSEMBLY NO.

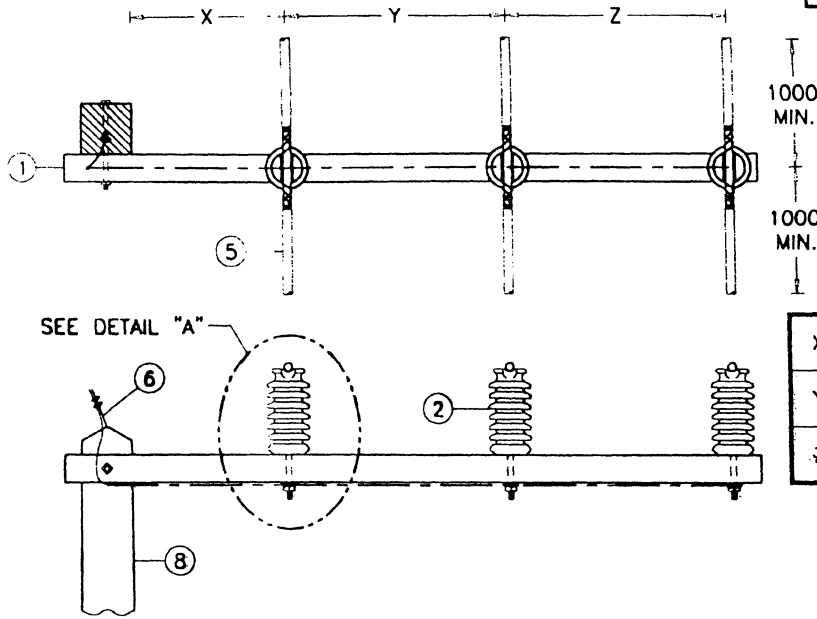

	57-2 and 56/57-2	57-4 and 56/57-4
X	MIN. 600	MIN. 750
Y	MIN. 800	MIN. 900
Z	MIN. 750	MIN. 850

SEE DETAIL "A"

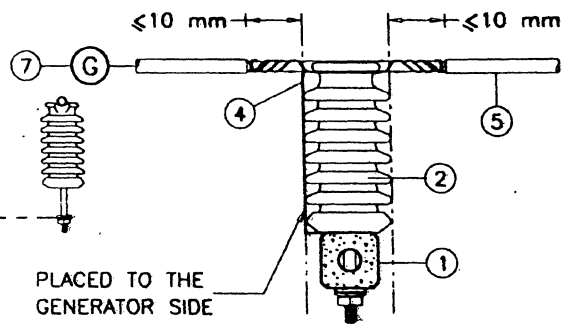
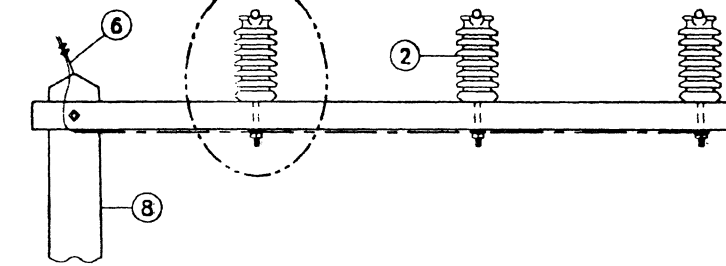

PLACED TO THE GENERATOR SIDE

FUSE WIRE ATTACHMENT

DETAIL "A"

EARTHING DIAGRAM

NOTES

- ① CONCRETE CROSSARM, THE CROSSARM CAN BE REPLACED BY A STEEL CHANNEL.
- ② INSULATOR.
- ③ STEEL WIRE, SOLID, DIAMETER OF 4 mm, IF ANY.
- ④ FUSE WIRE, PLACED TO THE GENERATOR SIDE.
- ⑤ COVERED CONDUCTOR.
- ⑥ STEEL STRANDED WIRE, DIAMETER OF 6.3 mm (BURIED IN CONCRETE POLE), IF ANY.
- ⑦ SHORT-CIRCUIT GENERATOR.
- ⑧ CONCRETE POLE, THE POLE CAN BE REPLACED BY A STEEL POLE, IF ANY.

กองวิศวกรรมไฟฟ้าและเครื่องกล
ฝ่ายวิศวกรรม

ผู้เขียน *Suphat Sanying*
ผู้สำรวจ.....
วิศวกร.....
หัวหน้าแผนก.....
ผู้อำนวยการกอง.....
ผู้อำนวยการฝ่าย.....

รองผู้อำนวยการเทคนิคและบริการ

การไฟฟ้าส่วนภูมิภาค

ผู้ว่าการ.....

POWER ARC TEST ARRANGMENT
FOR INSULATORS, FOR OVERHEAD LINES

ใช้แทนแบบ.....
ถูกแทนโดยแบบ.....
เขียนเสร็จวันที่.....
แก้ไขวันที่ 13. ต.ค. 2541
มีตีพิมพ์.....
มาตรฐาน..... 1 : 25.....
แบบเลขที่ SA2-015/35042
แผ่นที่ 1 ของจำนวน 1 แผ่น

PSD



Appendix 2

Special tests for suspension insulators

(class 52-1, 52-4, 52-3 and 52-8)

The special tests are as follows :

1. Steep wave front impulse test

The test shall be performed on ten (10) units of insulator selected at random.

The insulator shall be subject to ten (10) successive positive and negative impulse flashovers with a wave having an effective rate of rise of 2,500 kV/ μ s. The insulators shall be tested singly.

Each unit shall then be verified to be electrically intact by applying low-frequency voltage, dry or wet.

In case of wet test, the rated wet low-frequency withstand voltage shall be applied to each unit and no electrical puncture shall occur.

In case of dry test, the five (5) flashovers of the low-frequency dry flashover test in accordance with the ANSI C29.1 shall be applied and shall have a flashover value of not less than 95% of the rated value.

Failure of any one (1) unit either in the front-of-wave test or subsequent low frequency withstand voltage test shall cause for testing another twenty (20) units.

Failure of more than one (1) unit from total so tested shall constitute failure of this insulator design and will not meet requirements of these specifications.

2. Power arc test

Nine (9) insulator units of each type, in 3-unit strings, mounted vertically without arcing horns or conductors, shall be subject to power arcs of 12 kA r.m.s., symmetrical for 0.1 seconds of 6 kA r.m.s., symmetrical for 0.2 seconds.

The insulator string shall withstand the power arc without shell breakage. Failure of any one (1) string in the test shall be caused for testing another three (3) strings of the same type.

Failure of more than one (1) string from the total so tested shall constitute failure of this insulator design and will not meet requirements of these specifications.



Appendix 3

Additional routine tests for porcelain suspension insulators

(class 52-1, 52-4, 52-3 and 52-8)

The additional routine tests are as follows :

1. Hydraulic inner pressure test

The test shall be performed by injecting water into porcelain head portion for at least 2.5 second. The water pressure shall be as follows :

Suspension insulator Class	Minimum water pressure Kg/cm ²
52-1	80
52-4	140
52-3	140
52-8	180

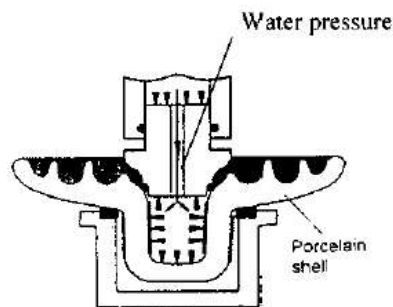

Hydraulic inner pressure test

2. High – frequency test follow by low – frequency test

Notwithstanding those specified in ANSI C29.2, routine flashover test of suspension insulator shall be performed by applied high-frequency test 100 – 500 kHz for at least 3 seconds follow by low – frequency test for at least 3 minutes.

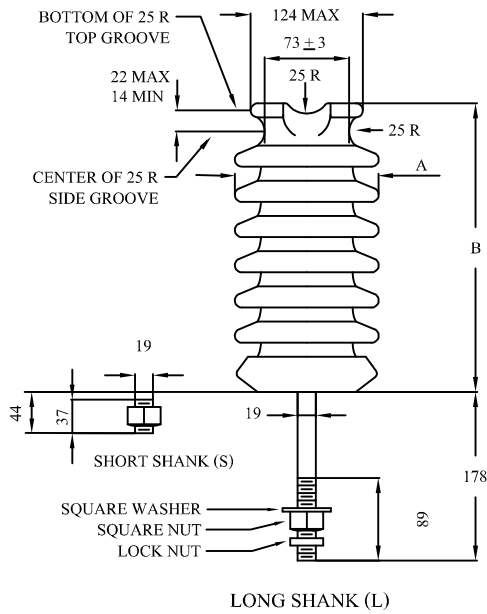

Note

1. Dimensions not specifying tolerances are only references.
2. See Fig 6 in TIS 1077, for base threading.
3. All dimensions are in mm.
4. Top-wire groove shall seat a 50 mm diameter mandrel.
5. Side-wire groove shall seat a 50 mm diameter mandrel.

57-2

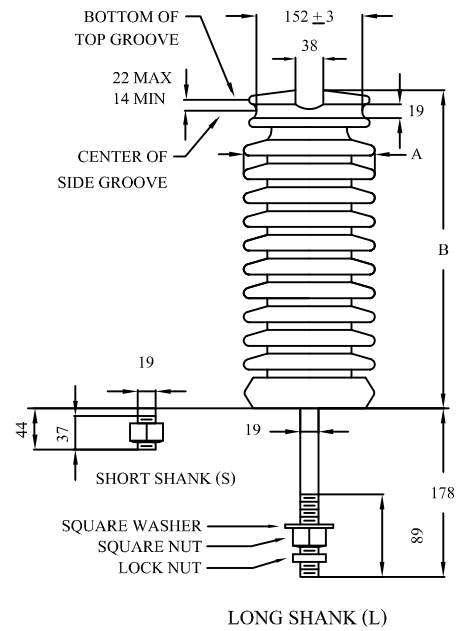

Note

1. Dimensions not specifying tolerances are only references.
2. See Fig 6 in TIS 1077, for base threading.
3. All dimensions are in mm.
4. Top-wire groove shall seat a 37 mm diameter mandrel.

57-4

TIS 1077 LINE-POST INSULATOR			57-2	57-4
DIMENSIONS	Leakage distance, minimum	mm	559	1,015
	Protected leakage distance, minimum	mm	224	406
	Dry-arcing distance, minimum	mm	241	368
	A	mm	152	178
	B	mm	305	432
MECHANICAL VALUES	Cantilever strength	kN	12.5	12.5
	Cantilever proof load	kN	5	5
ELECTRICAL VALUES	Low-frequency dry flashover	kV	110	150
	Low-frequency wet flashover	kV	85	125
	Critical-impulse flashover, positive	kV	180	255
	Critical-impulse flashover, negative	kV	205	340
RADIO-INFLUENCE VOLTAGE DATA	Low-frequency test voltage, rms to ground	kV	22	44
	Maximum RIV at 1,000 kHz, Radio freed	μV	100	200
COLOUR OF INSULATOR		Preferably	BROWN	

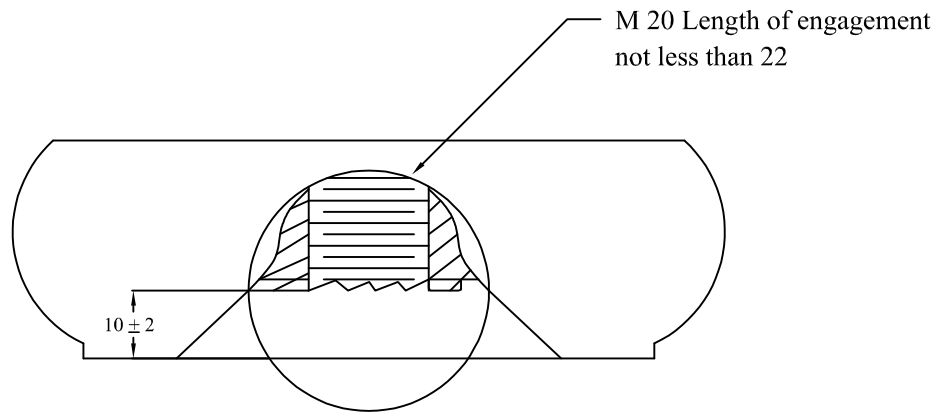

All dimensions are in mm

Fig. 6 in TIS 1077

Base Recess and Thread Dimensions

FOR LINE - POST INSULATOR ONLY

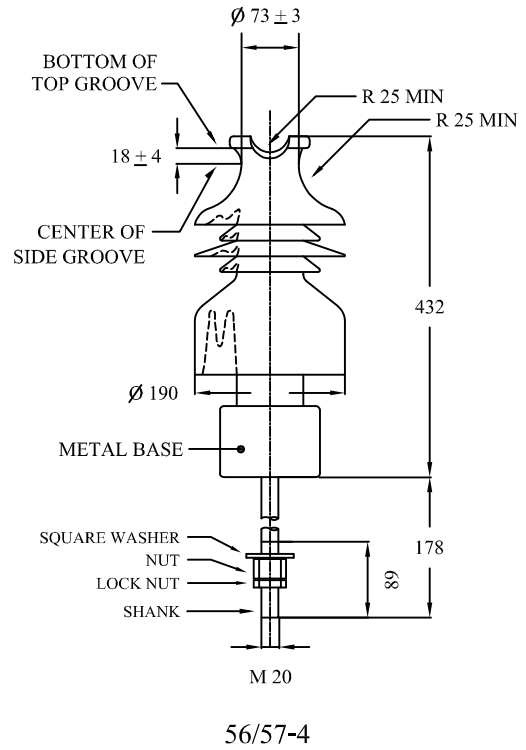
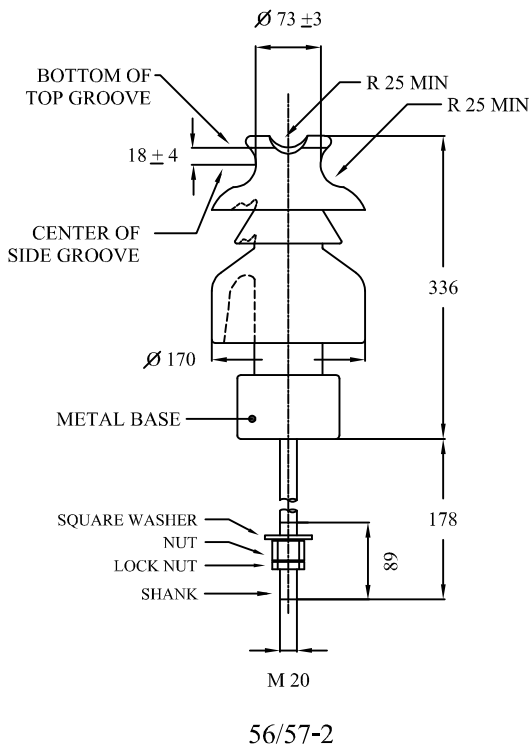

Note

1. Dimensions not specifying tolerances are only references.
2. All dimensions are in mm.
3. Top-wire groove shall seat a 50 mm diameter mandrel.
4. Side-wire groove shall seat a 50 mm diameter mandrel.

TIS 1251 PIN-POST INSULATOR		56/57-2	56/57-4	
DIMENSIONS	Leakage distance, minimum	mm	534	953
	Protected leakage distance, minimum	mm	267	483
MECHANICAL VALUES	Cantilever strength	kN	12.5	12.5
	Cantilever proof load	kN	5	5
ELECTRICAL VALUES	Low-frequency dry flashover	kV	110	140
	Low-frequency wet flashover	kV	80	95
	Critical-impulse flashover, positive	kV	180	255
	Critical-impulse flashover, negative	kV	205	300
RADIO-INFLUENCE VOLTAGE DATA	Low-frequency test voltage, rms to ground	kV	22	44
	Maximum RIV at 1,000 kHz, Radio freed	µV	100	200
COLOUR OF INSULATOR		Preferably	BROWN	

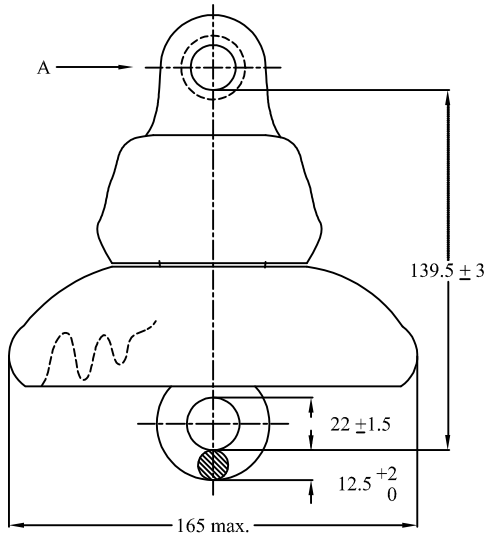

Class 52-1

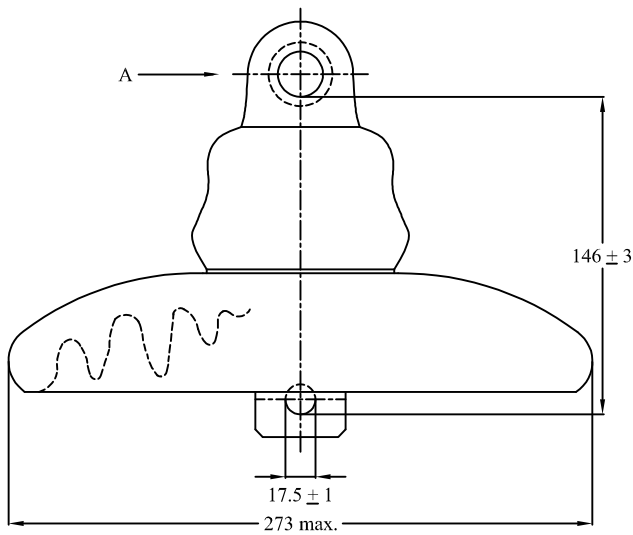
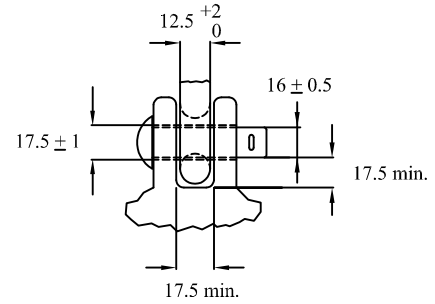

Class 52-4

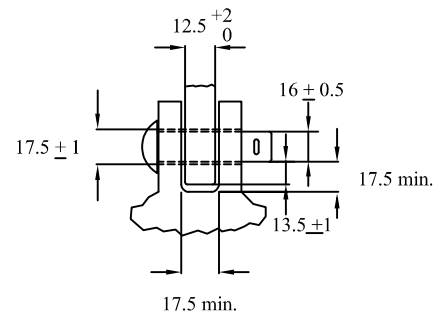

All dimensions are in mm

TIS 354 SUSPENSION-TYPE PORCELAIN INSULATOR		Type A Class 52-1	Type D Class 52-4	
MINIMUM DIMENSIONS	Leakage distance	mm	178	292
MECHANICAL VALUES	Combined mechanical and electrical strength	mm	44.48	66.72
	Mechanical impact strength	cm-N	507.37	621.34
	Tension proof	kN	22.24	33.36
	Time load	kN	26.69	44.48
ELECTRICAL VALUES	Low-frequency dry flashover	kV	60	80
	Low-frequency wet flashover	kV	30	50
	Critical-impulse flashover, positive	kV	100	125
	Critical-impulse flashover, negative	kV	100	130
	Low-frequency puncture	kV	80	110
RADIO-INFLUENCE VOLTAGE DATA	Low-frequency test voltage, rms to ground	kV	7.5	10
	Maximum RIV at 1,000 kHz	μV	50	50
COLOUR OF INSULATOR		BROWN		

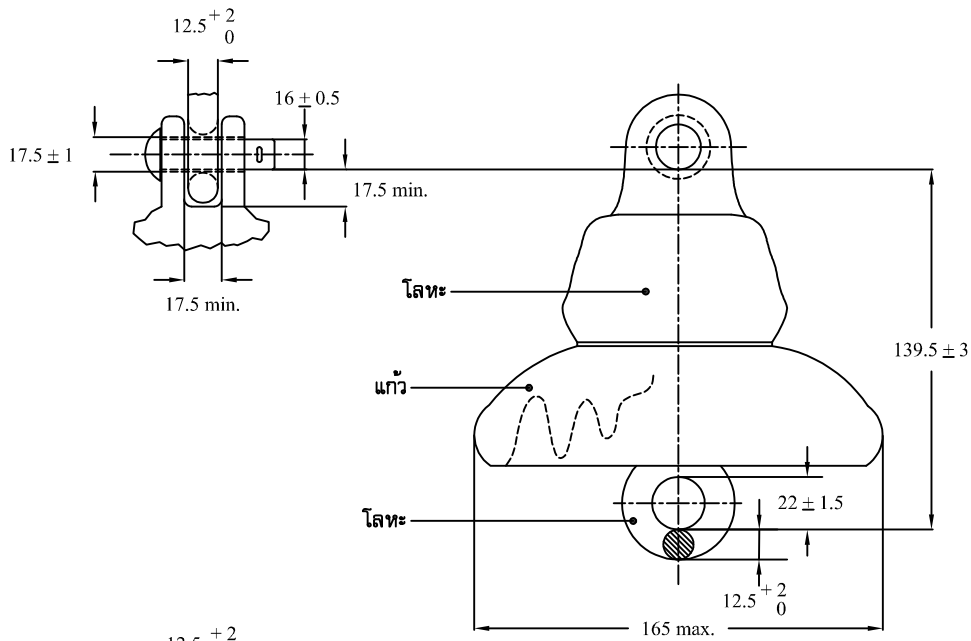

Class 52-1

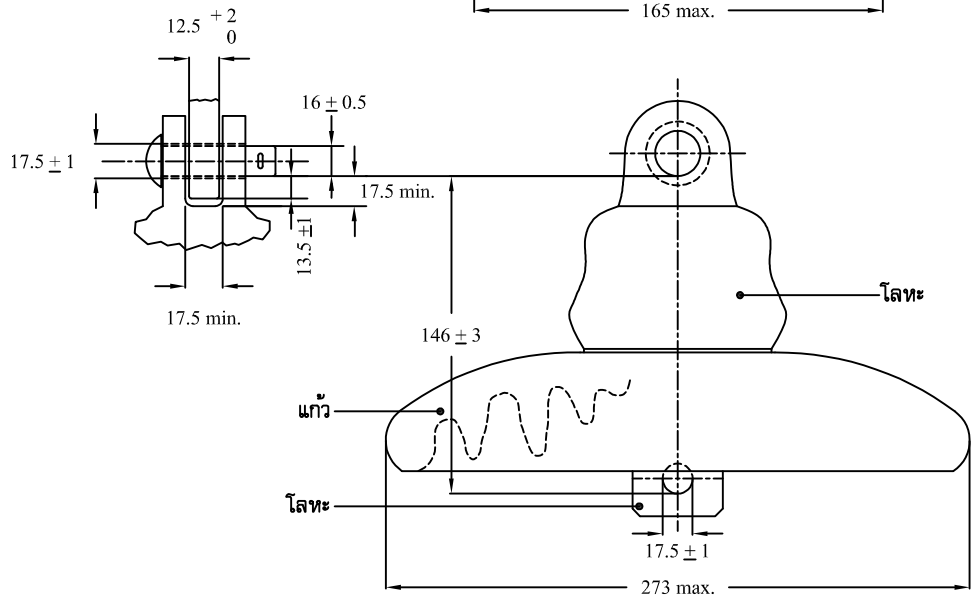

Class 52-4

All dimensions are in mm

TIS 563 SUSPENSION-TYPE TOUGHENED GLASS INSULATOR		Class 52-1	Class 52-4
MINIMUM DIMENSIONS	Leakage distance	mm	178
			292
MECHANICAL VALUES	Combined mechanical and electrical strength	mm	44
	Mechanical impact strength	N-m	5.0
	Tension proof	kN	22
	Time load	kN	27
ELECTRICAL VALUES	Low-frequency dry flashover	kV	60
	Low-frequency wet flashover	kV	30
	Critical-impulse flashover, positive	kV	100
	Critical-impulse flashover, negative	kV	100
	Low-frequency puncture	kV	80
RADIO-INFLUENCE VOLTAGE DATA	Low-frequency test voltage, rms to ground	kV	7.5
	Maximum RIV at 1,000 kHz	μV	50

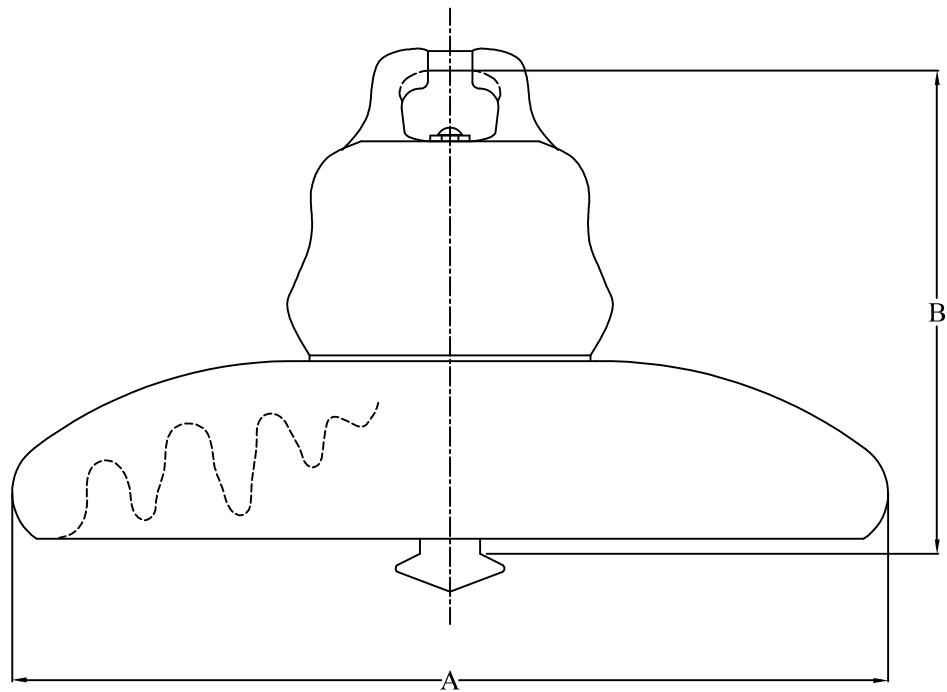

TIS 354 SUSPENSION-TYPE PORCELAIN INSULATOR			Type C Class 52-3	Type E Class 52-8
DIMENSIONS	A, maximum	mm	273	298
	B	mm	146±3	146±3
MINIMUM DIMENSIONS	Leakage distance	mm	292	279.5
MECHANICAL VALUES	Combined mechanical and electrical strength	kN	66.72	160.13
	Mechanical impact strength	cm-N	621.34	1,016.73
	Tension proof	kN	33.36	80.06
	Time load	kN	44.48	106.75
ELECTRICAL VALUES	Low-frequency dry flashover	kV	80	80
	Low-frequency wet flashover	kV	50	50
	Critical-impluse flashover, positive	kV	125	125
	Critical-impluse flashover, negative	kV	130	130
	Low-frequency puncture	kV	110	110
RADIO-INFLUENCE VOLTAGE DATA	Low-frequency test voltage, rms to ground	kV	10	10
	Maximum RIV at 1,000 kHz	µV	50	50
COLOUR OF INSULATOR			BROWN	

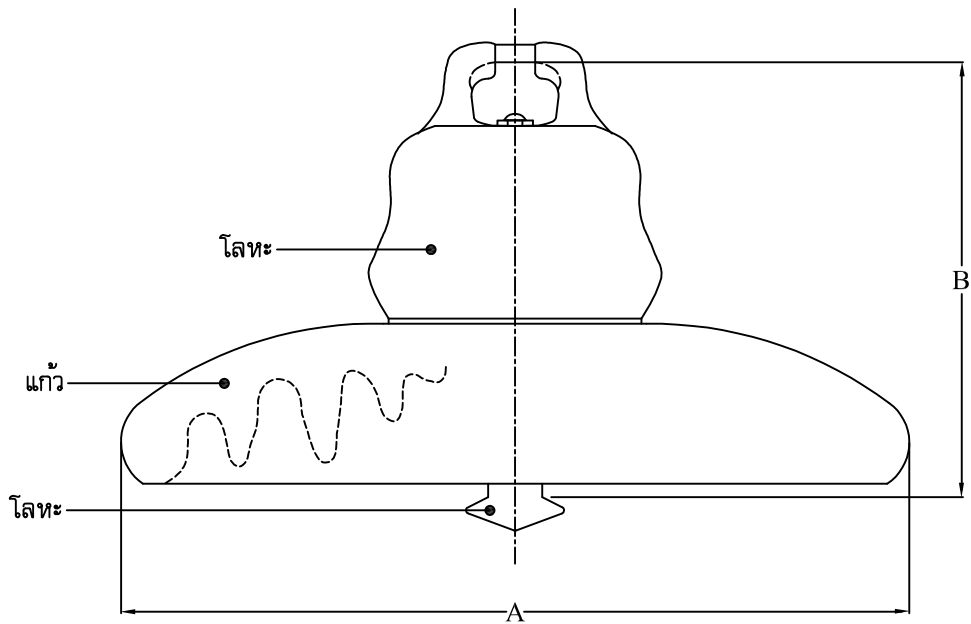

TIS 563 SUSPENSION-TYPE TOUGHENED GLASS INSULATOR			Class 52-3	Class 52-8
DIMENSIONS	A, maximum	mm	273	298
	B	mm	146 ₊₃	146 ₊₃
MINIMUM DIMENSIONS	Leakage distance	mm	292	279
MECHANICAL VALUES	Combined mechanical and electrical strength	kN	67	160
	Mechanical impact strength	cm-N	6.0	10
	Tension proof	kN	33.5	80
	Time load	kN	44	107
ELECTRICAL VALUES	Low-frequency dry flashover	kV	80	80
	Low-frequency wet flashover	kV	50	50
	Critical-impulse flashover, positive	kV	125	125
	Critical-impulse flashover, negative	kV	130	130
	Low-frequency puncture	kV	110	110
RADIO-INFLUENCE VOLTAGE DATA	Low-frequency test voltage, rms to ground	kV	10	10
	Maximum RIV at 1,000 kHz	μV	50	50

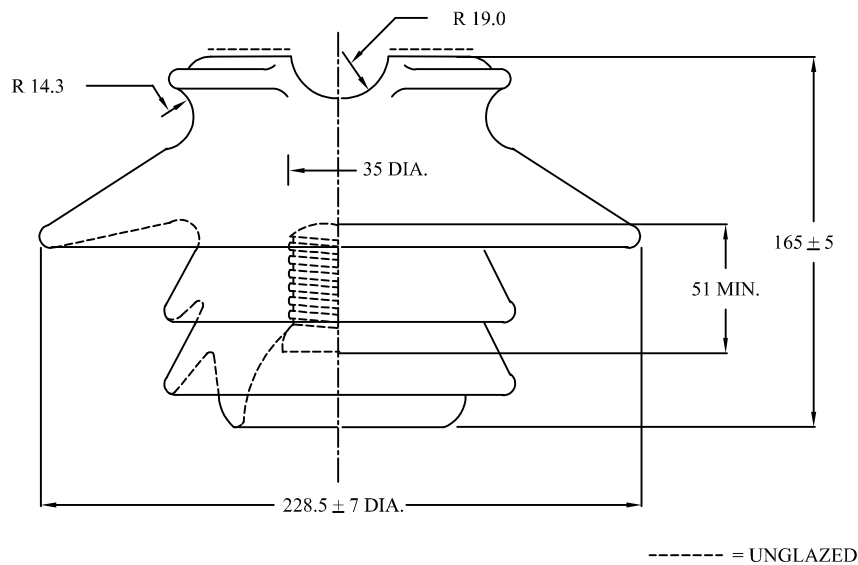

Note

1. If high-resistance coatings are applied to the insulator, such coatings shall be considered as effective leakage surfaces, and the distance over them shall be included in the leakage distance.
2. All dimensions are in mm.
3. Top-wire groove shall seat a 36.5 mm diameter mandrel.
4. Side-wire groove shall seat a 27 mm diameter mandrel.

TIS 279 PIN-TYPE INSULATOR			Type B Class 56-2
MINIMUM DIMENSIONS	Leakage Distance	mm	432
	Dry-arcing distance	mm	210
	Pin height	mm	178
MECHANICAL VALUE	Cantilever strength	kN (lb)	13.3 (3,000)
ELECTRICAL VALUES	Low-frequency dry flashover	kV	110
	Low-frequency wet flashover	kV	70
	Critical-impulse flashover, positive	kV	175
	Critical-impulse flashover, negative	kV	225
	Low-frequency puncture	kV	145
RADIO-INFLUENCE VOLTAGE DATA	Low-frequency test voltage, rms to ground	kV	22
	Maximum RIV at 1,000 kHz, Radio freed	μV	100
COLOUR OF INSULATOR			BROWN

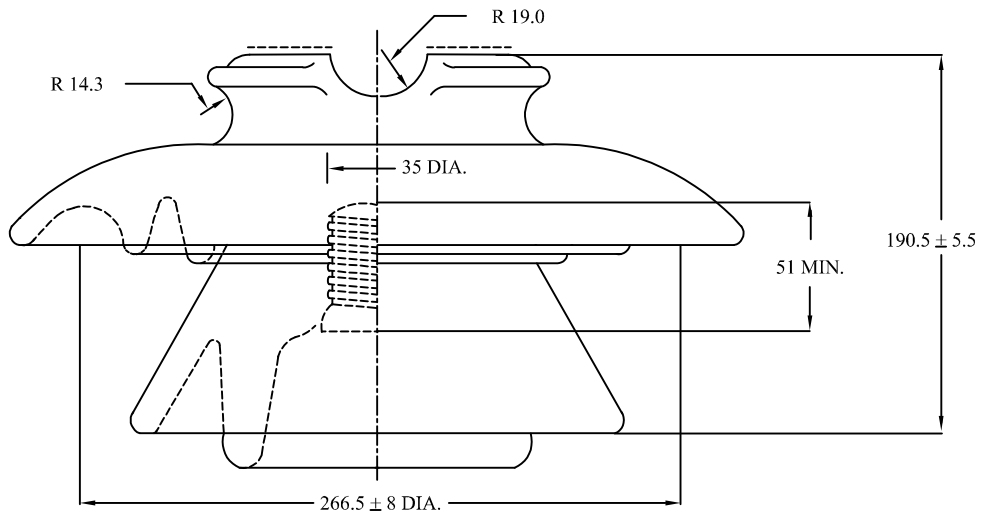

----- = UNGLAZED

Note

1. If high-resistance coatings are applied to the insulator, such coatings shall be considered as effective leakage surfaces, and the distance over them shall be included in the leakage distance.
2. All dimensions are in mm.
3. Top-wire groove shall seat a 35 mm diameter mandrel.
4. Side-wire groove shall seat a 27 mm diameter mandrel.

TIS 279 PIN-TYPE INSULATOR		Type C Class 56-3	
MINIMUM DIMENSIONS	Leakage distance	mm	533.5
	Dry-arcing distance	mm	241.5
	Pin height	mm	203
MECHANICAL VALUE	Cantilever strength	kN (lb)	13.3 (3,000)
ELECTRICAL VALUES	Low-frequency dry flashover	kV	125
	Low-frequency wet flashover	kV	80
	Critical-impulse flashover, positive	kV	200
	Critical-impulse flashover, negative	kV	265
	Low-frequency puncture	kV	165
RADIO-INFLUENCE VOLTAGE DATA	Low-frequency test voltage, rms to ground	kV	30
	Maximum RIV at 1,000 kHz, Radio freed	µV	200
COLOUR OF INSULATOR		BROWN	

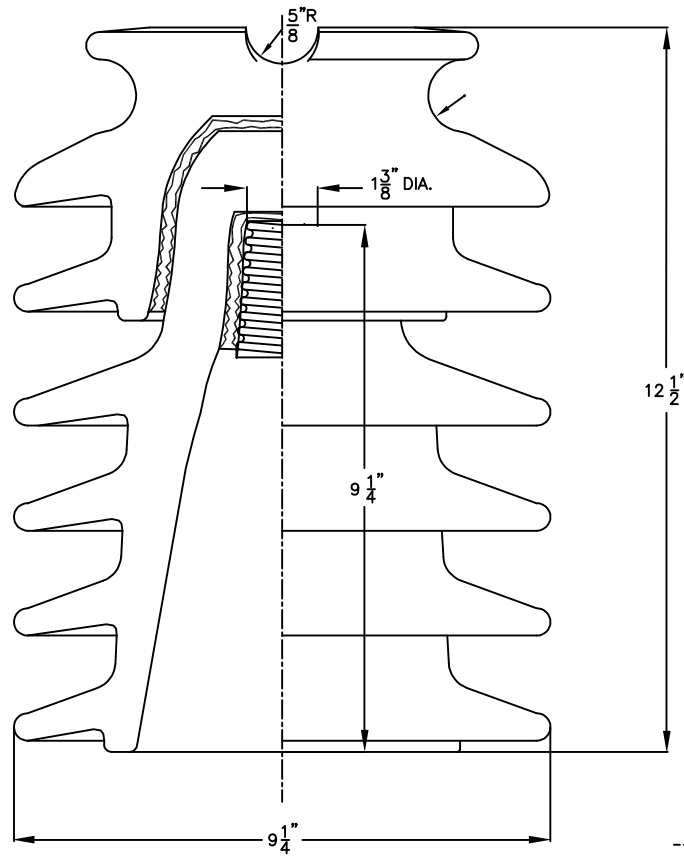

----- = UNGLAZED
 CATALOGUE NO. HRAA-025571C

Catalogue No.		HRAA-025571C	
Leakage Distance		inch	36 3/4
Dry Arcing Distance		inch	14 1/4
Cantiliver strength		lb	3,000
Minimum Flashover Voltage	Low Frequency	Dry	kV 140
		Wet	kV 115
	Critical Impluse	Positive	kV 210
		Negative	kV 245
Withstand Voltage	Low Frequency	Dry	kV 120
		Wet	kV 90
	Critical Impluse	kV 190	
Low Frequency Puncture Voltage		kV	210
Radio Influence Voltage Data	Test Voltage to Ground		kV 30
	Maximum RIV at 1,000 kHz		µV 200
COLOUR OF INSULATOR			BROWN

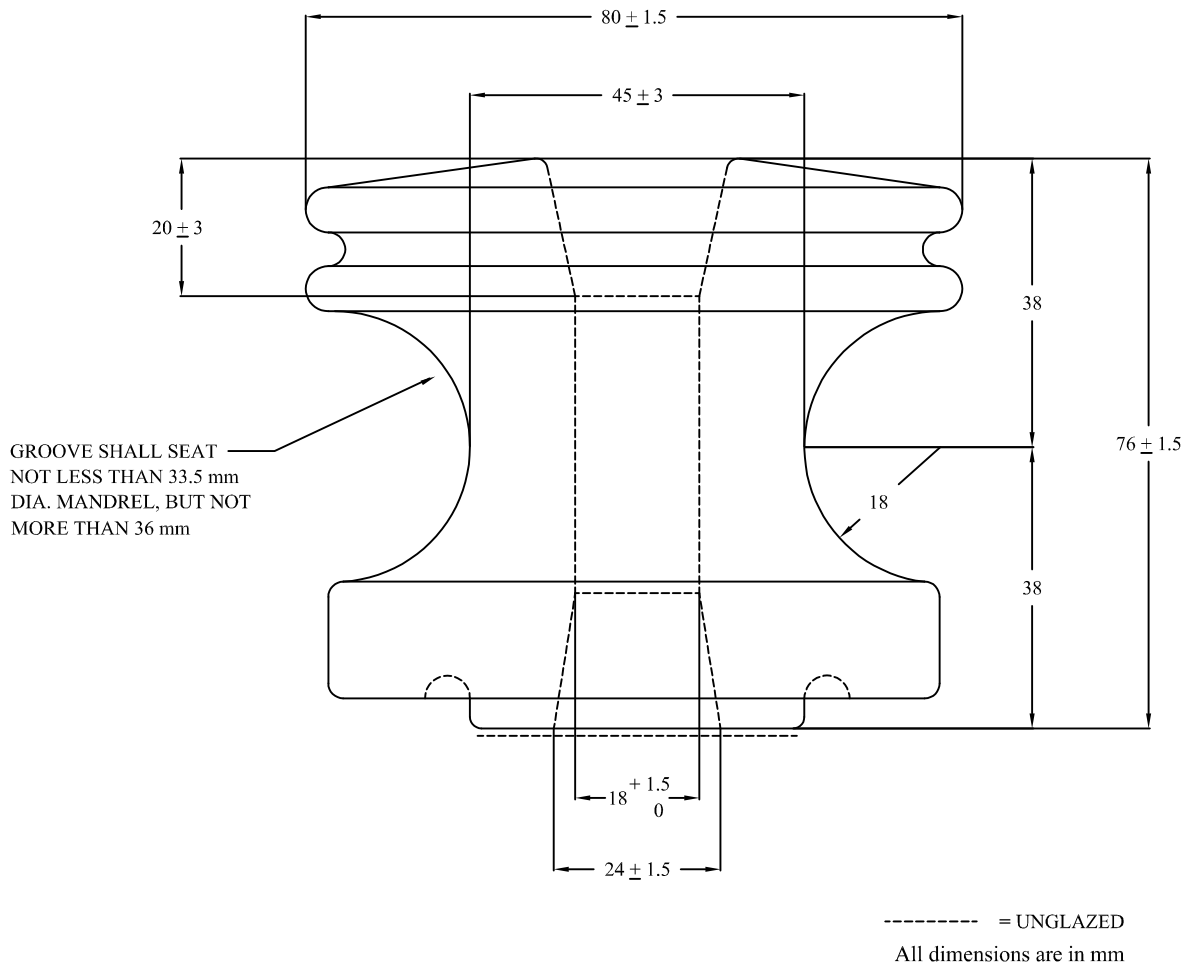

TIS 227 SPOOL-TYPE INSULATOR			Type B Class 53-2
MECHANICAL VALUE	Transverse strength	kN (lb)	13.3 (3,000)
ELECTRICAL VALUES	Low-frequency dry flashover	kV	25
	Low-frequency wet flashover, Vertical	kV	12
	Low-frequency wet flashover, Horizontal	kV	15
COLOUR OF INSULATOR			BROWN

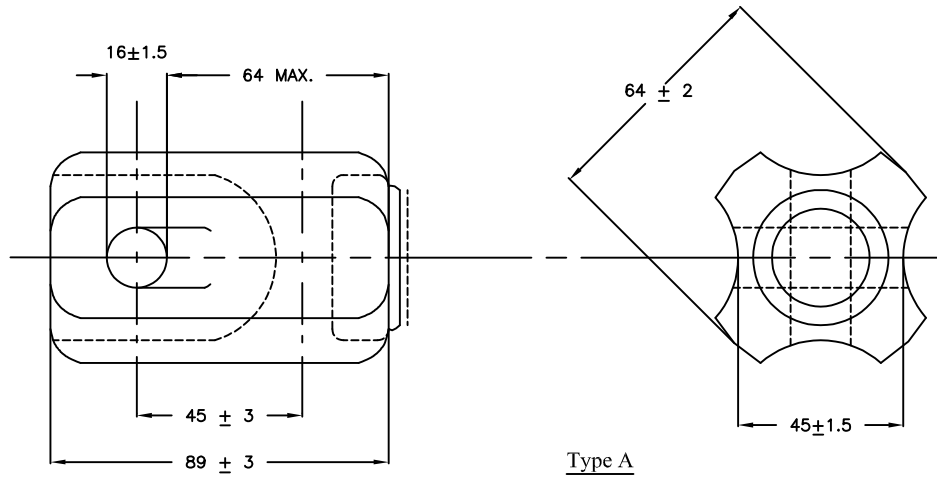

Type A

----- = UNGLAZED
All dimensions are in mm

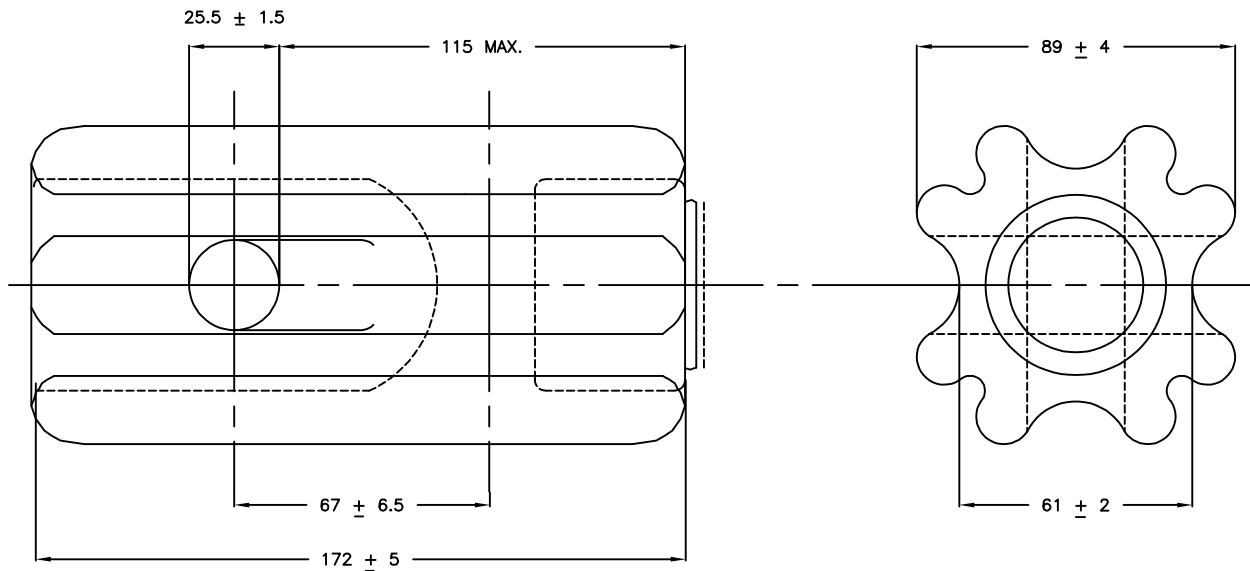

Type D

----- = UNGLAZED
All dimensions are in mm

TIS 280 STRAIN-TYPE INSULATOR			Type A Class 54-1	Type D Class 54-4
MINIMUM DIMENSIONS	Leakage distance	mm	41.5	76
MECHANICAL VALUES	Tension strength	kN (lb)	44.5 (10,000)	89 (20,000)
ELECTRICAL VALUES	Low-frequency dry flashover	kV	25	40
	Low-frequency wet flashover	kV	12	23
COLOUR OF INSULATOR			BROWN	