

**PROVINCIAL ELECTRICITY AUTHORITY**
**ELECTRICAL AND MECHANICAL ENGINEERING DIVISION**
**CLAMP WITH BOLT FOR GALVANIZED STEEL WIRE STRANDS**

Specification No. <b>RHDW-033/2565</b>	Approved date:	Rev. No.: -	From No. 93-2.1	Page 1 of 8
--	----------------	-------------	-----------------	-------------

**C Material, equipment, and specifications for CLAMP WITH BOLT FOR GALVANIZED STEEL WIRE STRANDS**

**C1 General material and packing instructions**

Additional to the general instructions, the following shall be observed:

**1a Scope**

These specifications cover clamp with bolt for galvanized steel wire strands designed to clamp overhead ground wire and earthing wire for overhead ground wire installation.

**1b Standards**

Clamp with bolt for galvanized steel wire strands shall be coated by means of non-electrolytically applied zinc flake coating in accordance with standard below.

TIS 2408 - 2551 : Fasteners – non-electrolytically applied zinc flake coatings

PEA will also accept the clamp coated in accordance with the later edition of the above standards.

**1c Principal requirement**

**1c.1 Service conditions and installation**

Clamp with bolt for galvanized steel wire strands shall be designed and constructed for outdoor installation, and suitable for operation under the following conditions:

Altitude : up to 1,000 m above sea level

Ambient air temperature : up to 40<sup>o</sup>C

Average relative humidity in any one year : up to 94%

Climatic condition : tropical climate

**1c.2 Construction and characteristics**

The clamp shall be suitable for using with galvanized steel wire strands in accordance with TIS 404 and shall have smooth surfaces, free from burrs and edges.

The clamp shall be made of steel and shall be coated by means of non-electrolytically applied zinc flake without chromate (fZnnc) to protect corrosion with coating thickness as specified in **Table 1**.



การไฟฟ้าส่วนภูมิภาค  
PROVINCIAL ELECTRICITY AUTHORITY

## PROVINCIAL ELECTRICITY AUTHORITY

### ELECTRICAL AND MECHANICAL ENGINEERING DIVISION

#### CLAMP WITH BOLT FOR GALVANIZED STEEL WIRE STRANDS

Specification No. RHDW-033/2565

Approved date:

Rev. No.: -

From No. 93-2.1

Page 2 of 8

#### 1c.3 Coating thickness of the clamp

Coating thickness shall be in accordance with **Table 1**

**Table 1**

**Coating thickness of the clamp**

No.	Components of the clamp	Minimum coating thickness
1	Body of square carriage bolt	12 $\mu$ m
2	Body of the clamp	

#### 1c.4 Marking

Each clamp shall be marked by mean of emboss, engraving, stamping or laser marking on the body before coated with zinc flake at least listed below.

- (1) Manufacturer's name or Trademark
- (2) Clamping range
- (3) Model or drawing number or catalog number of the clamp
- (4) Purchase order number

Marking shall be obvious after coated.

#### 1d Packing

The clamp shall be packed in the suitable carton box. Number of clamps per carton box shall be not more than 50 pieces.

Each carton box shall be marked with the name of manufacturer, net weight and gross weight.

#### 1e Test and test reports

##### 1e.1 Type tests

The proposed clamp shall pass the type test items with reference standards and test method as specified in **Table 2**.

**The cost of all tests and report shall be borne by the Bidders/Manufacturers.**



การไฟฟ้าส่วนภูมิภาค  
PROVINCIAL ELECTRICITY AUTHORITY

## PROVINCIAL ELECTRICITY AUTHORITY

### ELECTRICAL AND MECHANICAL ENGINEERING DIVISION

#### CLAMP WITH BOLT FOR GALVANIZED STEEL WIRE STRANDS

Specification No. RHDW-033/2565

Approved date:

Rev. No.: -

From No. 93-2.1

Page 3 of 8

**Table 2**

#### Type test items of the clamp

No.	Test Items	Reference standards/Test method
1	Weight of the clamp	PEA's test procedure in (1)
2	Visual and dimension check	PEA's test procedure in (2)
3	Coating thickness	PEA's test procedure in (3)
4	Clamp bolt tightening test	PEA's test procedure in (4)

**Note:** At least five (5) samples of bolt clamp are required for the type tests.

Before the type tests are proceeded, all samples, drawing showing specified dimensions and all information according to PEA's drawing will be submitted to PEA for approval and the samples will be signed by PEA's representative.

One sample of the submitted clamp will be kept by PEA (by Electrical Equipment Standard and Quality Control Division) and will be used as a reference sample for bid consideration and acceptance processes.

The other samples will be sent to acknowledged independent testing laboratories/institutes, which have qualification mentioned below, for type test in accordance with test items No. 1 - 4 in **Table 2**, step by step, respectively as follows:

#### (1) Weight of the clamp

The four (4) samples shall be weighted by digital weighing scale with 1-gram accuracy, or better. The weight of each sample and average weight shall be recorded in the report.

#### (2) Visual and dimension check

All samples shall have smooth surfaces, free from burrs, and the edges and fillets shall be rounded. Each sample shall have markings in accordance with clause **1c.3**, except purchase order number is not necessary to be marked at this stage.

Dimensions of each sample shall be measured and recorded in the test report. The dimensions of all samples shall be according to PEA's drawing and drawings of manufacturer with tolerances specified in **Table 3**.



การไฟฟ้าส่วนภูมิภาค  
PROVINCIAL ELECTRICITY AUTHORITY

## PROVINCIAL ELECTRICITY AUTHORITY

### ELECTRICAL AND MECHANICAL ENGINEERING DIVISION

#### CLAMP WITH BOLT FOR GALVANIZED STEEL WIRE STRANDS

Specification No. RHDW-033/2565

Approved date:

Rev. No.: -

From No. 93-2.1

Page 4 of 8

**Table 3**

#### Tolerances of visual check and dimension check

Dimension	Tolerance
Up to and including 35 mm	± 0.7 mm
Over 35 mm	± 2% mm or ± 5 mm, whichever is lower

#### (3) Coating thickness

Coating thickness of all samples shall be measured by coating thickness gage. A main part, clamp body, and a fastener part, consisting of bolts and nuts, of each sample shall be randomly measured of zinc flake coatings thickness at 10 points for each part.

Minimum thickness of each point shall be according to **Table 1**.

#### (4) Clamp bolt tightening test

Tighten the bolts of the clamp to the specified value; see **C3 Schedule of detailed requirement** of this specification. All part of the clamp shall not show any sign of crack.

The type test of the clamp shall be conducted or inspected by the acknowledged independent testing laboratories/institutes as follows:

- (1) Independent laboratories/institutes which are members of the Short-circuit Testing Liaison (STL) or independent laboratories/institutes which are accredited according to TIS 17025 or ISO/IEC 17025 with the scope of accreditation covered the relevant test items, standards and equipment. The certification and scope of accreditation of the independent laboratories/institutes shall be submitted with the bid for consideration.
- (2) Thailand's national laboratories, institutes, universities and electric utilities, as follow:
  - NSTDA Characterization and testing service center (NCTC)
  - Thailand Institute of Scientific and Technological Research (TISTR)
  - National Metal and Materials Technology Center (MTEC)
  - Electrical and Electronic Products Testing Center (PTEC)
  - Thai Industrial Standards Institute (TISI)
  - Electrical and Electronics Institute (EEI)
  - Department of Science Service (DSS)
  - Testing Laboratory, Electrical Engineering Department, Faculty of Engineering, Chulalongkorn University
  - Electricity Generating Authority of Thailand (EGAT)
  - Metropolitan Electricity Authority (MEA)
  - Provincial Electricity Authority (PEA)



การไฟฟ้าส่วนภูมิภาค  
PROVINCIAL ELECTRICITY AUTHORITY

## PROVINCIAL ELECTRICITY AUTHORITY

### ELECTRICAL AND MECHANICAL ENGINEERING DIVISION

#### CLAMP WITH BOLT FOR GALVANIZED STEEL WIRE STRANDS

Specification No. RHDW-033/2565

Approved date:

Rev. No.: -

From No. 93-2.1

Page 5 of 8

(3) Other laboratories as follow:

- In case the foreign manufacturers have experience of more than twenty (20) years in design, manufacture and sell clamps used in the power system, PEA will accept type test report(s) conducted by the manufacturer's laboratory or other independent laboratories without qualification mentioned in (1) or (2). Documents showing the manufacturer's experience such as reference list shall be submitted with the bid for consideration.
- The bidders or manufacturers who prefer to carry out the type tests of the clamp with other laboratories without the qualification mentioned above, the detail of laboratory and the test facilities shall be submitted to PEA for approval before proceeding the tests and before the bid closing date. PEA reserves the right to send representatives to inspect or witness the tests.

The type test reports conducted by the laboratories/institutes in Thailand or local manufacturers shall be valid within five (5) years counted from the issued date in the test report to the bid closing date.

The type test reports conducted by the laboratories/institutes in other countries shall be valid within ten (10) years counted from the issued date in the test report to the bid closing date.

**The type test reports shall include the necessary as follow:**

- Outline drawing of the clamp, showing dimensions according to PEA's drawing.
- The color photographs of the clamp as following:
  - Manufacturer's name or Trademark
  - Type/Model
  - Clamping range of clamp

**The cost of all tests and report shall be borne by the Bidders or manufacturers.**

**The type test reports shall be submitted with the bid.**

PEA will also accept other documents instead of the type test reports in the following cases:

- (1) In case the proposed clamp has been sold to PEA at PEA's Procurement Department (from PEA's head office), The bidder can submit the Purchase Order (PO) on the bid closing date, or
- (2) In case the proposed clamp has been registered for PEA Product Acceptance<sup>(1)</sup>, the Bidder can submit the valid registration certificate on the bid closing date, or
- (3) In case the proposed clamp has been registered for Product lists for transmission and substation turnkey project<sup>(2)</sup>, the Bidder can submit the valid registration certificate on the bid closing date.

However the document in case (1), (2) and (3) mentioned above shall be proved by the bidding committee that clamp specified in the PO or registration certificate is the same product, type/model and all ratings as the proposed bolt clamp for this bid.



การไฟฟ้าส่วนภูมิภาค  
PROVINCIAL ELECTRICITY AUTHORITY

## PROVINCIAL ELECTRICITY AUTHORITY

### ELECTRICAL AND MECHANICAL ENGINEERING DIVISION

#### CLAMP WITH BOLT FOR GALVANIZED STEEL WIRE STRANDS

Specification No. RHDW-033/2565

Approved date:

Rev. No.: -

From No. 93-2.1

Page 6 of 8

- Note:
- (1) PEA Product Acceptance (PPA) is the process for enhancing quality of electrical apparatus which PEA procure by making quality control system and certification of product's quality by reliable Certification Body (CB). PPA is taken responsibility by Electrical Equipment Standard and Quality Control Division.
  - (2) Product lists for transmission and substation turnkey project is the process of registration of electrical apparatus used in PEA's power system. Product lists is taken responsibility by Substation Project Management Division.

#### 1e.2 Acceptance tests

PEA reserves the right to have acceptance tests conducted by PEA's laboratory or by manufacturer's factory or by acknowledge independent testing laboratories as mentioned in **1e.1**

In case the tests conducted by manufacturer's factory or by acknowledge independent testing laboratories, PEA reserves the right to send representatives to witness the tests.

**The cost of the acceptance tests and report shall be borne by the Contractor.**

PEA will randomly choose the samples of the bolt clamp per delivery lot for testing with the number specified in **Table 4**.

**Table 4**

**Number of samples for acceptance tests**

Number of bolt clamp for each delivery lot (sets)	Number of samples (sets)
not more than 50	2
51 to 100	4
More than 100	6

**Note:** - The samples shall be not returned and shall be not used in the system.

- After the tests, the additional clamp, with the equal number of the samples specified in **Table 4**, shall be supplied by the contractor with free of charge to complete the number of the clamp in the purchase contract.

The samples shall pass the acceptance test items as same as the type tests item No. 1 – 4 specified in **Table 2**, respectively.

For testing of weight of the clamp, the weight of each sample shall not differ by  $\pm 5\%$  of the average wight recorded in the type test report.

#### 1e.3 Routine tests

Each clamp for galvanized steel wire strands shall pass the manufacturer's standard routine tests with the test items as follow:

- (1) Dimension check
- (2) Weight of clamp
- (3) Coating thickness



การไฟฟ้าส่วนภูมิภาค  
PROVINCIAL ELECTRICITY AUTHORITY

## PROVINCIAL ELECTRICITY AUTHORITY

### ELECTRICAL AND MECHANICAL ENGINEERING DIVISION

#### CLAMP WITH BOLT FOR GALVANIZED STEEL WIRE STRANDS

Specification No. RHDW-033/2565	Approved date:	Rev. No.: -	From No. 93-2.1	Page 7 of 8
---------------------------------	----------------	-------------	-----------------	-------------

List of routine tests shall be submitted with the bid

The contractor shall supply the reports of routine tests to PEA before shipment/delivery for each ordered clamp.

#### 1f Guarantee

The Contractor shall guarantee the quality for two (2) years commencing from the date PEA receive the above-mentioned clamp in the condition as specified in note below.

#### Note:

ภายในกำหนดระยะเวลารับประกันคุณภาพ หากการไฟฟ้าส่วนภูมิกานำ Clamp ไปใช้งานตามปกติแล้วปรากฏว่าชำรุด ขัดข้อง หรือบกพร่อง คู่สัญญาจะต้องนำ Clamp อันใหม่มาเปลี่ยนทดแทนของที่ชำรุดภายใน 30 วัน นับถัดจากวันที่ได้รับแจ้งจากการไฟฟ้าส่วนภูมิภาค และหากการชำรุด ขัดข้อง หรือบกพร่องดังกล่าว มีสาเหตุมาจากคุณสมบัติที่ไม่เป็นไปตามสเปคของการไฟฟ้าส่วนภูมิภาค คู่สัญญาจะต้องเปลี่ยนสิ่งของที่ส่งมอบตามสัญญาทั้งหมดให้แก่การไฟฟ้าส่วนภูมิภาค โดยไม่คิดค่าใช้จ่ายใดๆ ทั้งสิ้น



การไฟฟ้าส่วนภูมิภาค  
PROVINCIAL ELECTRICITY AUTHORITY

## PROVINCIAL ELECTRICITY AUTHORITY

### ELECTRICAL AND MECHANICAL ENGINEERING DIVISION

#### CLAMP WITH BOLT FOR GALVANIZED STEEL WIRE STRANDS

Specification No. RHDW-033/2565

Approved date:

Rev. No.: -

From No. 93-2.1

Page 8 of 8

#### C2 Material and packing data of the proposed clamp shall be submitted with the bid

##### Critical documents of the proposed clamp

No.	Required technical document	Proposed technical document	Reference document (Folder/Page No.)
1	Type test reports (See 1e.1), or	<input type="checkbox"/> YES <input type="checkbox"/> No	
	Purchase Order (PO) from PEA's Procurement Department (from PEA's head office), or	<input type="checkbox"/> YES <input type="checkbox"/> No	
	Registration certificate of PEA Product Acceptance, or	<input type="checkbox"/> YES <input type="checkbox"/> No	
	Registration certificate of Product lists for transmission and substation turnkey project	<input type="checkbox"/> YES <input type="checkbox"/> No	
2	Outline drawing(s) of the clamp, showing dimensions (See 1c.2)	<input type="checkbox"/> YES <input type="checkbox"/> No	
3	List of routine test (See 1e.3)	<input type="checkbox"/> YES <input type="checkbox"/> No	
4	Packing detail according to (See 1d)	<input type="checkbox"/> YES <input type="checkbox"/> No	

##### Note:

Critical documents shall be submitted with the bid; otherwise, the proposal shall be rejected.



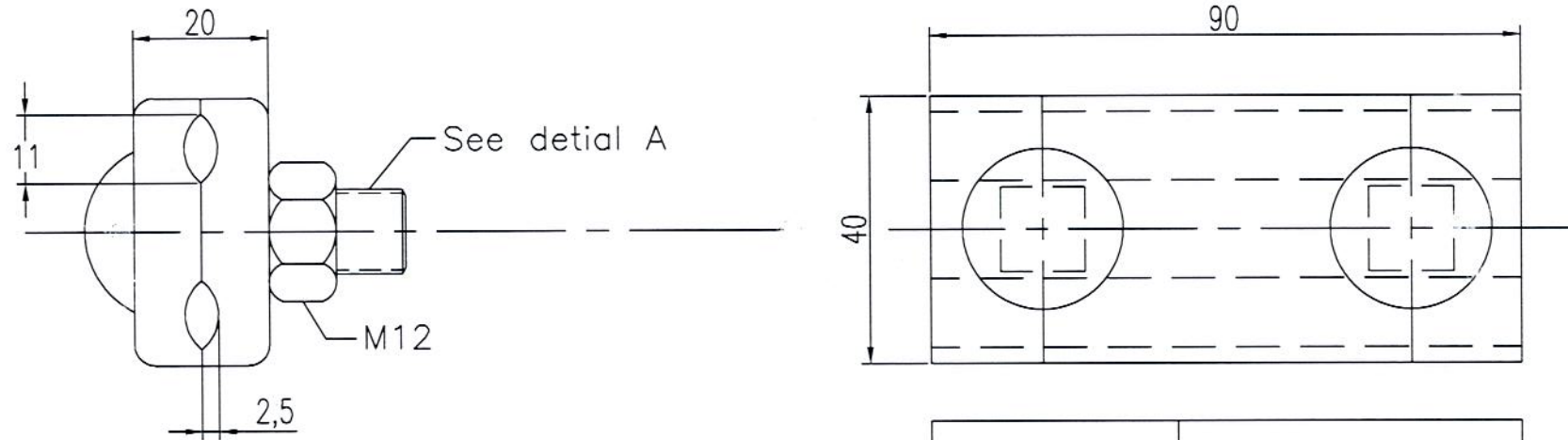

Detail A

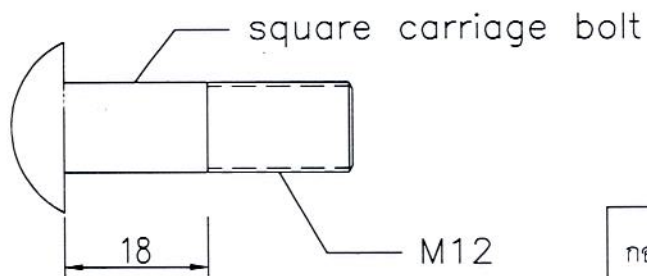

DIMENSION mm	TOLERANCE
Up to and including 35	±0.7 mm
Over 35	±2% mm or ±5 mm whichever is lower



กองวิศวกรรมไฟฟ้าและเครื่องกล ฝ่ายวิศวกรรม	การไฟฟ้าส่วนภูมิภาค	ใช้แทนแบบ..... ถูกแทนโดยแบบ..... เขียนแบบเสร็จวันที่ 9.ก.พ. 2564 แก้แบบวันที่..... มีดีเป็น..... มีลิสมิตร..... มาตราส่วน..... แบบเลขที่..... SB2-015/64001 แผ่นที่.....1.....ของจำนวน.....1.....แผ่น
ผู้เขียน..... ณรงค์เดช โพธิ์มด วิศวกร..... ณรงค์เดช หัวหน้าแผนก..... / วิศวกรรม ผู้อำนวยการกอง..... ผู้อำนวยการฝ่าย.....	แคลมป์ปลั๊ก 2 ตัว สำหรับลวดเหล็กตีเกลียว 25 - 50 ตร.มม.	
	CLAMP WITH BOLTS FOR GALVANIZED STEEL WIRE STRANDS	



**PROVINCIAL ELECTRICITY AUTHORITY**  
**ELECTRICAL AND MECHANICAL ENGINEERING DIVISION**

**Specification No. : RHDW-033/2565      CLAMP WITH BOLT FOR GALVANIZED STEEL WIRE STRANDS**

**Page 1 of 1**

**C3 Schedule of detailed requirement**

**Invitation to Bid No. : ឧ.3 កម្មសិទ្ធិ(ឧប.)EBD020/2566**

Item	PEA Material No.	Quantity	Description
1	1010230012	21,000set(s)	Clamp with bolt for using with galvanized steel wire strand, size 25-50 mm <sup>2</sup> (dimeter range 6.3-9 mm) see Drawing No. SB2-015/64001.  Clamp with bolt : 2-bolt type  Withstand tightening torque of at least : 54 N-m



**PROVINCIAL ELECTRICITY AUTHORITY**  
**ELECTRICAL AND MECHANICAL ENGINEERING DIVISION**

**Specification No.: RHDW-033/2565: CLAMP WITH BOLT FOR GALVANIZED STEEL WIRE STRANDS**

Page 1 of 1

**C4 Price schedule**

**Invitation to Bid No.:** ฉ.3 กบญ.(จพ.)EBD020/2566

**Manufacturer :**

**Country of origin :**

**Trade-mark :**

Item	PEA Material No.	Catalogue No.	Description	Quantity	Unit Cost (See details & conditions attached)	Total Cost (See details & conditions attached)
1	1010230012		Clamp with bolt for using with galvanized steel wire strand, Size.....mm <sup>2</sup> (dimeter range.....mm) Clamp with bolt : 2-bolt type Withstand tightening torque of at least : ..... N-m	21,000 set(s)		