



เอกสารเพิ่มเติมแนบท้ายรายละเอียดสเปค
(ADDENDUM)

เอกสารเพิ่มเติมแนบท้ายรายละเอียดสเปค (ADDENDUM) นี้ให้ถือเป็นส่วนหนึ่งของสเปคอ้างอิงเลขที่ RTRN-035/2561

การทดสอบ Lightning impulse test

กำหนดรายละเอียดการทดสอบ lightning impulse test เพิ่มเติมในหัวข้อ 1e.2.2 Test procedure of Type test and Short-circuit withstand test ข้อ (3) และ 1 e.5 Acceptance test items and acceptance test procedures ดังต่อไปนี้

(1) Test connections

For the lightning impulse test on the LV windings ($U_m \leq 1.1$ kV), PEA will accept test connections as the following:

CASE 1:

The impulse test sequence is applied to each of line terminals of the tested winding in succession. The other line terminals of the transformer shall be earthed directly or through an impedance, or

CASE 2:

The impulse test is applied to all the LV terminals (including the LV neutral) connected together with the higher voltage terminals earthed.

(2) Test voltage

The standard lightning-impulse voltage and tolerances shall be in accordance with the IEC 60060-1 as the table below:

Description	HV	LV
Test voltage value	125 kV, peak $\pm 3\%$ (for 22 kV system) 170 kV, peak $\pm 3\%$ (for 33 kV system)	30 kV, peak $\pm 3\%$
Front time	1.2 μs $\pm 30\%$	
Time to half-value	50 μs $\pm 20\%$	
Relative overshoot magnitude	not exceed 10 %	

The minimum information on the waveshape in the test report shall consist of test voltage, front time (T1), time to half-value (T2) and overshoot.



การไฟฟ้าส่วนภูมิภาค
PROVINCIAL ELECTRICITY AUTHORITY

PROVINCIAL ELECTRICITY AUTHORITY

TECHNICAL SPECIFICATION DIVISION

THREE-PHASE TRANSFORMERS FOR 22 kV AND 33 kV 50 Hz DISTRIBUTION SYSTEMS WITH ABILITY TO WITHSTAND SHORT CIRCUIT

Specification No. RTRN-035/2561

Approved date: **04 NOV 2020**

Rev. No.: 0

Form No.

Page 1 of 2

เอกสารเพิ่มเติมแนบท้ายรายละเอียดสเปค 2 (ADDENDUM 2)

เอกสารเพิ่มเติมแนบท้ายรายละเอียดสเปค (ADDENDUM 2) นี้ให้ถือเป็นส่วนหนึ่งของสเปคอ้างอิงเลขที่ RTRN-035/2561

การทดสอบเพื่อการตรวจรับ (Acceptance test)

รายละเอียดการทดสอบเพื่อการตรวจรับนี้ ให้ใช้แทนหัวข้อ 1e.5.2 Acceptance test procedures ในสเปค

- (1) การทดสอบเพื่อการตรวจรับตามหัวข้อ 1e.5.1(1) ถึง (7) และหัวข้อที่ (11)

ให้สุ่มตัวอย่างจากหม้อแปลงที่จัดส่งในแต่ละงวด โดยสุ่มตัวอย่างแต่ละรายการ (Item) ที่มีหมายเลขรหัสพัสดุเดียวกัน เกณฑ์การพิจารณาให้เป็นไปตามตารางที่ 1 ดังนี้

ตารางที่ 1

จำนวนหม้อแปลงที่ จัดส่งแต่ละงวด ⁽¹⁾ (เครื่อง)	จำนวนตัวอย่าง ที่ส่งทดสอบเพื่อการตรวจรับ (เครื่อง)	จำนวนตัวอย่างสูงสุด ที่ยอมรับให้ทดสอบไม่ผ่าน (เครื่อง)
2 ถึง 15	2	0
16 ถึง 25	3	0
26 ถึง 90	5	0
91 ถึง 150	8	0
151 ถึง 500	13	1
มากกว่า 500	20	1

⁽¹⁾ จำนวนหม้อแปลงที่จัดส่งในแต่ละงวด แยกตามหมายเลขรหัสพัสดุ

ทั้งนี้ หากจำนวนหม้อแปลงที่ไม่ผ่านการทดสอบมากกว่าจำนวนตัวอย่างสูงสุดที่ยอมรับให้ทดสอบไม่ผ่านตามตารางที่ 1 ให้คณะกรรมการตรวจรับพัสดุฯ ดำเนินการตามขั้นตอนการตรวจรับพัสดุในหลักเกณฑ์การตรวจรับพัสดุ กฟภ.

- (2) การทดสอบเพื่อการตรวจรับตามหัวข้อ 1e.5.1(8), (9) และ (10) สำหรับงวดแรกของสัญญา ที่ผ่านการทดสอบในข้อ (1) มาแล้ว

2.1 ให้ทดสอบเพื่อการตรวจรับในแต่ละหัวข้อ โดยพิจารณาจากจำนวนหม้อแปลงทั้งหมดในสัญญาในแต่ละรายการ (Item) ที่มีหมายเลขรหัสพัสดุเดียวกัน ตามตารางที่ 2 ดังนี้



การไฟฟ้าส่วนภูมิภาค
PROVINCIAL ELECTRICITY AUTHORITY

PROVINCIAL ELECTRICITY AUTHORITY

TECHNICAL SPECIFICATION DIVISION

THREE-PHASE TRANSFORMERS FOR 22 kV AND 33 kV 50 Hz DISTRIBUTION SYSTEMS WITH ABILITY TO WITHSTAND SHORT CIRCUIT

Specification No. RTRN-035/2561

Approved date: **04 NOV 2020**

Rev. No.: 0

Form No.

Page 2 of 2

ตารางที่ 2

จำนวนหม้อแปลงทั้งหมด ในสัญญา ⁽²⁾ (เครื่อง)	หัวข้อการทดสอบเพื่อการตรวจรับที่ต้องทดสอบ		
	Temperature-rise test	Full wave lightning impulse test	Short-circuit withstand test
0 ถึง 9	ไม่ทดสอบ	ไม่ทดสอบ	ไม่ทดสอบ
10 ถึง 29	ทดสอบ	ไม่ทดสอบ	ไม่ทดสอบ
30 ถึง 189	ทดสอบ	ทดสอบ	ไม่ทดสอบ
190 ขึ้นไป	ทดสอบ	ทดสอบ	ทดสอบ

⁽²⁾ จำนวนหม้อแปลงทั้งหมดในสัญญา แยกตามหมายเลขรหัสพัสดุ

2.2 ให้ทดสอบเพื่อการตรวจรับกับหม้อแปลงที่ส่งในงวดแรกของสัญญา โดยสุ่มตัวอย่างแต่ละรายการ (Item) ที่มีหมายเลขรหัสพัสดุเดียวกัน และใช้ตัวอย่างเดียวกันกับตัวอย่างที่ผ่านการทดสอบตามหัวข้อ 1e.5.1(1) ถึง (7) และหัวข้อที่ 1e.5.1(11) มาแล้ว เพื่อลดระยะเวลาการทดสอบ ให้สามารถแยกทดสอบในแต่ละหัวข้อโดยใช้หม้อแปลงตัวอย่างที่แตกต่างกันได้ เช่น หากทดสอบหัวข้อ 1e.5.1(8) (9) และ (10) ให้สามารถใช้ 3 ตัวอย่าง (3 Serial numbers) ได้ โดยเกณฑ์การพิจารณาให้เป็นไปตามตารางที่ 3 ดังนี้

ตารางที่ 3

หัวข้อการทดสอบตรวจรับ (1e.5.1)	จำนวนตัวอย่าง ที่ส่งทดสอบเพื่อการตรวจรับ (เครื่อง)	จำนวนตัวอย่างสูงสุด ที่ยอมรับให้ทดสอบไม่ผ่าน (เครื่อง)
(8) Temperature-rise test	1	0
(9) Full wave lightning impulse test	1	0
(10) Short-circuit withstand test	1	0

ทั้งนี้ หากจำนวนหม้อแปลงที่ไม่ผ่านการทดสอบมากกว่าจำนวนตัวอย่างสูงสุดที่ยอมรับให้ทดสอบไม่ผ่านตามตารางที่ 3 ให้คณะกรรมการตรวจรับพัสดุฯ ดำเนินการตามขั้นตอนการตรวจรับพัสดุฯ ในหลักเกณฑ์การตรวจรับพัสดุฯ กฟภ.

หลังจากการทดสอบในแต่ละหัวข้อ คู่สัญญาจะต้องทำให้หม้อแปลงที่นำไปเป็นตัวอย่างทุกตัว สมบูรณ์พร้อมใช้งานเหมือนเดิมก่อนส่งคืนให้กับ PEA โดยไม่คิดค่าใช้จ่าย

หมายเหตุ

กรณีที กฟภ. เป็นผู้ประมาณการจัดหาหม้อแปลงที่มีพิกัดกำลังไฟฟ้าสูงกว่า 250 kVA ให้ทดสอบเพื่อการตรวจรับตามหัวข้อ 1e.5.1(1) ถึง (6) เท่านั้น



การไฟฟ้าส่วนภูมิภาค
PROVINCIAL ELECTRICITY AUTHORITY

PROVINCIAL ELECTRICITY AUTHORITY

ELECTRICAL AND MECHANICAL DIVISION

THREE-PHASE TRANSFORMERS FOR 22 kV AND 33 kV 50 Hz DISTRIBUTION SYSTEMS WITH ABILITY TO WITHSTAND SHORT CIRCUIT

Specification No. RTRN-035/2561

Approved date: **04 NOV 2021**

Rev. No.: 0

Form No.

Page 1 of 1

เอกสารเพิ่มเติมแนบรายละเอียดสเปค 3 (ADDENDUM 3)

เอกสารเพิ่มเติมแนบรายละเอียดสเปค (ADDENDUM) นี้ให้ถือเป็นส่วนหนึ่งของสเปคหม้อแปลงไฟฟ้าระบบ
จำหน่ายเลขที่ RTRN-035/2561

รายละเอียดห้องปฏิบัติการทดสอบนี้ ให้ใช้แทนหัวข้อ 1e.3 Acknowledged independent testing
laboratories ในสเปค

1e.3 Acknowledged independent testing laboratories

The type test and short-circuit withstand test shall be conducted or inspected by the
acknowledged testing laboratories/institutes as follows:

- (1) Laboratories/institutes which are members of the Short-circuit Testing Liaison (STL) or
independent laboratories/institutes which are accredited according to TIS 17025 or
ISO/IEC 17025 with the scope of accreditation covered the relevant test items,
standards, and equipment.

The certification and scope of accreditation of the independent laboratories/institutes
shall be submitted with the bid for consideration.

The bidders or manufacturers who are accredited according to TIS 17025 or ISO/IEC
17025 preferring to carry out the type tests and short-circuit withstand test of the
transformers with the laboratories or by the manufacturers themselves, the tests shall
be inspected by Thailand's national laboratories, institutes, universities, and electric
utilities in (2) and other laboratories, institutes, universities, or electric utilities
approved by PEA.

- (2) Thailand's national laboratories, institutes, universities, and electric utilities, as follow:
 - Electricity Generating Authority of Thailand (EGAT)
 - Thonburi Electrical Power Laboratory (TEPL)
- (3) Other laboratories, institutes, universities, or electric utilities approved by PEA. In this
case, the detail of the test facilities of the laboratories shall be submitted to PEA for
approval before proceeding the tests and before the bid closing date. PEA reserves
the right to send representatives to inspect and witness the tests with the cost of the
bidders or manufacturers.





**THREE-PHASE TRANSFORMERS FOR 22 kV AND 33 kV 50 Hz DISTRIBUTION SYSTEMS
WITH ABILITY TO WITHSTAND SHORT CIRCUIT**

Specification No. RTRN-035/2561

Approved date : 30/05/2562

Rev. No. : 5

Form No. 02-3S

Page 1 of 32

Invitation to Bid No.:

C Material, equipment, and specifications for THREE-PHASE TRANSFORMERS FOR 22 kV AND 33 kV 50 Hz DISTRIBUTION SYSTEMS WITH ABILITY TO WITHSTAND SHORT CIRCUIT

C1 General material and packing instructions

Additional to the general instructions, the following shall be observed:

1a Scope

These specifications cover three-phase transformers, oil-immersed, natural self-cooled, power range from 50 kVA to 2,000 kVA, designed and constructed to withstand without damage the thermal and dynamic effects of external short circuits, suitable for outdoor installation on 22 kV and 33 kV 50 Hz distribution systems.

1b Standards

The transformers shall be manufactured and tested in accordance with the following standards:

Thailand Industrial Standard (TIS)

TIS 384: 2543 Power Transformers

International Electrotechnical Commission (IEC)

IEC 60076-1:2011 Power transformers– Part 1: General

IEC 60076-2:2011 Power transformers – Part 2: Temperature rise for liquid-immersed transformers

IEC 60076-3:2013 Power transformers – Part 3: Insulation levels, dielectric tests and external clearances in air

IEC 60076-5:2006 Power transformers – Part 5: Ability to withstand short circuit

IEC 60296: 2012 Fluids for electrotechnical applications – Unused mineral insulating oils for transformers and switchgear

International Organization for Standardization

ISO 12944-5:2007 Paints and varnishes - Corrosion protection of steel structures by protective paint systems - Part 5: Protective paint systems

LV bushings shall be in accordance with the DIN 42530. HV bushings shall be in accordance with the DIN 42531.

And all other relevant standards, unless otherwise specified in these specifications.

PEA will also accept the transformers and accessories tested in accordance with the later edition of the above standards.



**THREE-PHASE TRANSFORMERS FOR 22 kV AND 33 kV 50 Hz DISTRIBUTION SYSTEMS
WITH ABILITY TO WITHSTAND SHORT CIRCUIT**

Specification No. RTRN-035/2561

Approved date : 30/05/2562

Rev. No. : 5

Form No. 02-3S

Page 2 of 32

PEA will also accept the type test report in accordance with the previous edition of the above standards, if there is no significant change in any test items or no additional test item(s) compared with the above standards. On the other hand, if there is significant change in any test items or there are any additional test items, the previous edition type test report with the additional test report(s) of the significant change test item(s) and/or additional test item(s) will be also accepted.

1c Principal requirement

1c.1 Service conditions and installation

The transformers shall be designed and constructed for outdoor installation and operation under the following conditions:

Altitude	:	up to 1,000 m above sea level
Ambient air temperature	:	50°C, maximum
	:	40°C, monthly average, of the hottest month
Relative humidity	:	up to 94 %
Climate condition	:	tropical climate

Table 1 Transformer installation

Transformer Rating (kVA)	Installation
50 – 250	on concrete pole and on platform
315 – 1,500	on platform and on concrete foundation
2,000	on concrete foundation

1c.2 Oil preservation system

The transformers of **50 kVA to 500 kVA** shall be permanently sealed and completely oil filled system (without gas cushion) type (usually corrugated tank). The transformer tank cover shall be bolt tightened to the tank with suitable gasket sealing.

The transformers of **630 kVA to 2,000 kVA** shall be conservator system type.

1c.3 Rating

1. Rated power

The rated power, on continuous operation, for transformers shall be as follows:

50 kVA	250 kVA	500 kVA	1,000 kVA	2,000 kVA
100 kVA	315 kVA	630 kVA	1,250 kVA	
160 kVA	400 kVA	800 kVA	1,500 kVA	



**THREE-PHASE TRANSFORMERS FOR 22 kV AND 33 kV 50 Hz DISTRIBUTION SYSTEMS
WITH ABILITY TO WITHSTAND SHORT CIRCUIT**

Specification No. RTRN-035/2561

Approved date : 30/05/2562

Rev. No. : 5

Form No. 02-3S

Page 3 of 32

2. Rated voltages

The rated voltage of windings is given in **Table 2**.

Table 2 Rated voltage

Rated Primary Voltage	Rated Secondary Voltage
22 kV, 33 kV	416/240 V

3. Rated frequency: 50 Hz

1c.4 Core and windings

The cores and windings of transformers shall be as follows:

Table 3 Core and windings

Transformer Rating (kVA)	Construction of Core	HV and LV Windings shall be made of	Construction of Windings	
			HV winding	LV winding
50-2,000	According to manufacturer's standard	copper only	According to manufacturer's standard	According to manufacturer's standard

1c.5 Tappings

The primary windings of transformers shall be provided with full capacity of externally-operated off-circuit tap changers.

Tapping range: $\pm 2 \times 2.5\%$ of rated primary voltage

The externally-operated off-circuit tap changer shall be designed for de-energized operation with the operating handle brought out through the cover of the tank. The operating handle shall have provision for locking and shall give visual indication of the tapping position without unlocking.

The tap changer shall have a locking device to prevent improper use. The operating handle shall be rotated in clockwise direction from a high tap voltage to a lower tap voltage. The tap changer shall be provided with stops to identify the highest and lowest tap position. The tap changer positions shall be identified by the numbers in sequence. The number "1" shall be designated to the highest tap voltage. Consequently the number "5" indicates the lowest tap voltage. These identifications shall be in perfect correspondence to those indicated in the connection diagram on the nameplate. All five positions of the tap changer shall be operative positions.

The tap positions shall be indelibly marked with weather-proof paint and in a color which shall present distinctive contrast to the surrounding material.

The operating handle of tap changer shall be made from non-corrosion metal. Plastic is not acceptable.



**THREE-PHASE TRANSFORMERS FOR 22 kV AND 33 kV 50 Hz DISTRIBUTION SYSTEMS
WITH ABILITY TO WITHSTAND SHORT CIRCUIT**

Specification No. RTRN-035/2561

Approved date : 30/05/2562

Rev. No. : 5

Form No. 02-3S

Page 4 of 32

1c.6 Connection symbol

50 kVA to 2,000 kVA transformers shall have connection symbol Dyn 11.

1c.7 Losses and Short - circuit impedance

The specified or guaranteed losses plus positive tolerance, for each transformer unit shall not be more than the losses are shown in the **Table 4**.

Short-circuit impedance shall be measured on the principle tapping of 22 or 33 kV at ambient temperature then corrected to 75°C.

Short-circuit impedance of the offered transformers shall be as specified in the **Table 4** and have tolerance within $\pm 10\%$ except for transformer rating 500 kVA, the short-circuit impedance at 75°C of transformer rating 500 kVA shall be 6.5 or more.

Table 4 Losses and short circuit impedance

Transformer Rating (kVA)	Watt Loss (W)			Short-circuit Impedance at 75°C (%)
	No-load loss, for system voltage of :		Load loss at 75°C	
	22 kV	33 kV		
50	110	170	875	4
100	180	260	1450	4
160	260	370	2000	4
250	360	520	2750	4
315	440	630	3250	4
400	520	750	3850	4
500	610	900	4600	6.5 or more
630	680	1050	5600	6
800	800	1150	7000	6
1,000	940	1300	9000	6
1,250	1150	1530	11000	6
1,500	1380	1850	13200	6
2,000	1800	2140	18000	6

1c.8 Limits of temperature-rise, above 50°C ambient temperature

Of top oil : not exceeding 50 K

Of winding : not exceeding 55 K



**THREE-PHASE TRANSFORMERS FOR 22 kV AND 33 kV 50 Hz DISTRIBUTION SYSTEMS
WITH ABILITY TO WITHSTAND SHORT CIRCUIT**

Specification No. RTRN-035/2561

Approved date : 30/05/2562

Rev. No. : 5

Form No. 02-3S

Page 5 of 32

1c.9 Insulation level

The insulation level of HV windings, LV windings and connected parts of transformers shall be as specified in the **Table 5**:

Table 5 Insulation level

Nominal System Voltage (kV, r.m.s.)	Insulation Level	
	Impulse Test Voltage Full-wave (kV, peak)	Power Frequency Test Voltage, 1-min (kV, r.m.s.)
22	125	50
33	170	70
0.416/0.24	30	10

1c.10 Bushings

1. Number and location

Each transformer shall have three (3) high-voltage bushings and four (4) low-voltage bushings located on the cover of the tank.

Secondary neutral point of transformer shall be brought out by separate-insulated bushing(s) and loaded with rated current.

The HV bushings shall not be completed with the arcing horns.

2. Material

Transformer bushings shall be made of good commercial-grade wet-process porcelain.

The entire porcelain surface of the bushings that will be exposed after assembly shall be glazed.

The color of the glaze shall be brown.

3. Electrical characteristics

Transformer bushings shall be capable of withstanding the impulse and low-frequency voltage specified in the **Table 6**:

Table 6 Electrical characteristics

Bushing	Impulse Full Wave (kV, peak)	Low-frequency, 50 Hz (kV, r.m.s.)	
		Dry 1-minute	Wet 10-second
High-voltage bushings for 22 kV system	125	50	50
High-voltage bushings for 33 kV system	170	70	70
Low-voltage bushings	30	10	10



**THREE-PHASE TRANSFORMERS FOR 22 kV AND 33 kV 50 Hz DISTRIBUTION SYSTEMS
WITH ABILITY TO WITHSTAND SHORT CIRCUIT**

Specification No. RTRN-035/2561

Approved date : 30/05/2562

Rev. No. : 5

Form No. 02-3S

Page 6 of 32

4. Minimum Clearance

Safety clearance of Transformer bushings shall comply with minimum Clearance Criterion, which measurement between live part to live part or live part to ground shall be as follows.

- At least 225 mm for 22 kV System
- At least 320 mm for 33 kV System

5. Test report

The bidders have to submit the test report of bushing with the bid in order to confirm the electrical characteristic in **Table 6 Electrical characteristics**, the bidders who cannot submit will be rejected. The test of bushing can be conducted by manufacturer or third party laboratories.

1c.11 Terminal connectors

HV bushings shall be equipped with solderless clamp type connectors for aluminium conductor diameter range from 7.5 mm to 12.6 mm (sizes 35-95 mm²).

Only for 50 kVA to 1,250 kVA transformers: LV bushings shall be equipped with terminal pad connectors (stud type connectors are preferable), of high conductivity bronze and hot-tin dipped. The terminal pads shall be drilled in accordance with NEMA Standards (9/16" holes on 1 3/4" centers); each hole shall be furnished with one (1) bolt M12 x 60 mm (of at least 50 mm thread length), one (1) nut, two (2) flat washers, and one (1) lock washer; details of terminal pads shall be according to Drawing No. SA4-015/47002. The connectors shall be provided with mounting hardware (bolts, nuts, washers, and lock washers) of stainless steel or better.

Only for 1,500 kVA to 2,000 kVA transformers: LV bushings shall be equipped with solderless clamp type connectors (stud type connectors are preferable), of high conductivity bronze and hot-tin dipped, for aluminium and copper conductor sizes, and number of circuits take off shall be as **Table 7:**

Table 7 Terminal connectors for 1,500 kVA to 2,000 kVA transformers

Transformer Rating (kVA)	Applicable to Aluminium and Copper Conductors		Number of Circuits
	diameter range (mm)	sizes (mm ²)	
1,500	18.4 - 29.2	240 - 500	4
2,000	18.4 - 29.2	240 - 500	6

The connectors shall be provided with mounting hardware (bolts, nuts, washers, and lock washers) of stainless steel or better. The details of connectors shall be according to Drawing No. SA4-015/47002.



**THREE-PHASE TRANSFORMERS FOR 22 kV AND 33 kV 50 Hz DISTRIBUTION SYSTEMS
WITH ABILITY TO WITHSTAND SHORT CIRCUIT**

Specification No. RTRN-035/2561

Approved date : 30/05/2562

Rev. No. : 5

Form No. 02-3S

Page 7 of 32

1c.12 Tank and Tank finish

Tank and cover shall be constructed of welded steel plate suitable reinforced. The joints between the tank and cover shall be provided with suitable flanges properly bolted together with gaskets.

Tank cover shall have 90° downward bent edges on all sides to protect the gasket under the top cover from direct exposure to weather.

Gaskets between metal surfaces shall be set in grooves or held in position by retainers so arranged that all parts are bolted metal-to-metal. The gaskets shall be made of resilient material which will not deteriorate under the action of hot oil and will remain oil-tight. Gaskets of such material which can be easily damaged by overpressing are not acceptable.

The transformer tank shall be finished with mounting bracket for surge arrester (Surge arrester polymer housing type supplied by PEA) and shall be furnished with three (3) earthing terminal provided for ground leads of surge arrester, see Drawing No. SA4-015/50008.

The bidders have to give the transformer's tank dimensions which passed type test in **2a Performance data and guarantee of three-phase transformer (Page 29 of 32)**.

Tolerance of the transformer's tank dimensions for the purposed transformer shall be within ± 3 percent of the declared dimensions which given by the bidders in above information, Otherwise shall be rejected.

The distance between tank cover (Top plate) and fins which is installed the earthing terminal for surge arrester shall not less than 200 mm.

The manufacturer's serial number shall be dented on transformer tank cover.

The manufacture shall prepare 3 mm diameter holes for security seals threading. The first position, the hole shall be drilled at the right last bolt which fix tank and cover of transformer and the second position, the hole shall be drilled at the top right of transformer nameplate as **Figure 1**.

The security seals will be installed by PEA after any transformers pass the witness test or acceptance test or others depend on PEA's committee.

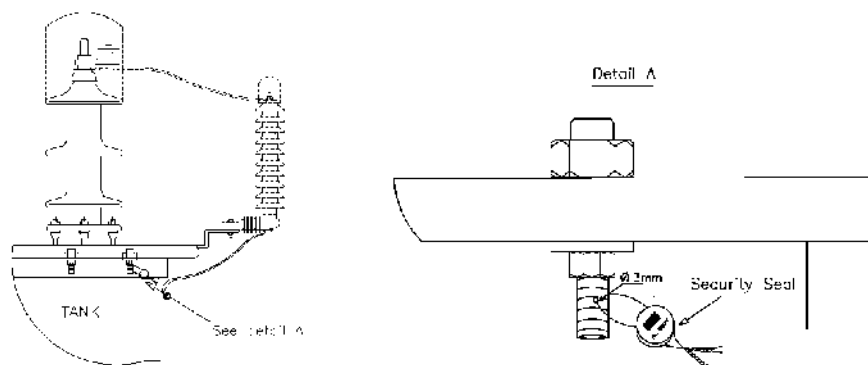



**THREE-PHASE TRANSFORMERS FOR 22 kV AND 33 kV 50 Hz DISTRIBUTION SYSTEMS
WITH ABILITY TO WITHSTAND SHORT CIRCUIT**

Specification No. RTRN-035/2561

Approved date : 30/05/2562

Rev. No. : 5

Form No. 02-3S

Page 8 of 32

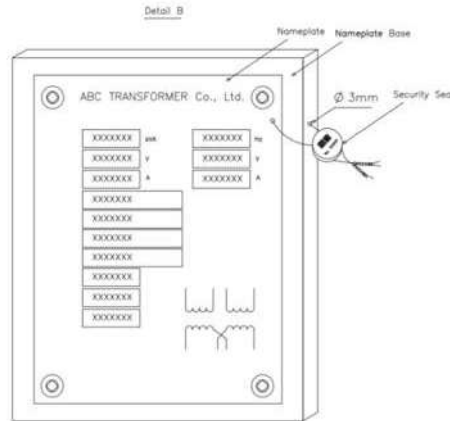

Note : The hole shall be drilled by manufacturer and thread with security seal by PEA

Figure 1 Security seal installation

1c.12.1 Painting system

1. Interior surface

Interior surface shall be finished oil resistant paint or vanish.

2. Exterior surface

The painting system will be suitable for an exterior servicing at medium atmospheric-corrosivity category is as C3, and system number is as A.3.08 in accordance with ISO 12944-5 Table A.3.

The coating system shall be in accordance with the ISO 12944-5 as following:

- Primer coat: The number of coats is one (1) or two (2) coats of Epoxy (Misc) Anti-Corrosive Primer, the dry film thickness shall not less than 80 µm.
- Subsequent coat(s): The number of coats is two (2) to three (3) of Epoxy Intermediate and Polyurethane topcoat with RAL 7036 gray color.
- The total number of coats is two (2) to four (4) coats and the dry film thickness of coating system shall not less than 160 µm.

3. Dry film thickness test and test report

The dry film thickness shall be spot checked for each layer of coating. The position of spot checks is specified as **Figure 2** for transformers of permanently sealed type, and **Figure 3** for transformers of conservator system type.



**THREE-PHASE TRANSFORMERS FOR 22 kV AND 33 kV 50 Hz DISTRIBUTION SYSTEMS
WITH ABILITY TO WITHSTAND SHORT CIRCUIT**

Specification No. RTRN-035/2561

Approved date : 30/05/2562

Rev. No. : 5

Form No. 02-3S

Page 9 of 32

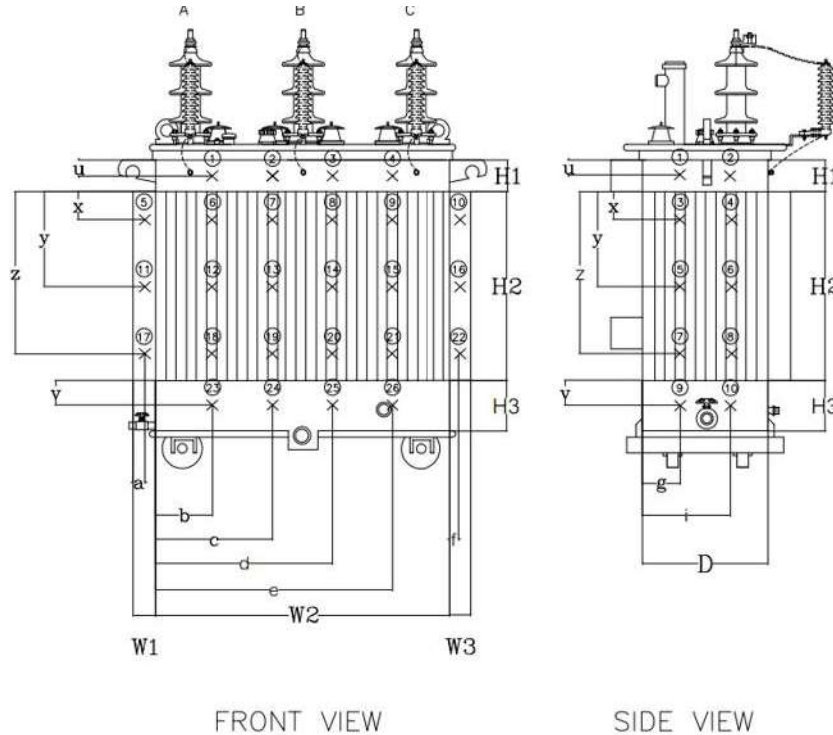

Figure 2 The position of spot checking for transformers of permanently sealed type.

The distance for spot checking of permanently sealed type is as **Table 8**:

Table 8 Distance for spot checking of permanently sealed type

Symbols	Length	Symbols	Length
a	About 1/2 of width (W1)	u	About 1/2 of height (H1)
b	About 1/5 of width (W2)	v	About 1/2 of height (H3)
c	About 2/5 of width (W2)	x	About 1/4 of height (H2)
d	About 3/5 of width (W2)	y	About 2/4 of height (H2)
e	About 4/5 of width (W2)	z	About 3/4 of height (H2)
f	About 1/2 of width (W3)		
g	About 1/3 of depth (D)		
i	About 2/3 of depth (D)		



**THREE-PHASE TRANSFORMERS FOR 22 kV AND 33 kV 50 Hz DISTRIBUTION SYSTEMS
WITH ABILITY TO WITHSTAND SHORT CIRCUIT**

Specification No. RTRN-035/2561

Approved date : 30/05/2562

Rev. No. : 5

Form No. 02-3S

Page 10 of 32

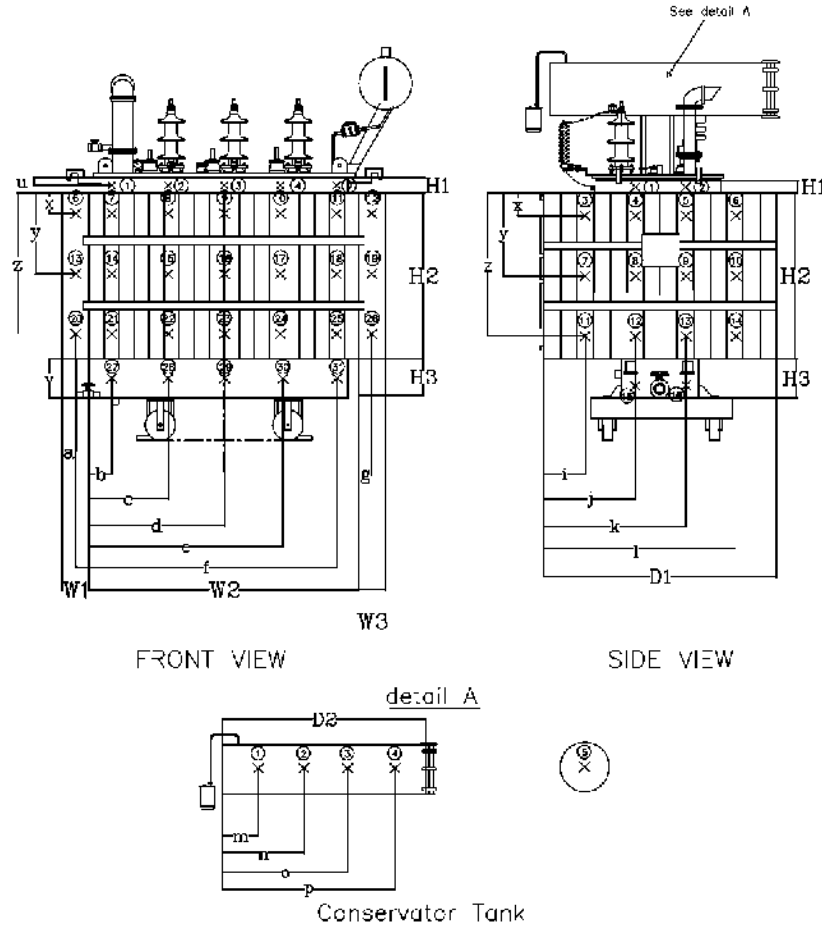

Figure 3 The position for spot checking for transformers of conservator system type.

The distance for spot checking of conservator system type is as **Table 9:**

Table 9 Distance for spot checking of conservator system type

Symbols	Length	Symbols	Length
a	About 1/2 of height (W1)	m	About 1/5 of depth (D2)
b	About 1/6 of height (W2)	n	About 2/5 of depth (D2)
c	About 2/6 of height (W2)	o	About 3/5 of depth (D2)
d	About 3/6 of height (W2)	p	About 4/5 of depth (D2)
e	About 4/6 of height (W2)	u	About 1/2 of height (H1)
f	About 5/6 of height (W2)	v	About 1/4 of width (H3)
g	About 1/2 of height (W3)	x	About 1/4 of width (H2)
i	About 1/5 of depth (D1)	y	About 2/4 of width (H2)
j	About 2/5 of depth (D1)	z	About 3/4 of width (H2)
k	About 3/5 of depth (D1)		
l	About 4/5 of depth (D1)		



**THREE-PHASE TRANSFORMERS FOR 22 kV AND 33 kV 50 Hz DISTRIBUTION SYSTEMS
WITH ABILITY TO WITHSTAND SHORT CIRCUIT**

Specification No. RTRN-035/2561

Approved date : 30/05/2562

Rev. No. : 5

Form No. 02-3S

Page 11 of 32

The bidders have to submit the test report, conducted by the acknowledged testing laboratories or manufacture, with the bid. The Item offered without submitting the dry film thickness test report shall be rejected.

The cost of all tests and reports shall be borne by the bidders/manufacturers/contractor.

1c.12.2 Dry film thickness test report

The required information in dry film thickness test report shall be at least the following items:

- (1) Transformer information
 - 1) Manufacturer's name
 - 2) Model
 - 3) Serial number
 - 4) Number of phase
 - 5) Rated voltage of the high-voltage winding
 - 6) Rated voltage of the low-voltage winding
 - 7) Rated frequency
 - 8) Rated power
 - 9) Rated current of the high-voltage winding
 - 10) Rated current of the low-voltage winding
- (2) Painted information
 - 1) Coating system (flow coating or spraying)
 - 2) The information for each coating (Primer coat, Subsequent coat, Top coat) minimum as following:
 - Type of material
 - Paint Manufacturer
 - Require minimum dry film thickness (μm) as specified
 - Actual dry film thickness (μm) (3 reading per 1 spot checks)
 - 3) Technical Data of coats
 - 4) Painting Procedure

1c.12.3 Acceptance test procedure of dry film thickness test

The total dry film thickness of coating shall be measured by contractor for acceptance testing and witness by the PEA's acceptance committee. Total dry film thickness shall be not less than 160 μm according to ISO 12944-5. PEA will randomly select the samples of transformer only from the first lot. The number of samples and criteria for consideration shall be according to **Table 10**.

PEA reserve the right to send representative to inspect and witness test.

The cost of all tests and reports shall be borne by the manufacturers/contractor.



**THREE-PHASE TRANSFORMERS FOR 22 kV AND 33 kV 50 Hz DISTRIBUTION SYSTEMS
WITH ABILITY TO WITHSTAND SHORT CIRCUIT**

Specification No. RTRN-035/2561

Approved date : 30/05/2562

Rev. No. : 5

Form No. 02-3S

Page 12 of 32

1c.13 Marking

PEA's code number and word "**SHORT CIRCUIT WITHSTAND**" shall be painted, in orange, on the transformer tank (for transformer having no conservator) or on the conservator tank (for transformer having conservator) at the position that enables a clear observation, and also be legibly and durably inscribed on the metal part of nameplate. The code number and dimensions of each letter to be marked shall be given by PEA after the final of bid consideration.

1c.14 Accessories

The 50 kVA to 2,000 kVA transformers shall be furnished and equipped with the following accessories:

1. HV and LV bushings, with terminal connectors
2. Bird guard cap (bushing cover), ultra-violet and track resistant material, e.g. polypropylene, neoprene, etc; which is suitable for exposure to sunlight
3. Earthing terminal for surge arrester, with solderless clamp type connector suitable for flexible copper insulated ground lead size 16 mm², 430 mm long. (See Drawing No. SA4-015/50008)
4. Tap changer
5. Thermometer pocket, transformers shall have a thermometer pocket to allow the measuring of the top-oil temperature. This pocket shall be placed as shown in the EN 50216-4 (type A1). The pocket shall be provided with a corrosion-proof cap. The thread shall be protected with silicone-grease. Dimensions of the thermometer pocket in mm are shown as **Figure 4**.

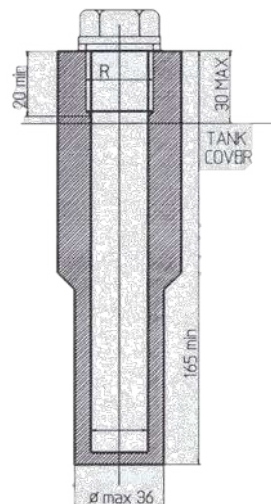

Figure 4 Dimensions of thermometer pockets

6. Nameplate with connection diagram
7. Oil drain valve with plug or cap, installed at the lower part of the tank
8. Sludge drain plug, installed at the bottom of the tank



PROVINCIAL ELECTRICITY AUTHORITY

TECHNICAL SPECIFICATION DIVISION

THREE-PHASE TRANSFORMERS FOR 22 kV AND 33 kV 50 Hz DISTRIBUTION SYSTEMS WITH ABILITY TO WITHSTAND SHORT CIRCUIT

Specification No. RTRN-035/2561

Approved date : 30/05/2562

Rev. No. : 5

Form No. 02-3S

Page 13 of 32

9. Earthing terminal, with solderless clamp type connector suitable for steel stranded conductor diameter of 9.0 mm (size 50 mm²); complete with lockwasher of stainless steel or better.
10. Lifting lugs
11. Lifting eyes on the cover
12. Oil level gauge
13. Compression type cable lug, for aluminium conductor diameter of 7.5-9.0 mm (sizes 35-50 mm²), suitable for connecting between HV bushing and surge arrester lead conductor.
14. Only for 50 kVA to 250 kVA transformers: Pressure relief valve on the tank cover, oil filling plug on the tank cover, and supporting lugs for hanging the transformer tank to pole by using two (2) M16 machine bolts.
The lugs shall have 600 mm spacing; 500 mm or 400 mm spacing may be used when tank height will not permit the 600 mm dimension. (See Drawing No. SA4-015/50008)
Only for 315 to 500 kVA transformers: Pressure relief valve on the tank cover, and oil filling plug on the tank cover.
Only for 630 kVA to 2,000 kVA transformers: Pressure relief valve on the tank cover, oil conservator with dehydrating breather and oil level gauge. The cylinder of dehydrating breather shall be of transparent glass. The dehydrating breather shall be easy replaced and filled with silica-gel not less than 1.0 kg.
15. Only for 315 kVA to 2,000 kVA transformers: Transport rollers
16. Only for 1,000 kVA to 2,000 kVA transformers:
 - (a) Dial type thermometer with adjustable contact(s)
 - (b) Double float Buchholz relay having two (2) contacts (for alarm and tripping)
17. Other necessary accessories according to manufacturer's design.

1c.15 Initial oil filling

The transformers shall be supplied with initial oil filling. The oil shall be according to IEC 60296, high-quality, clean and dry.

The oil shall be free from Polychlorinated biphenyls (PCB).

1c.16 Nameplate

The following minimum nameplate information shall be legibly and durably inscribed on the metal part of nameplate:

- (1) Manufacturer's name
- (2) Manufacturer's serial number
- (3) Year of manufacture
- (4) PEA's code number



**THREE-PHASE TRANSFORMERS FOR 22 kV AND 33 kV 50 Hz DISTRIBUTION SYSTEMS
WITH ABILITY TO WITHSTAND SHORT CIRCUIT**

Specification No. RTRN-035/2561

Approved date : 30/05/2562

Rev. No. : 5

Form No. 02-3S

Page 14 of 32

- (5) Contract number and/or PO number
- (6) Number of phases
- (7) Rated frequency in Hz
- (8) Rated power in kVA
- (9) Rated voltage in V
- (10) Rated current in A
- (11) Rated secondary short-circuit withstand current in kA r.m.s.
- (12) Tapping voltages in V
- (13) Connection symbol
- (14) Short-circuit impedance in %
- (15) Connection diagram
- (16) Type of cooling
- (17) Oil quantity in liters
- (18) Drain oil quantity in liters (for permanently sealed type)
- (19) Total weight in kg
- (20) Wording “**SHORT CIRCUIT WITHSTAND**”
- (21) Material of HV and LV winding such as copper winding, cooper foil etc.

1c.17 Bushing location and terminal markings

Bushing shall locate as shown in the figures below:

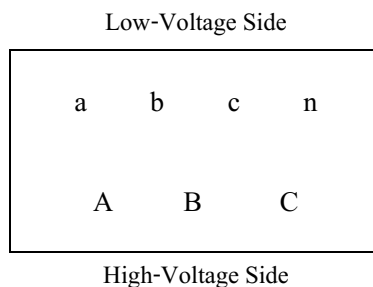

Figure 5 50-250 kVA Tank top view

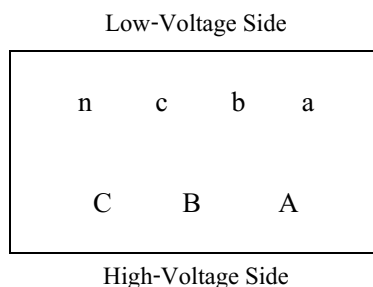

Figure 6 315 -2,000 kVA Tank top view



**THREE-PHASE TRANSFORMERS FOR 22 kV AND 33 kV 50 Hz DISTRIBUTION SYSTEMS
WITH ABILITY TO WITHSTAND SHORT CIRCUIT**

Specification No. RTRN-035/2561

Approved date : 30/05/2562

Rev. No. : 5

Form No. 02-3S

Page 15 of 32

The letters A, B, C, a, b, c, and n shall be durable marked on transformer tank beside bushings consequently. The height of the symbols shall not less than 30 mm.

Mark by sticker is not accepted.

1c.18 Mass

For 50 kVA to 160 kVA transformers: Mass of complete transformer with oil and accessories shall not be more than 1,000 kg.

For 250 kVA transformers: Mass of complete transformer with oil and accessories shall not be more than 1,200 kg.

Tolerance of the mass of proposed complete transformers with oil shall be within ± 5 percent of the declared mass of transformer which passed type test given by the bidders in 2a Performance data and guarantee of three-phase transformer (Page 28 of 32) but the maximum mass shall not exceed the above allowable mass.

If the mass of complete transformers with oil more than ± 5 percent of the declared mass or exceed the above allowable mass, the transformers shall be rejected.

1d Packing

For transformers manufactured outside the territories of Thailand, each transformer shall be seaworthy packed in individual export crate or wooden case which will not be returned.

For transformers manufactured within the territories of Thailand, each transformer shall be packed in individual crate or wooden case which will not be returned.

Only for 50 kVA to 160 kVA transformers for 22 kV systems and 50 kVA to 100 kVA transformers for 33 kV systems, each crate or wooden case shall be strong enough for stacking over with at least another one.

If the crate or wooden case is made of rubber wood (Yang-para), the wooden parts shall be treated with wood preservative.

The details of wood treatment shall be described.

1e Tests and test reports

1e.1 Routine test

Each transformer shall pass the manufacturer's standard routine tests, and also pass the following tests in accordance with the relevant standards:

- (1) Measurement of winding resistance (IEC 60076-1)
- (2) Measurement of voltage ratio and check of phase displacement (IEC 60076-1)
- (3) Measurement of short-circuit impedance and load loss (IEC 60076-1)
- (4) Measurement of no-load loss and current (IEC 60076-1)



**THREE-PHASE TRANSFORMERS FOR 22 kV AND 33 kV 50 Hz DISTRIBUTION SYSTEMS
WITH ABILITY TO WITHSTAND SHORT CIRCUIT**

Specification No. RTRN-035/2561

Approved date : 30/05/2562

Rev. No. : 5

Form No. 02-3S

Page 16 of 32

- (5) Applied voltage test (IEC 60076-1 and IEC60076-3)
- (6) Induced voltage withstand test (IEC 60076-1 and IEC60076-3)

The Item offered without submitting the list of routine test report shall be rejected.

1e.2 Type test and Short-circuit withstand test

For transformers rating of 50 kVA to 250 kVA and the reference transformers

For transformers rating of 50 kVA to 250 kVA and the reference transformers, these transformers shall be passed all items of type test and short circuit withstand test according to **1e.2.2 Test procedure of Type test and Short-circuit withstand test**. The test result shall be included in one (1) test report. The test report shall be issued or approved by the same acknowledged independent testing laboratory according to **1e.3 Acknowledged independent testing laboratories**, otherwise will be rejected.

For the others rating which are not the reference transformers

The transformers shall be passed the following type tests in accordance with the relevant standards:

- (1) Temperature-rise test (IEC 60076-2)
- (2) Full wave lightning impulse test (IEC 60076-1 and IEC 60076-3)
- (3) Measurement of no-load loss and current at 90 % and 110 % of rated voltage (IEC 60076-1)

Type test shall be made on only one (1) unit of each rating. The test result shall be included in one (1) test report. The test report shall be issued or approved by the same acknowledged independent testing laboratory according to **1e.3 Acknowledged independent testing laboratories**, otherwise will be rejected.

1e.2.1 Short-circuit withstand test

The transformers shall be designed and constructed to withstand without damage by the thermal and dynamic effects of the external short circuit in accordance with the IEC 60076-5.

The duration of the current I to be used for the calculation of the thermal ability to withstand short circuit shall be 2 s and the initial temperature for calculation shall be 105°C.

Test procedure of short-circuit withstand test shall be according to **1e.2.2 Test procedure of Type test and Short-circuit withstand test**.

The total number of tests shall be nine made in a different position of the tap-changer according to IEC 60076-5. The duration of each test shall be 0.5 s