

Invitation to Bid No.:

C Material, equipment, and specifications for ELECTRONIC ENERGY METERS

C1 General material and packing instructions

In addition to the general instructions, the following shall be observed:

1a Scope

These specifications cover electronic energy meters used in PEA's system for measuring and recording electrical energy for billing, measuring and recording other electrical quantities completed with their functions and accessories.

1b Standards

The electronic energy meters (hereinafter called the meters) shall be manufactured and tested in accordance with the following standards:

Thailand Industrial Standard (TIS)

- | | |
|---------------|---|
| TIS 1030-2552 | Electricity metering equipment (a.c.) – General requirements, tests and test conditions |
| TIS 2543-2555 | Electricity metering equipment (a.c.) – Particular requirements – Static meters for active energy (classes 1 and 2) |
| TIS 2544-2555 | Electricity metering equipment (a.c.) – Particular requirements – Static meters for active energy (classes 0.2S and 0.5S) |

International Electrotechnical Commission (IEC)

- | | |
|--------------------|--|
| IEC 62052-11: 2003 | Electricity metering equipment (a.c.) – General requirements, tests and test conditions – Part 11: Metering equipment |
| IEC 62053-21: 2003 | Electricity metering equipment (a.c.) – Particular requirements – Part 21: Static meters for active energy (classes 1 and 2) |
| IEC 62053-22: 2003 | Electricity metering equipment (a.c.) – Particular requirements – Part 22: Static meters for active energy (classes 0.2S and 0.5S) |
| IEC 62053-23: 2003 | Electricity metering equipment (a.c.) – Particular requirements – Part 23: Static meters for reactive energy (classes 2 and 3) |

And all other relevant standards, unless otherwise specified in these specification.

PEA will also accept the meters tested in accordance with the later edition of the above standards.

PEA will also accept the type test report in accordance with the previous edition of the above standards, if there is no significant change in any test items or no additional test item(s) compared with the above standards. On the other hand, if there is significant change in any test items or there are any additional test items, the previous edition type test report with the additional test report(s) of the significant change test item(s) and/or additional test item(s) will be also accepted.

1c Principal requirement

1c.1 Service conditions and installation

The meters shall be weatherproof and dustproof designed and constructed for **outdoor installation** on concrete poles without additional protection for operation under the following conditions:

- Altitude : up to 1,000 m above sea level
- Ambient air temperature : up to 55 °C
- Average relative humidity in any one year : up to 95 %
- Climatic condition : tropical climate

1c.2 Ratings and characteristics

The minimum requirement of ratings and characteristics of the meters shall be according to **Table 1: Ratings and characteristics of the meters.**

Table 1

Ratings and characteristics of the meters

Ratings and characteristics	unit	Requirements ¹⁾	
		1-phase meters	3-phase 4-wire meters
Operating voltage	V AC	230 ± 10 %	230/400 ± 10 %
Current rating ²⁾			
- for direct connected meters, $I_b(I_{max})$	A	5(100)	5(100)
- for CT operated meters, $I_n(I_{max})$	A	-	5(6)
Reference frequency	Hz	50	
Accuracy class			
- Active energy			
- for direct connected meters	-	1	1
- for CT operated meters	-	-	0.5S
- Reactive energy	-	2	2
Protective class	-	II	
Degree of protection	-	IP 54	
Maximum operating temperature	°C	up to 70	

Note: ¹⁾ Requirements for each item of the electronic energy meters are specified in “C3 Schedule of detailed requirement”

²⁾ PEA will also accept electronic energy meters having basic current rating (I_b) less than the basic current rating specified in the Table above and/or maximum current rating (I_{max}) more than the maximum current rating specified in the Table above.

1c.3 Constructional requirements

The meters shall have constructional requirements as follows:

1c.3.1 Mounting

The meters shall be arranged for three-point mounting. The permanent seal box complete with three-point mounting will be also accepted. Mounting holes shall accommodate 5.0 mm mounting screws. The upper mounting hole should be external to the body; and the two (2) lower mounting holes shall be on both sides of the meter-base bottom part which is holding terminal block, and the two (2) lower mounting holes shall be within the area of the perpendicular projection of the terminal cover.

1c.3.2 Meter base

Meter base shall be made of UV-resistance, high impact-resistance and self-extinguishing polycarbonate. Color of the meter base is preferably grey.

1c.3.3 Meter cover

The meter cover shall be made of UV-resistance, high impact-resistance and self-extinguishing polycarbonate. The meter cover shall be permanent seal.

1c.3.4 Terminals and terminal block

The terminals shall be made of high-conductivity solid brass and terminal screws shall be made of solid brass or steel with nickel plated or tin plated and suitable for using with aluminium and copper insulated cables having dimensions according to **Table 2: Dimensions of cables used with the meters**. Each terminal shall have two (2) fixing screws.

Manufacturer shall design the suitable terminals to protect screw loosening especially when the large conductor (50 sq.mm.) will be installed.

The terminals shall be the bottom-connected type and grouped in a terminal block.

The terminals and screws shall be designed to protect a deformation of the conductors (In case PEA has to change or replace the meters, the conductors shall be removed easily without deformation or damage) such as by using conductor supporting plates, when screwed on them. The design of the terminals and screws shall be described by the bidders.

Table 2

Dimensions of cables used with the meters

Current rating (A)		Cables ³⁾		
		Cross section area (mm ²)	Conductor diameter (mm)	Overall diameter (mm)
$I_n(I_{max})$	5(6)	2.5	2.2	4.5
$I_b(I_{max})$	5(100)	4 – 50	2.4 – 9.1	4.6 – 12.1

Note: ³⁾ Terminals and terminal block of the proposed meters shall be designed for using with whole range of the cable sizes as specified in the Table above.

1c.3.5 Terminal cover

The terminal cover shall be made of transparent, UV-resistance, high impact-resistance and self-extinguishing polycarbonate and suitable for cables incoming and outgoing vertically from the bottom, and shall have provision for security sealing.

The connection diagram of the meters shall be durable marked on the terminal cover.

1c.3.6 Nameplate

The inscription on nameplate shall be marked in English according to the relevant standard, and marked with three (3) additional marks as follows:

(1) SUPPLIED BY PROVINCIAL ELECTRICITY AUTHORITY

(2) PEA number : PEA XXXXXXXXXXXX

(XXXXXXXXXXXX is the number to be marked on the nameplate which shall be given by PEA after the final of bid consideration.)

(3) Barcode : (The barcode to be marked shall be the same as PEA number mentioned in Item (2). The barcode symbology shall be Code 128 according to ISO/IEC 15417)

The example of the nameplate is shown in **Figure 1**.

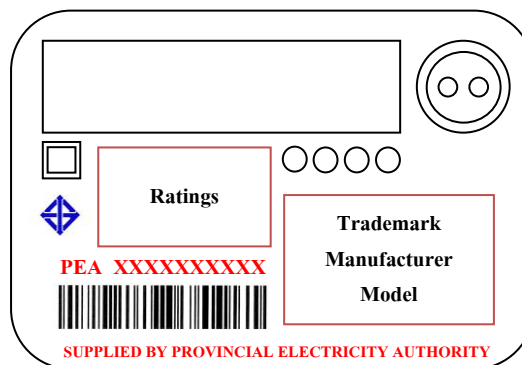

Figure 1: Example of meter's nameplate

The nameplate placed inside the meter cover or with a separate transparent cover for environment protection is preferable.

1c.3.7 Polycarbonate

The polycarbonate used for meter base, meter cover and terminal cover shall be high impact and UV resistant grade.

Information and properties of the polycarbonate shall be given by the bidder.

The contractor has to guarantee quality of the meter base, meter cover and terminal cover made of polycarbonate not less than ten (10) years.



1c.4 Measured values and register unit

1c.4.1 Measured values and register unit for 1-phase meters

Minimum requirements of quantities measured and displayed by the meters are shown as the followings:

- (1) Current date and time
- (2) Total kWh⁴⁾ (import, export, absolute⁵⁾ and net⁶⁾)
- (3) Maximum kW demand (import and export)
- (4) Instantaneous active power in kW
- (5) Instantaneous voltage in V r.m.s.
- (6) Instantaneous current in A r.m.s.
- (7) Instantaneous power factor or phase angle

Note: ⁴⁾ The values of Total kWh shall be programmable to display only one (1) of three (3) groups, by PEA staff, as follows:

- (1) Group 1 : Import and export kWh
- (2) Group 2 : Absolute kWh
- (3) Group 3 : Net kWh

⁵⁾ Absolute energy is the sum of absolute import and absolute export energy. The default setting of Total kWh shall be absolute values however can be able to program by PEA staff.

⁶⁾ Net energy is the difference between the import and export energy.

The display shall have symbols or indicators for indicating the operations of the meters, meter statuses, and also both import and export directions of measured values.

The register unit shall be solid-state microprocessor based register with internal memory of programmable and reprogrammable type. The internal memory shall be non-volatile semi-conductor type.

The display shall be at least 6-digit LCD display. The digits display of quantities measured and displayed shall be according to **Table 3: Digits display of the 1-phase meters.**

Table 3

Digits display of the 1-phase meters

Quantities measured and displayed	unit	Digits display
Total kWh	kWh	xxxxx.x kWh, or better
Active power	kW	xxx.xxx kW, or better
Voltage	V	xxxxx.x V, or better
Current	A	xxxx.xx A, or better
Power factor or phase angle	- ,or °	xxx.xxx or xxxx.xx °, or better
Current date	-	dd/mm/yy
Time	-	hh:mm

The minimum size of the LCD display shall be 8 cm^2 . The minimum height of each digit showing the measured quantities on LCD display shall be 8 mm.

The LCD display shall have the capability to operate under temperature up to 70°C .

The register unit shall have the following display operating modes:

- (1) Scrolling mode, shall be programmable the data such as kWh, Instantaneous active power and other measuring data will be shown on the display in sequence automatically. The scrolling time shall be programmable up to 15 seconds.
- (2) Manual mode, the push button or switch on the meter's panel shall be used for starting the display sequence and showing the various stored data.

1c.4.2 Measured values and register unit for 3-phase meters

Minimum requirements of quantities measured and displayed by the meters are shown as the followings:

- (1) Current date and time
- (2) Total kWh⁷⁾ (import, export, absolute⁸⁾ and net⁹⁾)
- (3) Total kvarh⁷⁾ (import, export, absolute⁸⁾ and net⁹⁾)
- (4) Maximum kW demand (import and export)
- (5) Cumulative kW demand (import and export)
- (6) Maximum kvar demand (import and export)
- (7) Cumulative kvar demand (import and export)
- (8) Instantaneous total active power in kW
- (9) Instantaneous total reactive power in kvar
- (10) Instantaneous per-phase voltage in V r.m.s.
- (11) Instantaneous per-phase current in A r.m.s.
- (12) Instantaneous per-phase power factor or phase angle

Note: ⁷⁾ The values of Total kWh and Total kvarh shall be programmable to display only one (1) of three (3) groups, by PEA staff, as follows:

- (1) Group 1 : Import and export kWh as well as Import and export kvarh
- (2) Group 2 : Absolute kWh and Absolute kvarh
- (3) Group 3 : Net kWh and Net kvarh

⁸⁾ Absolute energy is the sum of absolute import and absolute export energy. The default setting of Total kWh and Total kvarh shall be absolute values however can be able to program by PEA staff.

⁹⁾ Net energy is the difference between the import and export energy.

Each above quantity shall be displayed with at least three (3) digits identification code. The identification code shall be specified by PEA.

The display shall have symbols or indicators for indicating the operations of the meters, meter statuses, and also both import and export directions of measured values.

The register unit shall be solid-state microprocessor based register with internal memory of programmable and reprogrammable type. The internal memory shall be non-volatile semi-conductor type.

The display shall be at least 6-digit LCD display. The digits display of quantities measured and displayed shall be according to **Table 4: Digits display of the 3-phase meters.**

Table 4

Digits display of the 3-phase meters

Quantities measured and displayed	Unit	Digits display	
		3-phase 4-wire meters, direct connected	3-phase 4-wire meters, CT operated
Total kWh	kWh	xxxxx.x kWh, or better	xxxx.xx kWh, or better
Total kvarh	Kvarh	xxxxx.x kWh, or better	xxxx.xx kWh, or better
Active power	kW	xxx.xxx kW, or better	
Reactive power	Kvar	xxx.xxx kW, or better	
Voltage	V	xxxxx.x V, or better	
Current	A	xxxx.xx A, or better	
Power factor or phase angle	- ,or °	xxx.xxx or xxxx.xx °, or better	
Current date	-	dd/mm/yy	
Time	-	hh:mm	

The minimum size of the LCD display shall be 10 cm². The minimum height of each digit showing the measured quantities on LCD display shall be 8 mm.

The LCD display shall have the capability to operate under temperature up to 70 °C.

The register unit shall have the following display operating modes:

- (1) Scrolling mode, shall be programmable the data such as kWh, kvarh and other measuring data will be shown on the display in sequence automatically. The scrolling time shall be programmable up to 15 seconds.
- (2) Manual mode, the push button or switch on the meter's panel shall be used for starting the display sequence and showing the various stored data.

1c.5 Features and functions

1c.5.1 Tampering detection and alarms for 1-phase meters

The 1-phase meters shall have the following tampering detection features and shall be able to record, show alarm signal on the display according to manufacturer's design and register forward energy correctly and accurately under the following conditions:

- (1) Input phase and neutral connections are interchanged.
- (2) Incoming main is connected to outgoing terminals and load is connected to incoming terminals.
This function shall be programmable to disable by the supporting software.
- (3) A combination of conditions (1) and (2) occurs.
- (4) Load return is connected to a local earth and not returned to the 1-phase meters as well as the phase and neutral at supply side are reversed.
- (5) A combination of (1) and (4) or (3) and (4) occurs.
- (6) In case current bypass is detected, the 1-phase meters shall record the higher current between the measuring element (phase and neutral measuring element).
- (7) In case missing neutral is detected, the Actual Load, Operating Voltage and Unity Power Factor shall be recorded. The backup power supply shall support up to 60-day-continuous operation in this condition. In this case, the 1-phase meters shall display various stored data as shown in **1c.4 Measured values and register unit** when the push button or switch is pressed.
- (8) In case terminal cover is opened, the alarm signal shall appear event the terminal cover is removed and fitted again with the meter base. The indication shall disappear after command by supporting software. In case of the 1-phase meters without "Terminal cover open indication", the bidder shall provide other equivalent methods such as unopened and sealed box.
- (9) Magnetic immunity from any direction on the external surface of the 1-phase meters. (In case the bidder is not specify the detail of magnetic immunity test, the test method according to Clause No.-8.2 of IEC 62053-21 shall be applied.)
- (10) Other tampering events according to manufacturer's design.

A method for each condition of tampering detection shall be described by the bidders.

The example of the tampering features (1) to (7) as shown in **ANNEX 1: Table 1A**.



1c.5.2 Tampering detection and alarms for 3-phase meters

The 3-phase meters shall have the following tampering detection features and shall be able to record, show alarm signal on the display according to manufacturer's design and register forward energy correctly and accurately under the following conditions:

- (1) Incoming main is connected to outgoing terminals and load is connected to incoming terminals. This function shall be programmable to disable by the supporting software.
- (2) In case terminal cover is opened, the alarm signal shall appear event the terminal cover is removed and fitted again with the meter base. The indication shall disappear after command by supporting software. In case of the 3-phase meters without "Terminal cover open indication", the bidder shall provide other equivalent methods such as unopened and sealed box.
- (3) Magnetic immunity from any direction on the external surface of the 3-phase meters. (In case the bidder is not specify the detail of magnetic immunity test, the test method according to Clause No.-8.2 of IEC 62053-21 applied.)
- (4) Other tampering events according to manufacturer's design.

A method for each condition of tampering detection shall be described by the bidders.

1c.5.3 Over voltage protection

The meters shall have "Over voltage indication" in case the terminal voltage exceed 15% of operating voltage.

1c.6 Local communication

The meters shall have local communication interfaces as follows:

- (1) Optical port for data retrieval and for configuration of all parameters of the meters. The physical of the port shall be according to IEC 62056-21.
- (2) RS485 or RS232 interface for connecting to external communication devices.

1c.7 Functional self-checking

The meters shall be able to check its functional failures and display them on the meter's panel. The functional failures checked by the meters itself are as follows:

- (1) Internal failures such as clock fail, memory fail, etc.
- (2) Low battery (if the battery is used)
- (3) Other functional checking according to manufacturer's design

1c.8 Real time clock and calendar

The meters shall have an internal real time clock and/or a crystal-controlled time clock for providing calendar functions (i.e. the time of day, date, year, etc.). The accuracy of the clock shall be ± 2.0 seconds per day, or better.

1c.9 Power supply

The meters shall consume power from the main line power supply. For 3-phase meters, missing of any single phase or two phases of the power supply or missing of neutral line shall not affect performance of the meters.

1c.10 Backup power supply

Backup power supply shall be provided for keeping time in case of a power outage. Backup power supply shall be battery and/or super capacitor. The backup power supply or other equipment shall have minimum life span of 10 years with operating capacity minimum of 2 years. Socket type replaceable battery (if a battery is proposed) installed under meter's terminal cover is preferable. It shall be possible to change the backup power supply with the meters service. The backup power supply shall be supplied separately from the meters to avoid battery consumption during transportation and storage. The backup power supply shall be commercially available.

PEA will also accept the rechargeable battery according to above condition.

1c.11 Security system

The meters shall have a sophisticated security system to prevent fraudulent interference i.e. changing the tariff data or changing the meters reading via local communication.

The meters shall have at least three (3) groups of accessible password as follows:

- (1) Group 1 : Password for administrators to write the software and set the system of the meters
- (2) Group 2 : Password for programmers to program the operating functions of the meters
- (3) Group 3 : Password for readers to read the stored data, including to correct the time of the meters

1c.12 Supporting software

The supporting software shall have at least the following features and functions:

- Graphical User Interface (GUI) based
- Manual data retrieval
- Display all measured quantities
- Uploading firmware¹⁰⁾
- User authenticity on access levels
- Manual data export to OLEDB/ODBC databases for storage and management
- Exporting the billing data in form of ASCII text file with delimited space and the text file shall be able to process the data by Microsoft Excel. Each file shall be separately kept the billing data of each customer. The format of each line shall be specified in **Table 5: Format of billing data.**
- Supporting meter calibration¹⁰⁾
- Operating on Microsoft Windows 7, or later version

Note: ¹⁰⁾ PEA will also accept the proposed supporting software without uploading firmware and/or supporting meter calibration functions, but in this case it's responsibility of the contractor and the meter's manufacturer to upload firmware and/or calibrate the meters when the meters have a malfunction, for the whole lifetime of the meters (ten (10) years commencing from the date of the meters are accepted by PEA). The contractor and/or the meter's manufacturer shall take responsibility within thirty (30) calendar days counted from the date of receiving notice for PEA.



Table 5

Format of billing data

Field No.	Description	Type	Format
1	PEA CODE	Char (7)	xxxxxxx
2	COLLECTION	Char (3)	xxx
3	USER NO.	Char (6)	xxxxxx
4	PEA NO.	Char (10)	xxxxxxxxxx
5	Date	Char (8)	dd/mm/yy
6	Time	Char (5)	hh:mm
7	Number of reset	Numeric (2)	xx
8	Total kilowatt-hour, import (last reset)	Numeric (7)	xxxx.xx
9	Total kilovar-hour, import (last reset)	Numeric (7)	xxxx.xx
10	Total kilowatt-hour, export (last reset)	Numeric (7)	xxxx.xx
11	Total kilovar-hour, export (last reset)	Numeric (7)	xxxx.xx
12	Total kilowatt-hour, absolute (last reset)	Numeric (7)	xxxx.xx
13	Total kilovar-hour, absolute (last reset)	Numeric (7)	xxxx.xx

- Note:**
1. Data in field no. 1, 2, 3, and 4 are used to identify each customer identity and will be inputted by PEA.
 2. The billing data shall be the same data showing on the register unit.
 3. The meters shall be able to record at least 12 billing periods of the billing data.
 4. All billing data in Table 5 shall have the heading description and values for giving more detail of all data in order to understand easily. (Only value without heading description will be rejected.)

1c.13 Meter cabinet

The meter cabinets shall be provided for protection the direct connected electronic energy meters. The meter cabinets shall be made of aluminium or steel suitable for outdoor installation on concrete poles. All ferrous materials shall be galvanized. The meter cabinets shall be suitable for installation meter plate inside, details of the meter plate is according to Drawing No. SB4-015/58001.

The meter cabinets for direct connected meters shall be the bottom-connected type. The door shall be lockable type according to manufacturer design.

The detail and drawing with dimensions and tolerances of the proposed cabinets shall be submitted with the bid.

- Note:**
1. Requirements for each item of the meter cabinets are specified in “C3 Schedule of detailed requirement”
 2. A meter cabinet with a different design will be also accepted but the design and the drawing of the proposed cabinet shall be submitted to PEA for approval.

1c.14 Calculation of the Mean Time to Failure

The documents such as calculation sheets, test reports, etc. showing the Mean Time to Failure (MTTF) of the proposed meters is equal or more than 10 years shall be submitted with the bid.

1c.15 Samples

The bidders have to supply three (3) samples of the proposed meters to PEA within five (5) working days counted from the bid closing date. The bidders who cannot supply the samples shall be rejected.

PEA reserves the right to test/check the samples according to the test items specified in **Table 6: Sample test/check items**. In case of the failing test/check results, the bidders shall be rejected.

The samples will be returned after the test is finished.

Table 6

Sample test/check items

Major test/check items
<ol style="list-style-type: none"> 1. Type test items according to reference standards such as tests of accuracy requirements, tests of insulation properties 2. Physical properties checking, consisting of: <ol style="list-style-type: none"> 2.1 Mounting (see 1c.3.1) 2.2 Terminals and terminal block (see 1c.3.4) 2.3 Meter cover, terminal cover and security sealing (see 1C.3.3 and 1c.3.5) 2.4 Register unit (see 1c.4) 3. Function test, consisting of: <ol style="list-style-type: none"> 3.1 Power supply (see 1c.9)
Minor test/check items
<ol style="list-style-type: none"> 1. Function test, consisting of: <ol style="list-style-type: none"> 1.1 Tampering detection and alarms for 1-phase meters (see 1c.5.1) 1.2 Tampering detection and alarms for 3-phase meters (see 1c.5.2) 1.3 Functional self-checking (see 1c.7) 1.4 Security system (see 1c.11) 2. Communications (see 1c.6) 3. Supporting and Head End software (see 1c.12)
Other test/check items
<ol style="list-style-type: none"> 1. Marking (see 1c.3.6)

- Note:**
1. The major test/check items mean the samples shall be completely passed the test/check without any correction.
 2. For the minor test/check items, if the samples failed the tests/checks, PEA will allow the bidders to correct software or firmware, only one (1) time, within fifteen (15) days count from date of issuance of the notice from PEA's bidding committee, the corrected samples shall be passed all the minor test/check items. PEA will not allow the bidders to change the samples or take the samples back in the correction period.
 3. For the other test/check items, if the samples failed the tests/checks, PEA will give a notice for correction to the bidders. The bidder who wins the bid shall be correct the meters according the notice before delivery.



1d Packing

Each unit of the meter and accessory shall be packed in a suitable corrugate-paper package to avoid damage during transportation.

The meters of the same item shall be packed in a suitable wooden case in units of 100 or 120 for 1-phase meters and 10 or 50 for 3-phase meters.

The wooden case shall be designed to be movable by a forklift truck in such a manner that the truck's forks can be inserted at any side of the bottom of the case.

If the wooden case is made of rubber wood (Yang-para or Hevea brasiliensis), the wooden parts shall be treated with wood preservative.

Plastic foam shall not be accepted.

1e Tests and test reports

1e.1 Routine test

Each meter shall pass the manufacturer's standard routine tests, and also pass the following tests in accordance with the relevant standards:

- 1) AC voltage tests
- 2) Limits of error due to variation of the current
- 3) Interpretation of test results (In case test results fall outside the limits in 2)
- 4) Test of meter constant
- 5) Initial start-up of the meter
- 6) Test of starting condition
- 7) Test of no-load condition
- 8) Test of tampering detection

The list of routine test shall be submitted with the bid.

1e.2 Type test

Meter shall pass the following type tests in accordance with the TIS 1030 and TIS 2543 standards (or IEC 62052-11 and IEC 62053-21 standards):

- 1) Tests of insulation properties
 - 1.1) Impulse voltage tests
 - 1.2) AC voltage tests



ELECTRONIC ENERGY METERS

Specification No.: RMTR-035/2561

Approved date: 31/05/2561

Rev. No.: 1

Form No. 03-11.9

Page 14 of 19

- 2) Tests of accuracy requirements
 - 2.1) Limits of error due to variation of the current
 - 2.2) Interpretation of test results (In case test results fall outside the limits in 2.1)
 - 2.3) Test of meter constant
 - 2.4) Initial start-up of the meter
 - 2.5) Test of starting condition
 - 2.6) Test of no-load condition
 - 2.7) Test of influence quantities
- 3) Tests of electrical requirements
 - 3.1) Test of power consumption
 - 3.2) Test of influence of supply voltage
 - 3.3) Test of influence of short-time overcurrents
 - 3.4) Test of influence of self-heating
 - 3.5) Test of influence of heating
- 4) Tests for electromagnetic compatibility (EMC)
 - 4.1) Radio interference suppression
 - 4.2) Fast transient burst test
 - 4.3) Damped oscillatory waves immunity test (only for CT operated meters)
 - 4.4) Test of immunity to electromagnetic RF fields
 - 4.5) Test of immunity to conducted disturbances, induced by radio-frequency fields
 - 4.6) Test of immunity to electrostatic discharges
 - 4.7) Surge immunity test
- 5) Tests of the effect of the climatic environments
 - 5.1) Dry heat test
 - 5.2) Cold test
 - 5.3) Damp heat, cyclic test
 - 5.4) Solar radiation test
- 6) Mechanical tests
 - 6.1) Vibration test
 - 6.2) Shock test
 - 6.3) Spring hammer test
 - 6.4) Tests of protection against penetration of dust and water
 - 6.5) Test of resistance to heat and fire

The type tests shall be conducted or inspected by the acknowledged testing laboratories/institutes as following:

- (1) Independent laboratories/institutes which are members of the Short-circuit Testing Liaison (STL) or independent laboratories/institutes which are accredited according to TIS 17025 or ISO/IEC 17025 with the scope of accreditation covered the relevant test items, standards and equipment. The certification and scope of accreditation of the independent laboratories/institutes shall be submitted with the bid for consideration.
- (2) Thailand's national laboratories, institutes, universities and electric utilities, as follows:
 - National Metal and Materials Technology Center (MTEC)
 - Electrical and Electronic Products Testing Center (PTEC)
 - Thai Industrial Standards Institute (TISI)
 - Electrical and Electronics Institute (EEI)
 - Department of Science Service (DSS)
 - Testing Laboratory, Electrical Engineering Department, Faculty of Engineering, Chulalongkorn University
 - Electricity Generating Authority of Thailand (EGAT)
 - Metropolitan Electricity Authority (MEA)
 - Provincial Electricity Authority (PEA)
 - Other laboratories, institutes, universities or electric utilities approved by PEA

In case of the foreign manufacturers having experience of more than twenty (20) years in design, manufacture and sell the meters, PEA will accept type test report(s) conducted by the manufacturer's laboratory or other independent laboratories without qualification mentioned in (1) or (2). Documents showing the manufacturer's experience such as reference list shall be submitted with the bid for consideration.

The bidders or manufacturers who prefer to carry out the type tests of the meters with the laboratories or by the manufacturers themselves without the qualification mentioned above, the detail of the test facilities of the laboratories or the manufacturer shall be submitted to PEA for approval before proceeding the tests and before the bid closing date. PEA reserves the right to send representatives to inspect and witness the tests with the cost of the bidders or manufacturers.

The type test report done by the laboratories in Thailand or local manufacturers shall be valid within five (5) years counted from the issued date in the test report to the bid closing date.

The type test reports shall be submitted with the bid.

PEA will also accept other documents instead of the type test reports and type test certificates in the following conditions:

- (1) In case the proposed meters has been supplied to PEA and get the order from PEA's Procurement Department (from PEA's head office), the Purchase Order (PO) can be submitted, or
- (2) In case the proposed meters has been registered for PEA Product Acceptance, the not-expired registration certificate counted to the bid closing date can be submitted, or
- (3) In case the proposed meters has been registered for Product lists for substation turnkey project, the not-expired registration certificate counted to the bid closing date can be submitted instead

However the document in case (1) and (2) shall be proved that the meters specified in the PO or registration certificate shall be the same product, type/model and all ratings as the proposed meters for this bid and shall be used the same PEA's specification number. In case (3), the meters specified in the registration certificate shall be the same product, type/model and all ratings as the proposed meters for this bid.

The cost of all tests and reports shall be borne by the bidders.

1e.3 Acceptance tests

PEA's acceptance committee will inspect and randomly sampling the meters for testing. The number of the samples shall be not less than thirty-two (32) samples per lot. All samples shall be passed the tests otherwise the contract will be rejected.

PEA reserves the right to test the samples by PEA's laboratory or independent laboratory or the manufacturer's laboratory.

The acceptance test items shall be as follows:

- 1) AC voltage tests
- 2) Limits of error due to variation of the current
- 3) Interpretation of test results (In case test results fall outside the limits in 2)
- 4) Test of meter constant
- 5) Initial start-up of the meter
- 6) Test of starting condition
- 7) Test of no-load condition
- 8) Test of tampering detection

The cost of the acceptance tests and reports shall be borne by the contractor.



1f Other critical documents

The other critical documents of the proposed electronic energy meters and accessories shall be submitted with the bid as follows:

- 1) Catalogue, rating and characteristics of the electronic energy meters, communication modules and accessories
- 2) Description of materials, surface treatment, and surface finishing of the component parts
- 3) Details and drawings, with dimensions in mm, of the electronic energy meters, communication modules and accessories
- 4) Description of the supplied communication and supporting software
- 5) Sufficient references describing the previous experience of the suppliers (e.g. list of supply of equipment and/or materials having the same or similar design as proposed, field experience, the registration of TISI, the copies of license, and/or the inspection to supplier's factory by PEA's inspectors, etc.)



C2 Material and packing data of the electronic energy meters

The following guarantee performances and details shall be submitted with the bid:

2a Critical documents of the proposed electronic energy meters and accessories (See pages 19 of 19).

2b Packing details

Packing method (shown by drawing(s), and describe packing materials, wooden case only)

Dimensions of each package in cm

Gross weight of each package in kg

Net weight of each package in kg

Number of packages in each wooden case

Volume of each wooden case in m³

Gross weight of each wooden case in kg

Number of wooden cases

Type of storage facility required (indoor, outdoor)

Note: Conditions for documentation and consideration

1. The Contractor has to supply the following documents in English and/or Thai, before shipment/delivery, for each type of the ordered meters and accessories.

1.1 Reports of type tests and routine tests

1.2 Twelve (12) copies of complete installation, operation, and maintenance instructions.

1.3 Twelve (12) copies of complete part lists

1.4 Six (6) copies of instruction of the communication protocol and security system

1.5 Six (6) copies of software handbooks for users and programmers

The above documents shall be sent to the following address:

Meter and Transformer System Department

Provincial Electricity Authority

200 Ngam Wong Wan Road, Chatuchak

Bangkok Metropolis Thailand

10900

2. Delivery time is also one of the important factors to be considered.

3. Partial shipment/delivery is allowed.



Critical documents of the proposed electronic energy meters and accessories

Required technical document	Proposed technical document	Reference document (page/folder)
Catalogue, rating and characteristics of the electronic energy meters, communication modules and accessories	<input type="checkbox"/> Yes <input type="checkbox"/> No	
Type test certificates and/or test reports with detail of the laboratories/institutes	<input type="checkbox"/> Yes <input type="checkbox"/> No	
Description of materials, surface treatment, and surface finishing of the component parts	<input type="checkbox"/> Yes <input type="checkbox"/> No	
Details and drawings, with dimensions in mm, of the electronic energy meters, communication modules and accessories	<input type="checkbox"/> Yes <input type="checkbox"/> No	
Description of the supplied communication and supporting software	<input type="checkbox"/> Yes <input type="checkbox"/> No	
Details and drawings, with dimensions in mm, of the meter cabinets	<input type="checkbox"/> Yes <input type="checkbox"/> No	
List of routine tests	<input type="checkbox"/> Yes <input type="checkbox"/> No	
Documents such as calculation sheets, test reports, etc. showing the Mean Time to Failure (MTTF) of the proposed electronic energy meters is equal or more than 10 years.	<input type="checkbox"/> Yes <input type="checkbox"/> No	
Sufficient references describing the previous experience of the suppliers (e.g. list of supply of equipment and/or materials having the same or similar design as proposed, field experience, the registration of TISI, the copies of license, and/or the inspection to supplier's factory by PEA's inspectors, etc.)	<input type="checkbox"/> Yes <input type="checkbox"/> No	
Documents for showing the manufacturer's experience. (In case of test by the manufacturer's laboratory or other independent laboratories without qualification mentioned in (1) or (2) of 1e.2 Type test)	<input type="checkbox"/> Yes <input type="checkbox"/> No	

Note: The bidders who do not submit all critical documents mentioned in the above table with the bid will be rejected.

C3 Schedule of detailed requirement

Invitation to Bid No.:

Item	PEA Material No.	Quantity	Description
1	1060050018	set(s)	Electronic energy meter, 1-phase 2-wire, direct connected, with: Operating voltage : 230 ± 10 % V AC Current rating, $I_b(I_{max})$: 5(100) A Complete with: 1) Supporting software 2) Instruction manual in Thai and English 3) And other according to manufacturer's design (give details)
2	1060100024	set(s)	Meter cabinet, according to Drawing No. SB4-015/61001, for two (2) electronic energy meters, 1-phase 2-wire, direct connected, with ground terminal connector for copper conductor diameter range of 2.25 to 5.1 mm (sizes 4 – 16 mm ²)
3	1060100025	set(s)	Meter cabinet, according to Drawing No. SB4-015/61001, for four (4) electronic energy meters, 1-phase 2-wire, direct connected, with ground terminal connector for copper conductor diameter range of 2.25 to 5.1 mm (sizes 4 – 16 mm ²)
4	1060050109	set(s)	Electronic energy meter, 3-phase 4-wire, direct connected, with: Operating voltage : 230/400 ± 10 % V AC Current rating, $I_b(I_{max})$: 5(100) A Complete with: 1) Supporting software 2) Instruction manual in Thai and English 3) And other according to manufacturer's design (give details)
5	1060100020	set(s)	Aluminium cabinet, according to Drawing No. SA2-015/52013, for electronic energy meters, 3-phase 4-wire, direct connected, with ground terminal connector for copper conductor diameter range of 2.25 to 5.1 mm (sizes 4 – 16 mm ²)

C3 Schedule of detailed requirement

Invitation to Bid No.:

Item	PEA Material No.	Quantity	Description
6	1060050110	set(s)	<p>Electronic energy meter, 3-phase 4-wire, CT operated, with:</p> <p>Operating voltage : 230/400 ± 10 % V AC</p> <p>Current rating, $I_n(I_{max})$: 5(6) A</p> <p>Complete with:</p> <ol style="list-style-type: none"> 1) Supporting software 2) Instruction manual in Thai and English 3) And other according to manufacturer's design (give details)
7	1060100008	set(s)	<p>Steel cabinet, according to Drawing No. SA1-015/22041, for electronic energy meters, 3-phase 4-wire, CT operated, with low tension current transformer, with ground terminal connector for copper conductor diameter range of 2.25 to 5.1 mm (sizes 4 – 16 mm²)</p> <p>Note:</p> <ol style="list-style-type: none"> 1. The bidders have to quote the unit costs. 2. The bidders have to submit the sufficient references describing the previous experience of the suppliers (e.g. list of supply of equipment and/or materials having the same or similar design as proposed, field experience, the registration of TISI, the copies of license, and/or the inspection to supplier's factory by PEA's inspectors, etc.) to the satisfaction of PEA . 3. Training course conducted by specialist from manufacturer shall be provided by the contractor, for PEA's personnel, not less than two (2) days, for installation, operation, configuration and maintenance of the meters including the software. The training course shall be free of charge. 4. The contractor has to guarantee the quality of the meters for three (3) years commencing from the date PEA receive the above mentioned meters and accessories at the final lot. <p>During the guarantee period, the contractor shall replace the defective meters for free of charge or pay an amount equal to the exact purchasing value for the defective quantity of the meters and/or accessories within thirty (30) calendar days counted from the date of receiving notice from PEA.</p>



การไฟฟ้านครหลวง
PROVINCIAL ELECTRICITY AUTHORITY

PROVINCIAL ELECTRICITY AUTHORITY

TECHNICAL SPECIFICATION DIVISION

Specification No.: RMTR-035/2561: ELECTRONIC ENERGY METERS

Page 1 of 3

C4 Price schedule

Invitation to Bid No.:

Manufacturer :

Country of origin :

Trade-mark :

Item	PEA Material No.	Catalogue No.	Description	Quantity	Unit Cost (See details & conditions attached)	Total Cost (See details & conditions attached)
1	1060050018		<p>Electronic energy meter, 1-phase 2-wire, direct connected, with:</p> <p>Operating voltage : 230 ± 10 % V AC</p> <p>Current rating, $I_b(I_{max})$: 5(100) A</p> <p>Complete with:</p> <ol style="list-style-type: none"> 1) Supporting software 2) Instruction manual in Thai and English 3) And other according to manufacturer's design (give details) 	set(s)		
2	1060100024		Meter cabinet, according to Drawing No. SB4-015/61001, for two (2) electronic energy meters, 1-phase 2-wire, direct connected, with ground terminal connector for copper conductor diameter range of 2.25 to 5.1 mm (sizes 4 – 16 mm ²)	set(s)		
3	1060100025		Meter cabinet, according to Drawing No. SB4-015/61001, for four (4) electronic energy meters, 1-phase 2-wire, direct connected, with ground terminal connector for copper conductor diameter range of 2.25 to 5.1 mm (sizes 4 – 16 mm ²)	set(s)		
	II					



การไฟฟ้านครหลวง
PROVINCIAL ELECTRICITY AUTHORITY

PROVINCIAL ELECTRICITY AUTHORITY

TECHNICAL SPECIFICATION DIVISION

Specification No.: RMTR-035/2561: ELECTRONIC ENERGY METERS

Page 2 of 3

C4 Price schedule

Invitation to Bid No.:

Manufacturer :

Country of origin :

Trade-mark :

Item	PEA Material No.	Catalogue No.	Description	Quantity	Unit Cost (See details & conditions attached)	Total Cost (See details & conditions attached)
4	1060050109		<p>Electronic energy meter, 3-phase 4-wire, direct connected, with:</p> <p>Operating voltage : 230/400 ± 10 % V AC</p> <p>Current rating, $I_b(I_{max})$: 5(100) A</p> <p>Complete with:</p> <ol style="list-style-type: none"> 1) Supporting software 2) Instruction manual in Thai and English 3) And other according to manufacturer's design (give details) 	set(s)		
5	1060100020		<p>Alumimium cabinet, according to Drawing No. SA2-015/52013, for electronic energy meters, 3-phase 4-wire, direct connected, with ground terminal connector for copper conductor diameter range of 2.25 to 5.1 mm (sizes 4 – 16 mm²)</p>	set(s)		
	II					



การไฟฟ้านครหลวง
PROVINCIAL ELECTRICITY AUTHORITY

PROVINCIAL ELECTRICITY AUTHORITY

TECHNICAL SPECIFICATION DIVISION

Specification No.: RMTR-035/2561: ELECTRONIC ENERGY METERS

Page 3 of 3

C4 Price schedule

Invitation to Bid No.:

Manufacturer :

Country of origin :

Trade-mark :

Item	PEA Material No.	Catalogue No.	Description	Quantity	Unit Cost (See details & conditions attached)	Total Cost (See details & conditions attached)
6	1060050110		<p>Electronic energy meter, 3-phase 4-wire, CT operated, with:</p> <p>Operating voltage : 230/400 ± 10 % V AC</p> <p>Current rating, $I_n(I_{max})$: 5(6) A</p> <p>Complete with:</p> <ol style="list-style-type: none"> 1) Supporting software 2) Instruction manual in Thai and English 3) And other according to manufacturer's design (give details) 	set(s)		
7	1060100008		<p>Steel cabinet, according to Drawing No. SA1-015/22041, for electronic energy meters, 3-phase 4-wire, CT operated, with low tension current transformer, with ground terminal connector for copper conductor diameter range of 2.25 to 5.1 mm (sizes 4 – 16 mm²)</p>	set(s)		
	II					



ANNEX 1

EXAMPLE OF TAMPERING FEATURES

The electronic energy meter shall have the following tampering detection features and shall be able to record, show alarm signal on the display according to manufacturer's design and register forward energy correctly and accurately under the following conditions as shown in **Table 1A**.

Table 1A

Example of tampering

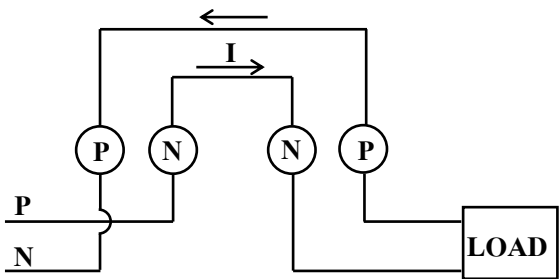
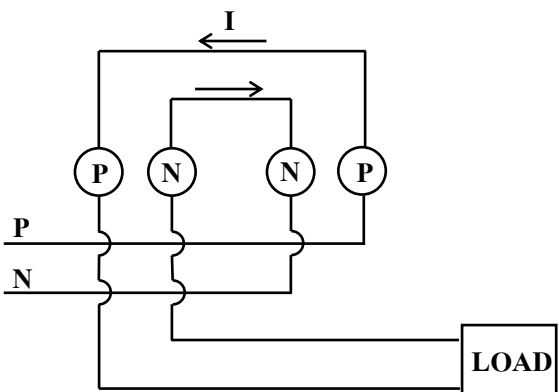
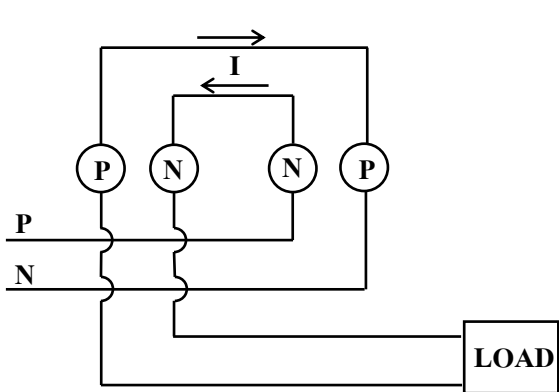
Example of tampering	Descriptions
 <p style="text-align: center;">Figure 1</p>	<p>Input phase and neutral connections are interchanged.</p>
 <p style="text-align: center;">Figure 2</p>	<p>Incoming main is connected to outgoing terminals and load is connected to incoming terminals.</p>
 <p style="text-align: center;">Figure 3</p>	<p>Input phase and neutral connections are interchanged and incoming main is connected to outgoing terminals and load is connected to incoming terminals.</p>

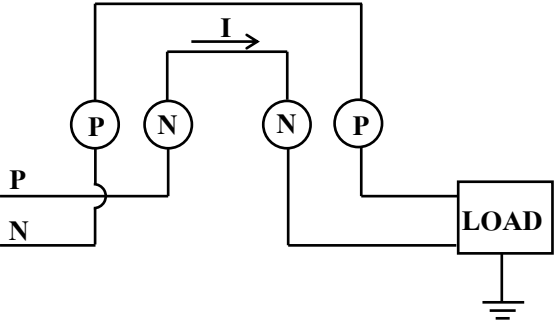
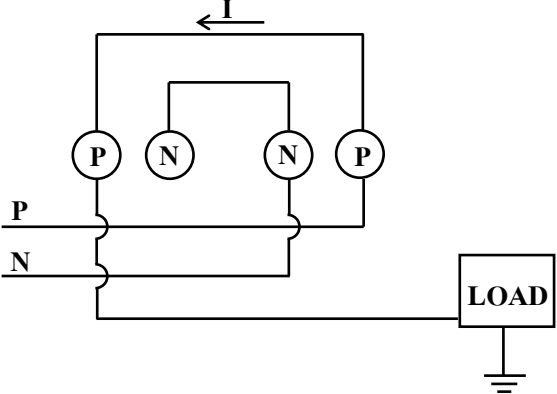
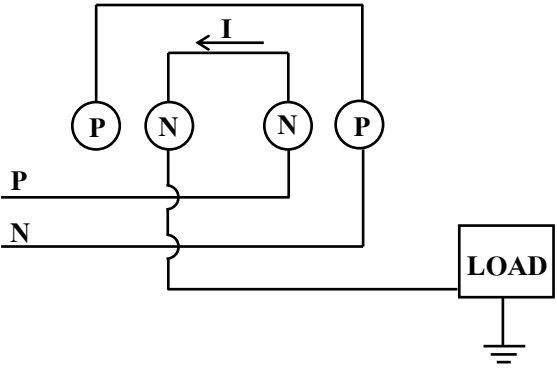

Example of tampering	Descriptions
 <p style="text-align: center;">Figure 4</p>	<p>Load return is connected to a local earth and not returned to the meters.</p>
 <p style="text-align: center;">Figure 5</p>	<p>Incoming main is connected to outgoing terminals and load is connected to incoming terminals and load return is connected to a local earth and not returned to the meters.</p>
 <p style="text-align: center;">Figure 6</p>	<p>Input phase and neutral connections are interchanged and incoming main is connected to outgoing terminals and load is connected to incoming terminals and load return is connected to a local earth and not returned to the meters.</p>

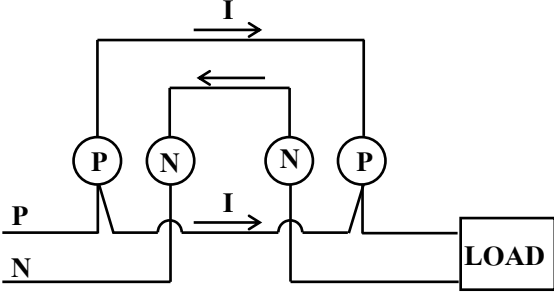
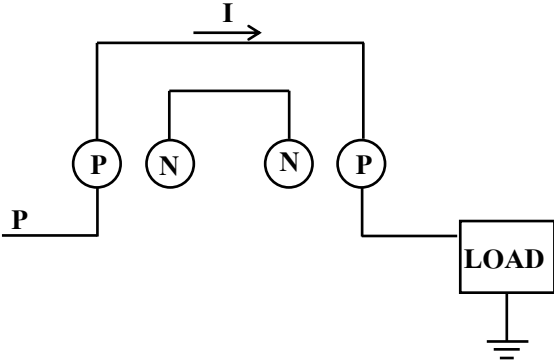

Example of tampering	Descriptions
 <p data-bbox="453 797 555 828">Figure 7</p>	<p data-bbox="833 421 1005 452">Current bypass</p>
 <p data-bbox="453 1258 555 1290">Figure 8</p>	<p data-bbox="833 846 1011 878">Missing neutral</p>

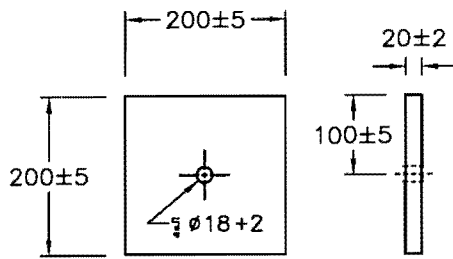

ขนาดแป้นรองมิเตอร์ 20x20 เซนติเมตร
 สำหรับยึดสายเข้า และออกจากมิเตอร์
 สำหรับติดตั้งมิเตอร์ 1 เฟส ที่เมนชายคา

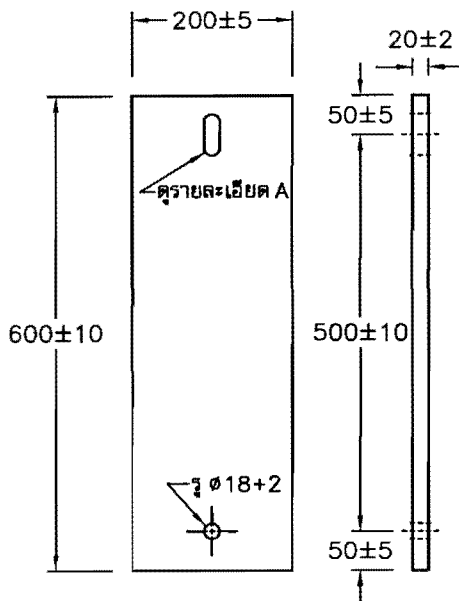

ขนาดแป้นรองมิเตอร์ 20x60 เซนติเมตร
 สำหรับมิเตอร์ 1-2 เครื่อง
 สำหรับรองรับมิเตอร์ที่ติดตั้งในตู้มิเตอร์

PRELIMINARY

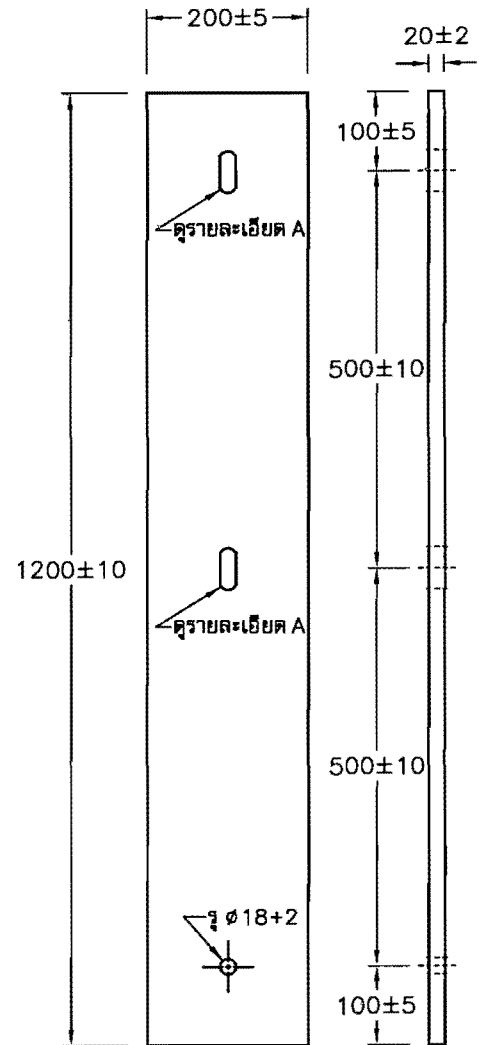

ขนาดแป้นรองมิเตอร์ 20x120 เซนติเมตร
 สำหรับมิเตอร์ 3-4 เครื่อง

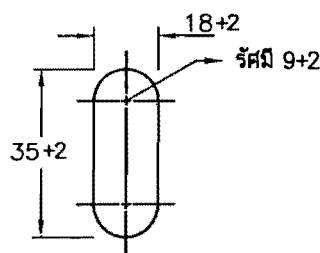

รูยึดสายเข้า A
 การเจาะรู 18x35 มิลลิเมตร

หมายเหตุ
 มิติเป็นมิลลิเมตร

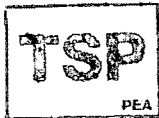

กองข้อกำหนดทางเทคนิค ฝ่ายวิศวกรรม	การไฟฟ้าส่วนภูมิภาค	ใช้แทนแบบ.....
ผู้เขียน... สิทธิพงษ์ มีใส	มาตรฐานของแป้นรองมิเตอร์	ถูกแทนโดยแบบ.....
ผู้สำรวจ.....		เขียนเสร็จวันที่ 30.11.2555
วิศวกร... วิทวัส ต้นภู	STANDARD OF METER PLATE	แก้แบบวันที่.....
หัวหน้าแผนก... มณฑล		มิติเป็น.....
ผู้อำนวยการกอง... <i>[Signature]</i>		มาตราส่วน.....
ผู้อำนวยการฝ่าย... <i>[Signature]</i>		แบบเลขที่ SB4-015/58001
		แผ่นที่ 1. ของจำนวน 1. แผ่น

PRELIMINARY

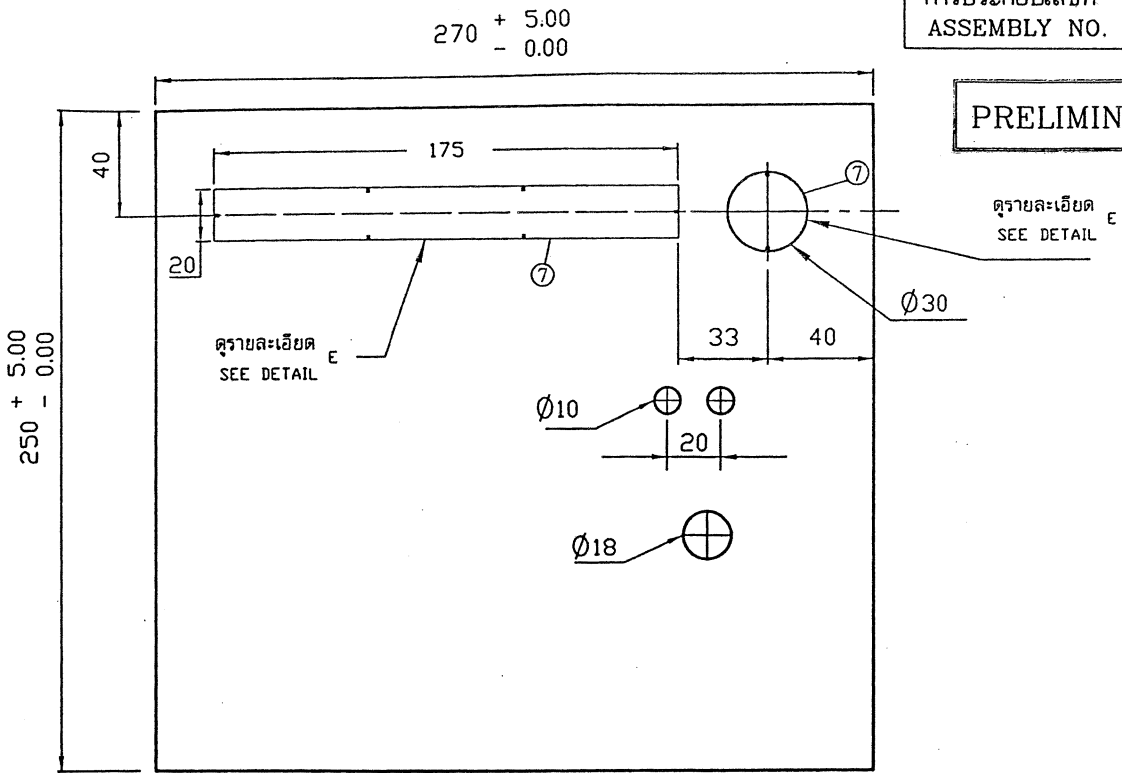

ภาพตัด A-A
SECTION

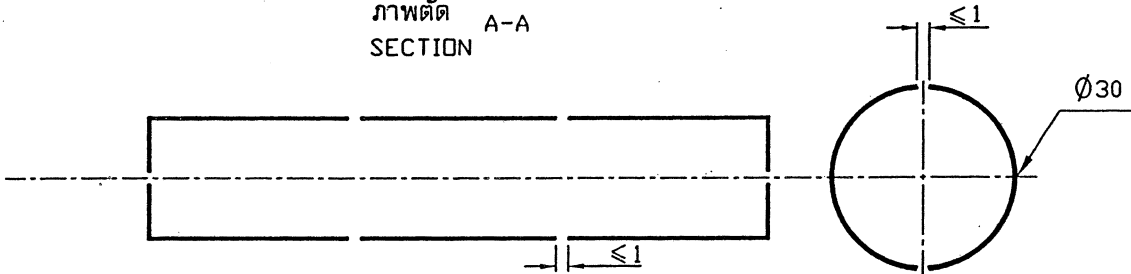

รายละเอียด E
DETAIL

1. ตู้ทำด้วยแผ่นอะลูมิเนียมความหนา 1.5 มม.
2. ขั้วยึดสายดินจับสายทองแดง ขนาด 4-16 มม. ประกอบด้วยสกรูทองเหลืองพร้อมนัท 2 ตัว (ดูรายละเอียด B)
3. แผ่นเหล็กอาบสังกะสี ความหนา 1.2 มม. และหมุดย้ำแบบไม่เป็นสนิม
4. บานพับทองเหลือง และหมุดย้ำแบบไม่เป็นสนิม
5. แผ่นเบ็คเกอร์ไลท์ (BAKELITE) หนา 8 มม. (5/16") เจาะรูสำหรับเข้าสายไฟฟ้าพร้อมสกรูยึดกับแผ่นอะลูมิเนียม 6 ตัว
6. หน้าต่างโพลีคาร์บอเนตใส (POLYCARBONATE)
7. ช่องเข้าสายไฟฟ้าทำเป็นแบบน็อกเอาท์ (KNOCKOUT)

หมายเหตุ

ค่าความคลาดเคลื่อนของรูเข้าสายไฟฟ้าเป็น ± 0.1 มม.

<p>กองมาตรฐานระบบไฟฟ้า ฝ่ายมาตรฐานและความปลอดภัย</p>	<p>การไฟฟ้าส่วนภูมิภาค</p>	<p>ใช้แทนแบบ SA1-015/22042 SA1-015/22048 ถูกแทนโดยแบบ</p>
<p>ผู้เขียน ลิทธิพงษ์ มีใส ผู้สำรวจ</p>	<p>ผู้ว่าการ</p>	<p>เขียนเสร็จวันที่ 15 ต.ค. 2552 แก้แบบวันที่</p>
<p>วิศวกร</p>	<p>ตู้อะลูมิเนียมใส่นอกอาคาร สำหรับมิเตอร์ 3 เฟส และมิเตอร์ทีโอยู</p>	<p>มิติเป็น มิลลิเมตร มาตราส่วน</p>
<p>รองผู้ว่าการวางแผน และพัฒนาระบบไฟฟ้า</p>	<p>OUTDOOR ALUMINIUM CABINET FOR THREE-PHASE METER AND TOU METER</p>	<p>แบบเลขที่ SA2-015/52013 แผ่นที่ 2 ของจำนวน 2 แผ่น</p>

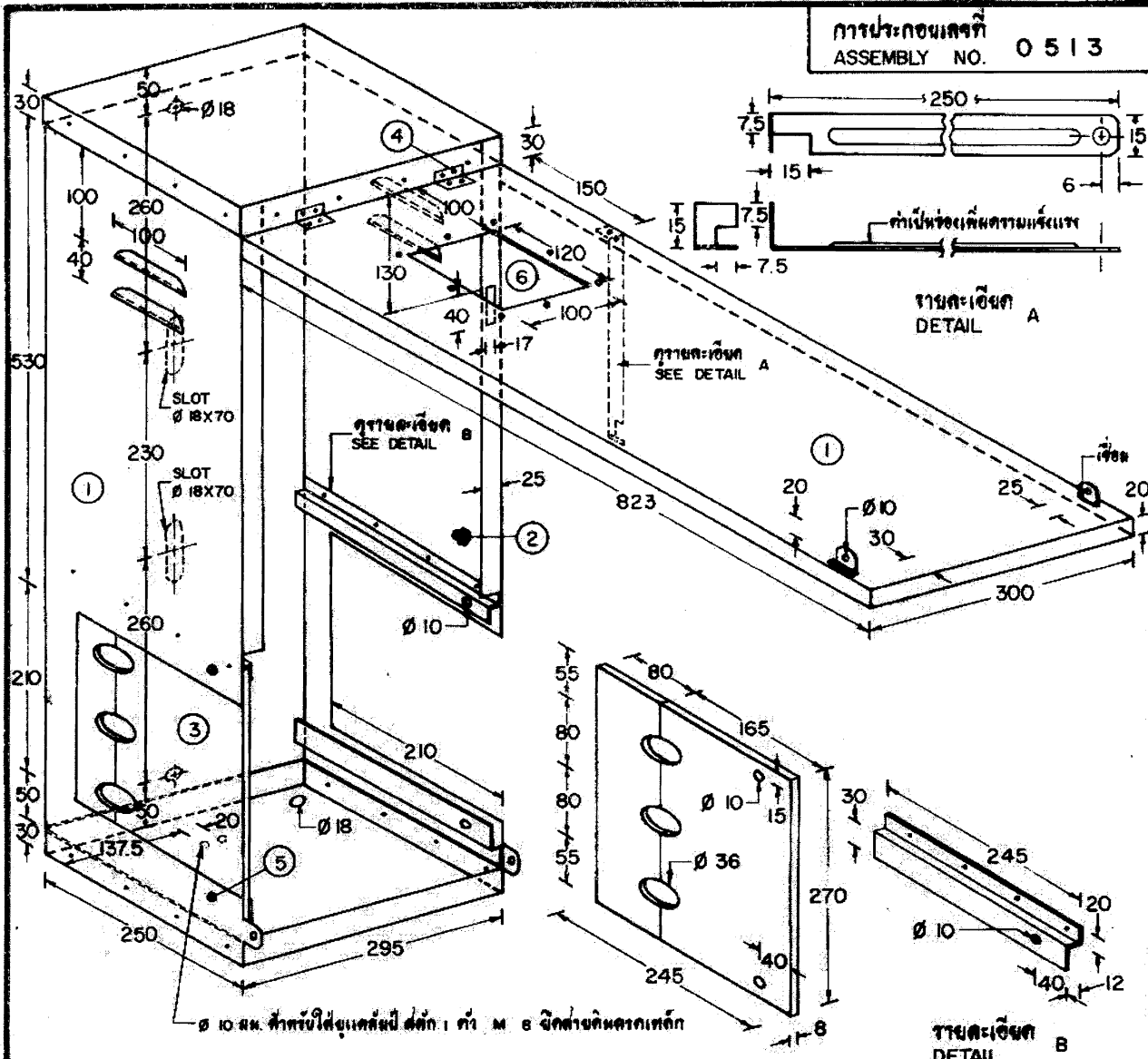

1. ตั้วทำด้วยแผ่นเหล็กขนาดที่กะลือ ความหนา: ๒.๒ มม. (BWG. 18) มอก. 50-2516
2. ขั้วขีดสายดินหุ้มสายทองแดง 4-16 ก.มม. ประกอบด้วยสกรูทองเหลือง พร้อมหัว 2 ตัว
3. แผ่นแบคเคอไรไลท์ (BAKELITE) หรือไฟเบอร์กลาสความหนา ๘ มม. (5/16) กัดและเจาะตามรูป
4. ขานพับทองเหลือง และหมุดขี้ผึ้งเป็นต้นนิยม
5. สลักเกลียว M 6 X 25 มม. พร้อมแหวนกลอน 2 ตัว และหัวที่ติดขม
6. หน้าทึบพลาสติกใสทนความร้อน (ARCYLIC) หรือเทียบเท่า

หมายเหตุ: ส่วนที่ติดตั้งและเจาะรูบนแผ่นเหล็ก ให้ทำตามที่ระบุไว้ที่หน้าพิมพ์ สีเทาอ่อน



กองวิศวกรรมไฟฟ้าและเครื่องกล ฝ่ายวิศวกรรม	การไฟฟ้าส่วนภูมิภาค	ในแผนก
ผู้เรียบ <i>[Signature]</i> ผู้สำรวจ <i>[Signature]</i> หัวหน้าแผนก <i>[Signature]</i> หัวหน้ากอง <i>[Signature]</i> ผู้อำนวยการ <i>[Signature]</i>	ผู้ว่าการ <i>[Signature]</i> ๒๖ ส.ค. ๒๕๒๒ ผู้อำนวยการบริษัทประกันชีวิต พร้อมชีวิต. มหาพำ	ถูกควบคุมโดยแผนก เขียนเสร็จวันที่ 30 ก.ค. 22 นักเขียนวันที่ นิติเป็น พ.ศ. มาตรฐาน I : 7.5
ขอแจ้งว่ากรรมสิทธิ์ใน <i>[Signature]</i>	STEEL CABINET FOR METER WITH LOW TENSION CURRENT TRANSFORMER	แผนกเลขที่ SAI-015/22041 แผ่นที่ 1 ของจำนวน 1 แผ่น

18 ส.ค. ๒๕๒๒

PRELIMINARY

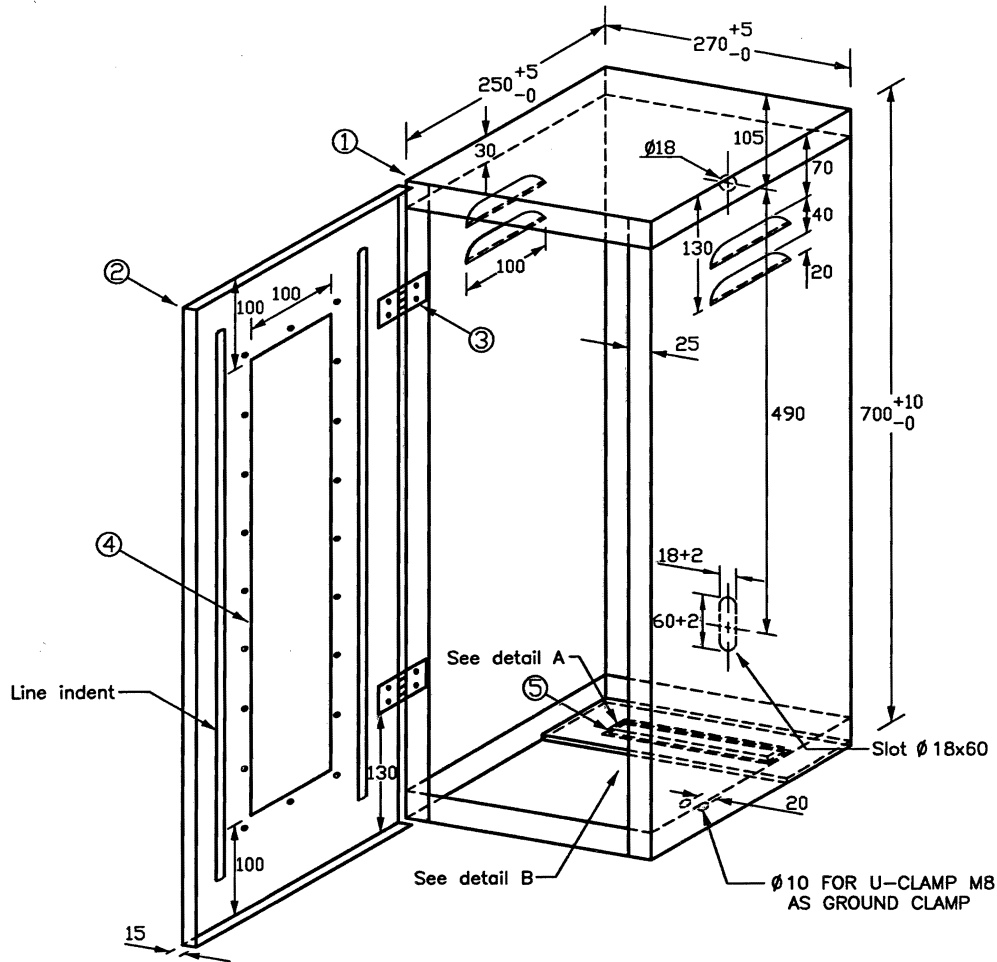

Meter cabinet, for two (2) single-phase electronic energy meters, outdoor installation

Note:

1. Unless otherwise specified, all tolerances shall be $\pm 10\%$.
2. All dimensions are in mm.
3. Not to scale.
4. A meter cabinet with a different design will be also accepted but the design and the drawing of the proposed cabinet shall be submitted to PEA for approval.



กองข้อกำหนดทางเทคนิค ฝ่ายวิศวกรรม	การไฟฟ้าส่วนภูมิภาค	ใช้แทนแบบ..... ถูกแทนโดยแบบ.....
ผู้เขียน...วิฑริส.ต้นฤ..... ผู้สำรวจ..... วิศวกร...วิฑริส..... หัวหน้าแผนก...วิฑริส.....	ตู้มิเตอร์สำหรับมิเตอร์อิเล็กทรอนิกส์ 1 เฟส ใช้ติดตั้งนอกอาคาร	เขียนเสร็จวันที่.15พ.ค.2561 แก้แบบวันที่..... มิติเป็น...มิลลิเมตร.....
ผู้อำนวยการกอง..... ผู้อำนวยการฝ่าย.....	Meter cabinet, for single-phase electronic energy meters, outdoor installation	มาตรฐาน..... แบบเลขที่ SB4-015/61001 แผ่นที่.1. ของจำนวน.3.แผ่น

PRELIMINARY

No.	Component	Description
1	Cabinet	- The thickness of aluminium cabinet shall not be less than 1.5 mm. - The thickness of steel cabinet shall not be less than 1.2 mm.
2	Door	The door shall be lockable type, according to manufacturer design.
3	Hinges	Hinges shall be made of brass.
4	Window	The window shall be made of transparent polycarbonate.
5	Bakelite plate	The thickness of bakelite plate shall not be less than 8 mm. (5/16"), hole for six (6) screws fitting.

Detail A : Detail of bakelite plate

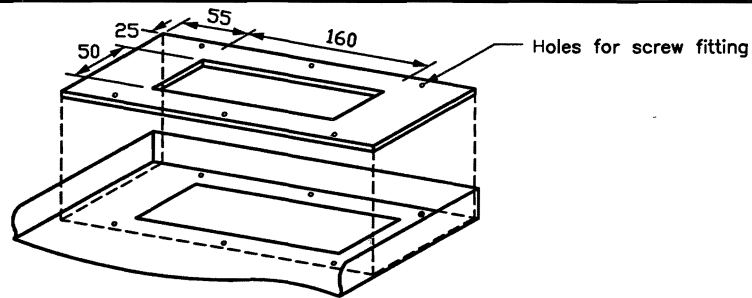

Detail B : Detail of Electrical knockout

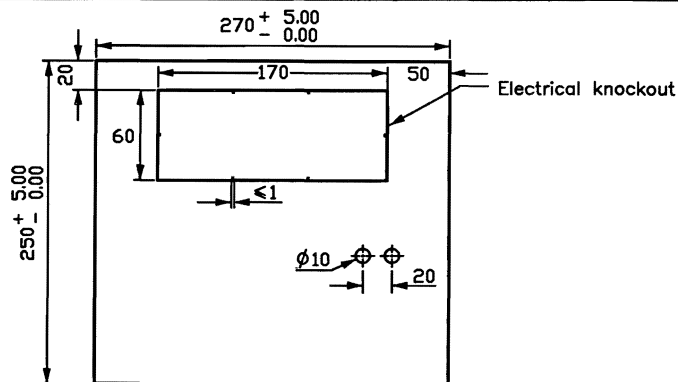

Note:

1. Unless otherwise specified, all tolerances shall be $\pm 10\%$.
2. All dimensions are in mm.
3. Not to scale.



กองข้อกำหนดทางเทคนิค ฝ่ายวิศวกรรม	การไฟฟ้าส่วนภูมิภาค	ใช้แทนแบบ..... ถูกแทนโดยแบบ.....
ผู้เขียน...วิฑวิศ.ต้นฤ..... ผู้สำรวจ..... วิศวกร...วิฑวิศ..... หัวหน้าแผนก...วิฑวิศ..... ผู้อำนวยการกอง...วิ..... ผู้อำนวยการฝ่าย.....	ตู้มิเตอร์สำหรับมิเตอร์อิเล็กทรอนิกส์ 1 เฟส ใช้ติดตั้งนอกอาคาร	เขียนเสร็จวันที่.15พ.ค.2561 แก้แบบวันที่..... มิติเป็น...มิลลิเมตร..... มาตราส่วน.....
	Meter cabinet, for single-phase electronic energy meters, outdoor installation	แบบเลขที่ SB4-015/61001 แผ่นที่.3. ของจำนวน.3.แผ่น