



PROVINCIAL ELECTRICITY AUTHORITY

TECHNICAL SPECIFICATION DIVISION

SINGLE-PHASE TRANSFORMERS FOR 22 kV and 33 kV 50 Hz DISTRIBUTION SYSTEMS

WITH ABILITY TO WITHSTAND SHORT CIRCUIT

Specification No. RTRN-047/2561

Approved date : 26/09/2561

Rev. No.: 1

Form No. -

Page 11 of 28

1c.14 Initial oil filling

The transformers shall be supplied with initial oil filling. The oil shall be according to IEC 60296, high-quality, clean and dry.

The oil shall be free from Polychlorinated Biphenyls (PCBs).

1c.15 Nameplate

The following minimum nameplate information shall be legibly and durably inscribed on the metal part of nameplate.

- (1) Manufacturer's name
- (2) Manufacturer's serial number
- (3) Year of manufacture
- (4) PEA's code number
- (5) Contract number and/or PO number
- (6) Number of phases
- (7) Rated frequency in Hz
- (8) Rated output in kVA
- (9) Rated voltage in V
- (10) Rated current in A
- (11) Tap voltages in V
- (12) Polarity
- (13) Per cent short-circuit impedance
- (14) Connection diagram
- (15) Type of cooling
- (16) Oil quantity in liter
- (17) Total weight in kg
- (18) Winding material (Made of copper)
- (19) Rated secondary short-circuit withstand current in kA r.m.s.
- (20) Wording "**SHORT CIRCUIT WITHSTAND**"

SINGLE-PHASE TRANSFORMERS FOR 22 kV and 33 kV 50 Hz DISTRIBUTION SYSTEMS
WITH ABILITY TO WITHSTAND SHORT CIRCUIT

Specification No. RTRN-047/2561

Approved date : 26/09/2561

Rev. No.: 1

Form No. -

Page 12 of 28

1c.16 Terminal markings and connection diagrams

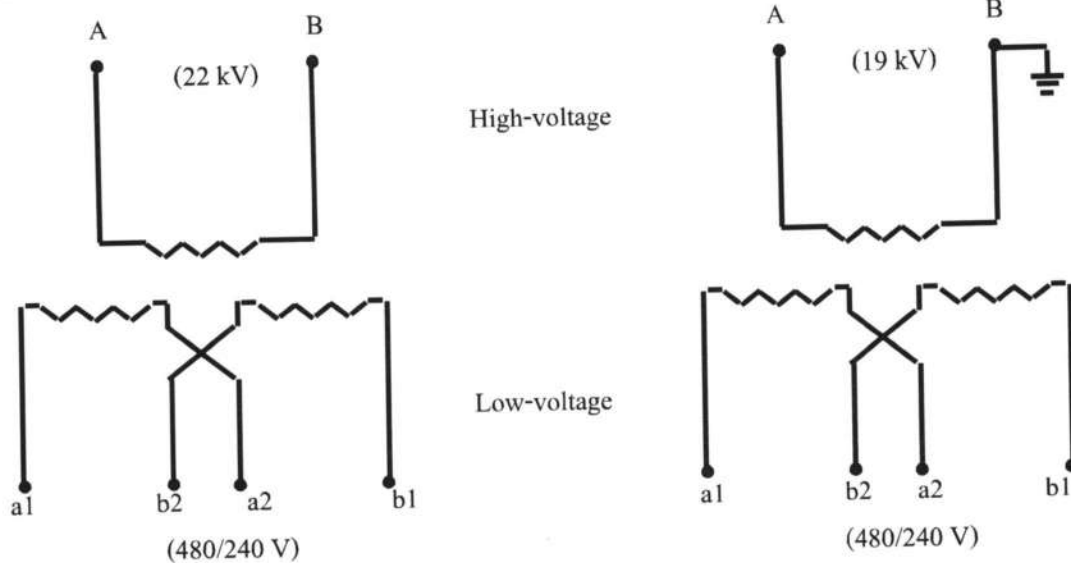

Figure 5 Terminal markings and connection diagrams

The symbols, A, B, a₁, a₂, b₁, and b₂, shall be durable marked on transformer tank beside bushings consequently. The height of the symbols shall not less than 30 mm.

Mark by sticker is not accepted.

1c.17 Mass

Mass of complete transformer with oil and accessories shall not be more than 1,000 kg.

Tolerance of the mass of proposed complete transformers with oil shall be within ± 5 percent of the declared mass of transformer which passed type test given by the bidders in 2a Performance data and guarantee of single-phase transformer (Page 25 of 28) but the maximum mass shall not exceed 1,000 kg.

If the mass of complete transformers with oil more than ± 5 percent of the declared mass or exceed the above allowable mass, the transformers shall be rejected.

1d Packing

For transformers manufactured outside the territories of Thailand, one (1) transformer or two (2) transformers shall be seaworthy packed in an export crate or wooden case which will not be returned.

For transformers manufactured within the territories of Thailand, one (1) transformer or two (2) transformers shall be packed in a crate or wooden case which will not be returned.

Each crate or wooden case shall be strong enough for stacking over with at least another one.

If the crate or wooden case is made of rubber wood (Yang-para), the wooden parts shall be treated with wood preservative. The details of wood treatment shall be described.

1e Tests and test reports

1e.1 Routine test

Each transformer shall pass the manufacturer's standard routine tests, and also pass the following tests in accordance with the relevant standards:

- (1) Measurement of winding resistance (IEC 60076-1)
- (2) Measurement of voltage ratio and check of phase displacement (IEC 60076-1)
- (3) Measurement of short-circuit impedance and load loss (IEC 60076-1)
- (4) Measurement of no-load loss and current (IEC 60076-1)
- (5) Dielectric routine tests (IEC 60076-1 and IEC60076-3)

The Item offered without submitting the list of routine test shall be rejected.

1e.2 Type test and Short-circuit withstand test

The following type tests shall be in accordance with the relevant standards:

- (1) Temperature-rise test (IEC 60076-2)
- (2) Dielectric type tests (IEC 60076-1 and IEC 60076-3)
- (3) Measurement of no-load loss and current at 90 % and 110 % of rated voltage (IEC 60076-1)
- (4) Short-circuit withstand test (IEC 60076-5)

Type test and short-circuit withstand test shall be made on only one (1) unit of each rating.

The transformers shall be passed all items of the type test and short-circuit withstand test, conducted or inspected by one (1) acknowledged independent testing laboratory according to **1e.3 Acknowledged independent testing laboratories** and the test result shall be included in one (1) test report.

The test report shall be issued or approved by the same acknowledged independent testing laboratory according to **1e.3 Acknowledged independent testing laboratories**, otherwise will be rejected.

The bidders have to submit the type test and short-circuit withstand test report with the bid.

The type test and short-circuit withstand test report of the transformers which are conducted or inspected by Thailand's national laboratories/institutes shall be valid within five (5) years count from the issued date in the test reports to the bid closing date.

For the type test and short-circuit withstand test report of the transformers which are conducted or inspected by laboratories/institutes, with in other countries shall be valid within ten (10) years count from the issued date in the test reports to the bid closing date.



PROVINCIAL ELECTRICITY AUTHORITY

TECHNICAL SPECIFICATION DIVISION

SINGLE-PHASE TRANSFORMERS FOR 22 kV and 33 kV 50 Hz DISTRIBUTION SYSTEMS WITH ABILITY TO WITHSTAND SHORT CIRCUIT

Specification No. RTRN-047/2561

Approved date : 26/09/2561

Rev. No.: 1

Form No. -

Page 14 of 28

PEA will also accept other documents instead of the type test and short-circuit withstand test reports in the following conditions:

- (1) In case the proposed transformer has been supplied to PEA and get the order from PEA's Procurement Department or Substation Work Department or Transmission and Distribution System Work Department (from PEA's head office), the Purchase Order (PO) or Contract with List of suppliers or Proposal form can be submitted, or
- (2) In case the proposed transformer has been registered for PEA Product Acceptance, the not-expired registration certificate counted to the bid closing date can be submitted, or
- (3) In case the proposed transformer has been registered for Product lists for substation turnkey project, the not-expired registration certificate counted to the bid closing date can be submitted instead

However the document in case (1), (2) and (3) shall be proved that the transformer specified in the PO or Contract with List of suppliers or Proposal form or registration certificate shall be the same product, type/model and all ratings as the proposed transformer for this bid.

The cost of all tests and reports shall be borne by the bidders/manufacturers/contractor.

1e.2.1 Short-circuit withstand test criteria

The transformers shall be designed and constructed to withstand without damage by the thermal and dynamic effects of the external short circuit in accordance with the IEC 60076-5.

The duration of the current I to be used for the calculation of the thermal ability to withstand short circuit shall be 2 s and the initial temperature for calculation shall be 105°C.

The ability to withstand the dynamic short circuit shall be demonstrated by test, comparison method is not acceptable. Test procedure of short-circuit withstand test shall be according to **1e.2.2 Test procedure of Type test and Short-circuit withstand test.**

The total number of tests shall be three made in a different position of the tap-changer according to IEC 60076-5. The duration of each test shall be 0.5 s

The bidders have to submit the short circuit test report of the identical transformers (purchased transformer) with the bid, otherwise shall be not accepted.

1e.2.2 Test procedure of Type test and Short-circuit withstand test

Each transformer, as delineated by its own unique serial number, is required to pass a complete type test and short-circuit withstand test following the procedures listed below:

- (1) Prior to short circuit testing, each individual transformer must pass the routine test, measurement of no-load loss and current at 90 % and 110 % of rated voltage and temperature-rise tests. Criteria for the temperature-rise test is presented in **1c.7 "Limits of temperature-rise"**



PROVINCIAL ELECTRICITY AUTHORITY

TECHNICAL SPECIFICATION DIVISION

SINGLE-PHASE TRANSFORMERS FOR 22 kV and 33 kV 50 Hz DISTRIBUTION SYSTEMS

WITH ABILITY TO WITHSTAND SHORT CIRCUIT

Specification No. RTRN-047/2561

Approved date : 26/09/2561

Rev. No.: 1

Form No. -

Page 15 of 28

- (2) Upon successfully passing the temperature-rise test, each transformer must then successfully pass a short circuit withstand test. The test circuit of short circuit withstand test shall be connected in 240 V position.
- (3) Finally, lightning impulse shall be tested and all the routine tests including measurement of no-load loss and current at 90 % and 110 % of rated voltage shall be repeated. Each transformer shall pass the routine test, measurement of no-load loss and current at 90 % and 110 % of rated voltage and lightning impulse test.

The impulse test sequence is applied to each of line terminal of the tested winding in succession. The other line terminals of the transformer shall be earthed directly or through an impedance.

If the laboratories intend to use PEA's power system as power supply for the short-circuit withstand testing, the transformer's manufacturer or the laboratories shall submit technical documents of the test such as test procedure, test circuit diagram, test and protection equipment, testing date and calculation of voltage drop in PEA's power system caused by the test to PEA for consideration and approval before the tests are proceeded.

It is responsible of the laboratories to compensate all failure or damage occurred to PEA's power system caused by the test.

PEA reserves the right to send representatives to witness the test.

The cost of all tests and reports shall be borne by the bidders/manufacturers/contractor.

1e.3 Acknowledged testing laboratories

The type test and short-circuit withstand test shall be conducted or inspected by the acknowledged testing laboratories/institutes as follows:

- (1) Laboratories/institutes which are members of the Short-circuit Testing Liaison (STL) or independent laboratories/institutes which are accredited according to TIS 17025 or ISO/IEC 17025 with the scope of accreditation covered the relevant test items, standards and equipment. The certification and scope of accreditation of the independent laboratories/institutes shall be submitted with the bid for consideration.

The bidders or manufacturers who are accredited according to TIS 17025 or ISO/IEC 17025 preferring to carry out the type tests and short-circuit withstand test of the transformers with the laboratories or by the manufacturers themselves, the tests shall be inspected by Thailand's national laboratories, institutes, universities and electric utilities in (2) and other laboratories, institutes, universities or electric utilities approved by PEA.

- (2) Thailand's national laboratories, institutes, universities and electric utilities, as follow:
 - Electricity Generating Authority of Thailand (EGAT)



PROVINCIAL ELECTRICITY AUTHORITY

TECHNICAL SPECIFICATION DIVISION

SINGLE-PHASE TRANSFORMERS FOR 22 kV and 33 kV 50 Hz DISTRIBUTION SYSTEMS

WITH ABILITY TO WITHSTAND SHORT CIRCUIT

Specification No. RTRN-047/2561

Approved date : 26/09/2561

Rev. No.: 1

Form No. -

Page 16 of 28

- (3) Other laboratories, institutes, universities or electric utilities approved by PEA. In this case, the detail of the test facilities of the laboratories shall be submitted to PEA for approval before proceeding the tests and before the bid closing date. PEA reserves the right to send representatives to inspect and witness the tests with the cost of the bidders or manufacturers.

1e.4 Information in the Test report

The minimum information of the transformers in the type test and short-circuit withstand test report shall be the following items:

1. Transformer information

- (1) Manufacturer's name
- (2) Model
- (3) Manufacturer's serial number
- (4) Number of phase
- (5) Rated voltage of the high-voltage winding
- (6) Rated voltage of the low-voltage winding
- (7) Rated voltage ratio
- (8) Rated frequency
- (9) Rated power
- (10) Rated current of the high-voltage winding
- (11) Rated current of the low-voltage winding
- (12) Short-circuit impedance at 75°C
- (13) Connection symbol
- (14) Cooling method
- (15) Total mass
- (16) Mass of core and winding
- (17) Oil quantity
- (18) Highest voltage for equipment applicable the high-voltage winding
- (19) Highest voltage for equipment applicable the low-voltage winding
- (20) Rated insulation level
- (21) Type of construction
- (22) High-voltage winding type and material
- (23) Low-voltage winding type and material
- (24) Cross-section of the conductor in the high-voltage winding
- (25) Cross-section of the conductor in the low-voltage winding

- (26) Number of strands per turn of high voltage winding
- (27) Number of strands per turn of low voltage winding
- (28) Number of strands radially across the layer (for all turns) of high voltage winding
- (29) Number of strands radially across the layer (for all turns) of low voltage winding
- (30) Total number of turns per phase
- (31) Number of turns of each tap

2. Drawing of transformers

- (1) Overall dimensions of transformer
- (2) Tank dimension
- (3) Drawing of cross section area of core
- (4) Drawing of active part
- (5) Drawing of core and coil as shown the detail and dimension according to **Figure 6**

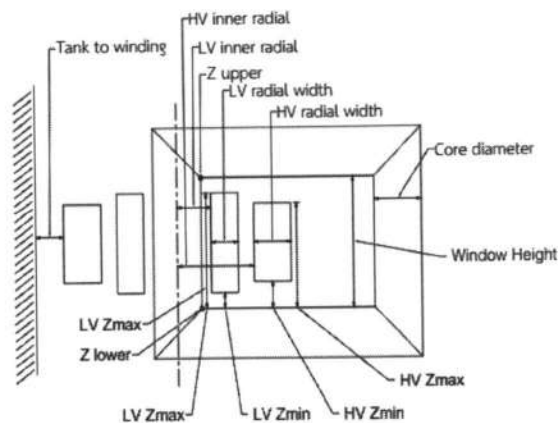

Figure 6: Core and coil constructions.

3. Photograph of transformers

The color photograph which reveal transformer construction for out-of-tank inspection before and after short-circuit withstand test shall be in the short-circuit withstand test report.

In case the information in the reports are not completed according to the above requirement, the bidders will be rejected.

1e.5 Acceptance test items and acceptance test procedures

1e.5.1 Acceptance test items

The sample of transformers shall pass the following tests in accordance with the IEC 60076 and IEC 60156 standards.

- (1) Measurement of winding resistance (IEC 60076-1)
- (2) Measurement of voltage ratio and check of phase displacement (IEC 60076-1)
- (3) Measurement of short-circuit impedance and load loss (IEC 60076-1)
- (4) Measurement of no-load loss and current (IEC 60076-1)
- (5) Dielectric routine tests (IEC 60076-3)
- (6) Oil dielectric breakdown voltage test (IEC 60156)
- (7) Temperature-rise test (IEC 60076-2)⁽¹⁾
- (8) Lightning impulse test (IEC 60076-3)⁽¹⁾
- (9) Short-circuit withstand test (IEC 60076-5)⁽²⁾
- (10) Dry film thickness test, the dry film thickness test procedure shall be according to **1c.11.1**

Painting system

Note

⁽¹⁾ The Items (7) and (8) shall be tested on one (1) unit for each contract at the PEA laboratory or Acknowledged independent laboratories approved by PEA as specified in **1e.3 Acknowledged independent testing laboratories** or manufacturer laboratories depending on PEA's acceptance committee

⁽²⁾ The Items (9) shall be tested on one (1) unit for each contract at Acknowledged Independent laboratories depend on PEA's acceptance committee approved by PEA as specified in **1e.3 Acknowledged independent testing laboratories**.

Any transformers which are out-of-tank for inspection in short-circuit withstand test, the insulating oil shall be dehydration at manufacture's factory and oil dielectric breakdown voltage shall be retested. The report of oil dielectric breakdown voltage test shall be submitted to PEA before shipment/delivery, for each ordered transformer.

1e.5.2 Acceptance test procedures

PEA's acceptance committee and will select the sample of each lot, the number of transformer per lot according to **Table 6**. All sampling units shall be transported to PEA laboratory or Acknowledged independent laboratories for testing according to **1e.5.1 Acceptance test items**. The transportation shall be carried out by the contractor.

SINGLE-PHASE TRANSFORMERS FOR 22 kV and 33 kV 50 Hz DISTRIBUTION SYSTEMS
WITH ABILITY TO WITHSTAND SHORT CIRCUIT

Specification No. RTRN-047/2561

Approved date : 26/09/2561

Rev. No.: 1

Form No. -

Page 19 of 28

Table 6 The number of sample and criteria for consideration

Number of transformer per lot (Unit)	Sample size of transformers for acceptance test (Unit)	Maximum number of sample failing in the acceptance test (Unit)
2 to 15	2	0
16 to 25	3	0
26 to 90	5	0
91 to 150	8	0
151 to 500	13	1
More than 500	20	1

The number of failing units shall not more than the maximum number of failing sample in the acceptance test according to **Table 6**. Otherwise, the transformers in that lot shall be rejected.

In case of the failing units not more than the maximum number of failing sample in the acceptance test according to **Table 6**, the contractor has to take responsibility as following procedure.

- (1) The contractor has to recheck all delivered transformers in that lot and repair or fix the defective transformers in that lot.
- (2) The contractor shall analyze the problem and send the report to PEA's acceptance committee before the lot accepted.
- (3) The transformers which are repaired or fixed in that lot shall be retested only in the relevant test items according to **1e.5.1 Acceptance test items**.

After the test, the transformers shall be rebuilt completely by the contractor with free of charge and send back to PEA with the same amount of the samples.

1f Inspection

To ensure about the quality of transformers, the inspection shall be carried out by the PEA's representative (PEA's witness committee) at following two stages:

- Online anytime during receipt of raw material and manufacture/assembly whenever the PEA desires.
- At finished stage i.e. transformers are fully assembled and are ready for dispatch.



PROVINCIAL ELECTRICITY AUTHORITY

TECHNICAL SPECIFICATION DIVISION

SINGLE-PHASE TRANSFORMERS FOR 22 kV and 33 kV 50 Hz DISTRIBUTION SYSTEMS WITH ABILITY TO WITHSTAND SHORT CIRCUIT

Specification No. RTRN-047/2561

Approved date : 26/09/2561

Rev. No.: 1

Form No. -

Page 20 of 28

C2 Material and packing data of the single-phase transformers

The bidders have to submit the following data and details of transformers and accessories with the bid:

2a Performance data and guarantee of the single-phase transformers (See pages 23 to 26 of 28)

2b Drawing of inside tank and overall transformer with dimensions in mm showing of particulars of normal construction details.

2c Drawings, with dimensions in mm, of the following accessories:

1. HV and LV bushings
2. Terminal connectors on HV and LV bushings with description of materials used for the component parts
3. Nameplate with connection diagram
4. Valve, showing the internal construction
5. Earthing terminal connector
6. Bracket for surge arrester
7. Earthing terminal for surge arrester
8. Lifting lug
9. Supporting lugs
10. Compression type of cable lug
11. Accessories according to manufacturer's design, if any

2d Catalogues and/or drawings with details of the following accessories:

1. Bird guard
2. Core
3. HV and LV Winding
4. Off load tap changer
5. Insulation paper
6. Gaskets
7. Oil drain vale
8. Accessories according to manufacturer's design, if any

2e Dry film thickness test report

2f Type test and Short-circuit withstand test report

2g List of routine test



PROVINCIAL ELECTRICITY AUTHORITY

TECHNICAL SPECIFICATION DIVISION

SINGLE-PHASE TRANSFORMERS FOR 22 kV and 33 kV 50 Hz DISTRIBUTION SYSTEMS WITH ABILITY TO WITHSTAND SHORT CIRCUIT

Specification No. RTRN-047/2561

Approved date : 26/09/2561

Rev. No.: 1

Form No. -

Page 21 of 28

2h Drawings of core and coil construction

2i Specifications of transformer oil and test report

2j HV and LV Bushing test report

2k Others necessary information in order to show that the special test report can prove the performance of the proposed transformers.

2l Bidders shall propose and quote for recommended spare part lists with separate price for each offered item (e.g., bushings)

2m Packing details

Packing method (shown by drawing(s), and describe packing materials).

Number of transformers in one (1) crate or wooden case (one or two).

Overall dimensions (L x W x H) of each crate or wooden case in cm.

Volume of each crate or wooden case in m³.

Gross weight of each crate or wooden case in kg.

Number of crates or wooden cases.

2n Critical documents of the transformers (See page 22 of 28)

The lists of documents shall be fulfilled and submitted with the bid.



การไฟฟ้ชาลวงภูมิภาค
PROVINCIAL ELECTRICITY AUTHORITY

PROVINCIAL ELECTRICITY AUTHORITY

TECHNICAL SPECIFICATION DIVISION

SINGLE-PHASE TRANSFORMERS FOR 22 kV and 33 kV 50 Hz DISTRIBUTION SYSTEMS

WITH ABILITY TO WITHSTAND SHORT CIRCUIT

Specification No. RTRN-047/2561

Approved date : 26/09/2561

Rev. No.: 1

Form No. -

Page 22 of 28

The Critical documents of the transformers

No.	Required documents	Proposed technical document	Reference document (Page/Item)
1	HV and LV Bushing test report	<input type="checkbox"/> Yes <input type="checkbox"/> No	
2	Dry film thickness test report	<input type="checkbox"/> Yes <input type="checkbox"/> No	
3	List of routine test report	<input type="checkbox"/> Yes <input type="checkbox"/> No	
4	Type test and Short-circuit withstand test report, or	<input type="checkbox"/> Yes <input type="checkbox"/> No	
	The copy of previous Purchase Order (PO) or Contract with List of suppliers or Proposal form, or	<input type="checkbox"/> Yes <input type="checkbox"/> No	
	PEA Product Acceptance registration certificate, or	<input type="checkbox"/> Yes <input type="checkbox"/> No	
	Product lists registration certificate	<input type="checkbox"/> Yes <input type="checkbox"/> No	
5	The TIS 17025 or ISO/IEC 17025 certification and scope of accreditation of the independent laboratories/institutes (in case the independent laboratories/institutes are accredited according to TIS 17025 or ISO/IEC 17025)	<input type="checkbox"/> Yes <input type="checkbox"/> No	
6	Performance data and guarantee of the single-phase transformers (page 23 to 26 of 28)	<input type="checkbox"/> Yes <input type="checkbox"/> No	
7	Drawing of inside tank and overall transformer with dimensions in mm showing of particulars of normal construction details.	<input type="checkbox"/> Yes <input type="checkbox"/> No	
8	Drawings, with dimensions in mm, according to 2c	<input type="checkbox"/> Yes <input type="checkbox"/> No	
9	Catalogues and/or drawings with details, according to 2d	<input type="checkbox"/> Yes <input type="checkbox"/> No	
10	Drawing of core and coil construction according to 2h	<input type="checkbox"/> Yes <input type="checkbox"/> No	
11	Specifications of transformer oil and test report according to 2i	<input type="checkbox"/> Yes <input type="checkbox"/> No	
12	Packing detail(s) according to 2m	<input type="checkbox"/> Yes <input type="checkbox"/> No	

The items offered without submitting the critical documents shall be rejected



การไฟฟ้าส่วนภูมิภาค
PROVINCIAL ELECTRICITY AUTHORITY

PROVINCIAL ELECTRICITY AUTHORITY

TECHNICAL SPECIFICATION DIVISION

SINGLE-PHASE TRANSFORMERS FOR 22 kV and 33 kV 50 Hz DISTRIBUTION SYSTEMS

WITH ABILITY TO WITHSTAND SHORT CIRCUIT

Specification No. RTRN-047/2561

Approved date : 26/09/2561

Rev. No.: 1

Form No. -

Page 23 of 28

Invitation to Bid No.:

2a Performance data and guarantee of the single-phase transformer

Item

Manufacturer's name and country of origin		
Type or model		
Applied standard		
Rated output	kVA	
Rated frequency	Hz	
Polarity	-	
Rated primary voltage	V	
Rated secondary voltage	V	
Operation duty : continuous operation (Type DB)	Yes/No	
Max. temperature rise of winding (at full load)	K	
Max. temperature rise of top oil (at full load)	K	
Primary tapping: off-circuit condition	Yes/No	
Number of steps of primary tapping	Steps	
Per cent of rated voltage of each tapping	%	
No-load current & Tolerance	% & %	&
Short-circuit impedance at 75°C & Tolerance	% & %	&
Losses , for each transformer unit		
- No-load loss plus positive tolerance	W	
- Load loss, plus positive tolerance, at 75°C	W	
Efficiency in %, at 75°C and at load :		
- 1/2 of rated power and P.F. = 1.0	%	
- 1 of rated power and P.F. = 1.0	%	
Voltage regulation at P.F. = 1.0	%	



การไฟฟ้าส่วนภูมิภาค
PROVINCIAL ELECTRICITY AUTHORITY

PROVINCIAL ELECTRICITY AUTHORITY

TECHNICAL SPECIFICATION DIVISION

SINGLE-PHASE TRANSFORMERS FOR 22 kV and 33 kV 50 Hz DISTRIBUTION SYSTEMS

WITH ABILITY TO WITHSTAND SHORT CIRCUIT

Specification No. RTRN-047/2561

Approved date : 26/09/2561

Rev. No.: 1

Form No. -

Page 24 of 28

Item

		HV	LV
Bushings			
- Manufacturer's name	-		
- Country of origin	-		
- Applied standard	-		
- Rated current	A		
- BIL	kV, peak		
- Low-frequency dry 1-minute test voltage	kV, r.m.s.		
- Low-frequency wet 10-second test voltage	kV, r.m.s.		
- Colour of glazing	-		
Terminal connectors on HV and LV bushings			
- Manufacturer's name	-		
- For aluminium conductor diameter range (HV side)	mm		
- For copper conductor diameter range (LV side)	mm		
- For aluminium conductor diameter range (LV side)	mm		
- Number of circuits, take-off (LV side)	Circuits		
- Terminal pads are according to PEA's Drawing No. SA4-015/45001	Yes/No		
Winding		HV	LV
- Manufacturer's name (the bidders have to quote not more than three (3) manufacturers)	-		
- Country of origin	-		
- Material : copper	Yes/No		
- Type of enamel or insulating material of wire	-		
- Size of wire			
- for HV side (diameter)	mm		
- for LV side (dimension)	mm x mm		
- Resistance per phase at 75°C	Ohms		
- Full-wave impulse withstand voltage, or BIL	kV, peak		
- Power-frequency test voltage, 1 min	kV, r.m.s.		
- Construction of winding	-		



การไฟฟ้าส่วนภูมิภาค
PROVINCIAL ELECTRICITY AUTHORITY

PROVINCIAL ELECTRICITY AUTHORITY

TECHNICAL SPECIFICATION DIVISION

SINGLE-PHASE TRANSFORMERS FOR 22 kV and 33 kV 50 Hz DISTRIBUTION SYSTEMS

WITH ABILITY TO WITHSTAND SHORT CIRCUIT

Specification No. RTRN-047/2561

Approved date : 26/09/2561

Rev. No.: 1

Form No. -

Page 25 of 28

Item

- Current density	A/mm ²	
- Number of layer per coil	-	
- Number of turns of each coil in tap No.3	Turns	
- Number of turns of each tapping position	Turns	
- Total turns of each coil	Turns	
Core		
- Manufacturer's name (the bidders have to quote not more than three (3) manufacturers)		
- Country of origin		
Method of cooling	-	
Total cooling surface	m ²	
Brand of oil used for initial filling	-	
Completely assembled transformer shall withstand, without permanent deformation, a maximum pressure of	kg/cm ²	
Colour of tank : grey (RAL 7036)	Yes/No	
Tank finish conforms to PEA's requirement	Yes/No	
Quantity of oil filling	liter	
Mass of core	kg	
Mass of winding	kg	
Mass of the part liftable from tank	kg	
Mass of complete transformer with oil	kg	
Terminal markings and connections conform to PEA's requirement	Yes/No	
Tank		
- Thickness of side wall	mm	
- Thickness of top plate	mm	
- Thickness of bottom plate	mm	
Internal dimensions		
- Height	mm	
- Width	mm	
- Depth	mm	



PROVINCIAL ELECTRICITY AUTHORITY

TECHNICAL SPECIFICATION DIVISION

SINGLE-PHASE TRANSFORMERS FOR 22 kV and 33 kV 50 Hz DISTRIBUTION SYSTEMS

WITH ABILITY TO WITHSTAND SHORT CIRCUIT

Specification No. RTRN-047/2561

Approved date : 26/09/2561

Rev. No.: 1

Form No. -

Page 26 of 28

Item

Dimensions of transformer		
- Overall height	mm	
- Overall width	mm	
- Overall depth	mm	
- Height over cover	mm	
Total dry film thickness	μm	
Fin		
- Fin radiators or Corrugated thickness	mm	
- Dimension of each fin (LxBxT)	mm	
- Number of Fins per radiator	-	
- Total number of fin	-	
Bushing clearance		
- Please fill in the shortest of clearance		
- LV to earth	mm	
- HV to earth	mm	
- Between LV bushing	mm	
- Between HV bushing	mm	
Detail documents of Item 1 on Page 27 of 28 shall be sent to PEA before shipment/delivery	Yes/No	
X/R ratio	-	
Rated short circuit current and withstanding duration		
- Current	kA	
- Duration	s	
Duration of overload		
- 25% overload	Minutes	
- 50% overload	Minutes	
Magnetic flux density	Tesla	
Other :		



PROVINCIAL ELECTRICITY AUTHORITY

TECHNICAL SPECIFICATION DIVISION

SINGLE-PHASE TRANSFORMERS FOR 22 kV and 33 kV 50 Hz DISTRIBUTION SYSTEMS

WITH ABILITY TO WITHSTAND SHORT CIRCUIT

Specification No. RTRN-047/2561

Approved date : 26/09/2561

Rev. No.: 1

Form No. -

Page 27 of 28

Note : Conditions for documentation and consideration

1. The Contractor has to supply the following documents in English and/or Thai, before shipment/delivery, for each ordered transformer:

- 1.1 Report of routine tests
- 1.2 Number of turns of each winding, each coil, and each tapping position
- 1.3 Mass of HV windings and of LV windings
- 1.4 Type of enamel, temperature class, and size of the enameled wire
- 1.5 Information for Reference (only one (1) unit per contract). The following information for each transformer shall be submitted for maintenance purpose.
 - Coil height for each winding before assembly and after complete assembly.
 - Torque value on clamping bolts or pressure for each winding before assembly and after complete assembly.
 - Photograph of each coil for each phase and photograph of core and coils assembly. The photograph of each coil shall be taken from the final production process before placing to the core, top view and front view shall be provided. The photograph of core and coils assembly shall be taken just prior to place the completed core and coils assembly into the tank, top view, front view, right view, left view and rear view shall be provided for complete set of photographs. All photographs shall be 216 mm (8-1/2 in) by 280 mm (11 in) gloss prints properly labelled relevant to the view taken.
- 1.6 Invoice and Test report of the following material and accessories used in each supply shall be submitted.
 - Transformer oil
 - Silicon steel
 - Copper conductor
 - Insulation paper and pressboard
 - Pressure relief
 - Gaskets
 - Bushing
 - Transformer supervisory equipment



PROVINCIAL ELECTRICITY AUTHORITY

TECHNICAL SPECIFICATION DIVISION

SINGLE-PHASE TRANSFORMERS FOR 22 kV and 33 kV 50 Hz DISTRIBUTION SYSTEMS

WITH ABILITY TO WITHSTAND SHORT CIRCUIT

Specification No. RTRN-047/2561

Approved date : 26/09/2561

Rev. No.: 1

Form No. -

Page 28 of 28

The above documents shall be sent to the following address:

Transformer Division
Provincial Electricity Authority
200 Ngam Wong Wan Road, Chatuchak
Bangkok Metropolis 10900
Thailand

2. If the material and packing data given by bidders, which are mentioned on Page 20 to 21 of 28, are estimated or approximate, the bid may be rejected.
3. Delivery time is also one of the important factors to be considered.
4. Partial shipment/delivery is allowed.



PROVINCIAL ELECTRICITY AUTHORITY
TECHNICAL SPECIFICATION DIVISION

Specification No. RTRN-047/2561 : SINGLE-PHASE TRANSFORMERS FOR 22 kV and 33 kV 50 Hz
DISTRIBUTION SYSTEMS WITH ABILITY TO WITHSTAND
SHORT CIRCUIT

Page 1 of 1

C3 Schedule of detailed requirement

Item	PEA Material No.	Quantity	Description
1	1050000011	360 set(s)	30 kVA, single-phase transformer, 22000-480/240V, withstand short-circuit
2	1050000206	set(s)	30 kVA, single-phase transformer, 19000-480/240V, withstand short-circuit
			<u>Note :</u> Enclosed Drawings No. SA2-015/26028, SA4-015/45001 and SA4-015/50007
	I		



**PROVINCIAL ELECTRICITY AUTHORITY
TECHNICAL SPECIFICATION DIVISION**

ਪ੍ਰਾਂਤੀਕ ਬਿਜਲੀ ਅਥਾਰਿਟੀ
PROVINCIAL ELECTRICITY AUTHORITY

Specification No. RTRN-047/2561 : SINGLE-PHASE TRANSFORMERS FOR 22 kV and 33 kV 50 Hz DISTRIBUTION SYSTEMS

WITH ABILITY TO WITHSTAND SHORT CIRCUIT

C4 Price schedule

Invitation to Bid No. ਪ੍ਰ.ਬ.ਸੇ.ਸੰ. (੧੯.) ਏ.ਬ.13 |2561

Manufacturer :
Country of origin :
Trade-mark :

Item	PEA Material No.	Catalogue No.	Description	Quantity	Unit Cost (See details & conditions attached)	Total Cost (See details & conditions attached)
1	1050000011		30 kVA, single-phase transformer, 22000-480/240V, withstand short-circuit	360 set(s)		
2	1050000206		30 kVA, single-phase transformer, 19000-480/240V, withstand short-circuit	set(s)		

PRELIMINARY

การประกอบเหล็ก
ASSEMBLY NO.

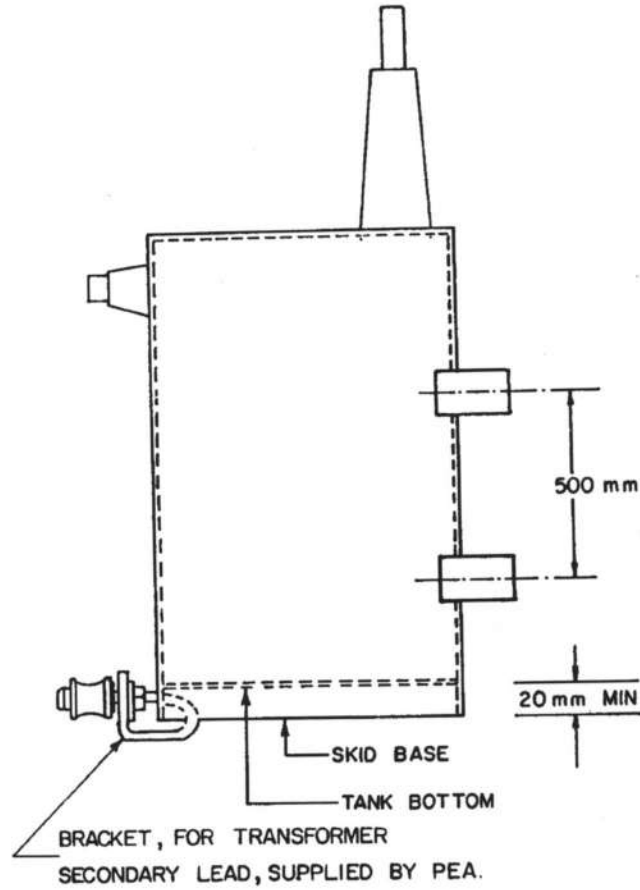

กองวิศวกรรมไฟฟ้าและเครื่องกล ฝ่ายวิศวกรรม	การไฟฟ้าส่วนภูมิภาค	ใช้งานแบบ
ผู้เขียน พ.ย. พ.ศ. ๒๕๖๓ ผู้สำรวจ 3๐๓ ย.พ. ผู้ให้คำแนะนำ/ความเห็น ผู้ดำเนินการก่อสร้าง ผู้ควบคุมการส่งมอบ	ผู้ทำการ	ถูกแทนโดยแบบ
รองผู้ว่าการฝ่ายเทคนิค	FIXING OF BRACKET FOR TRANSFORMER SECONDARY LEAD	เดือนที่ ๒๑ พ.พ. ๒๕๒๖
		ทัศนคติ
		วัสดุอื่น
		วัสดุบางส่วน
		หมายเลขที่ SA2-015/26028
		แผ่นที่ 1 ของจำนวน 1 แผ่น

PRELIMINARY

การประกอบเลขที่
ASSEMBLY NO.

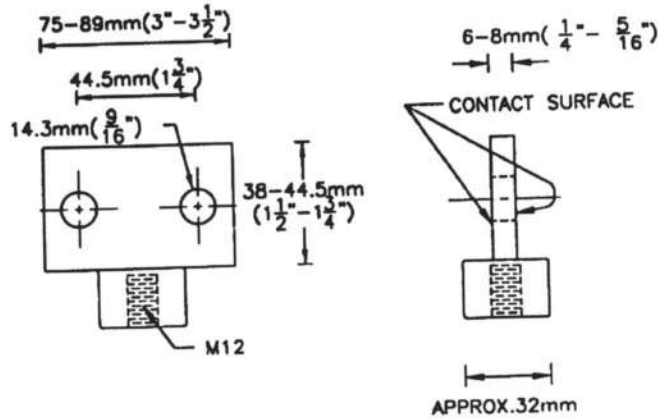
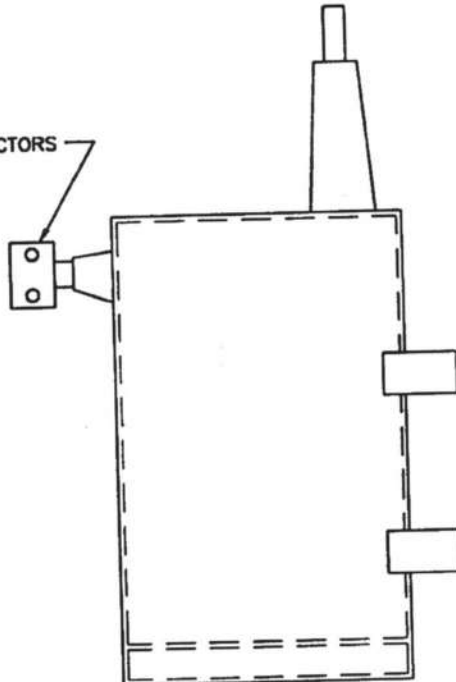

FIGURE 1

L.V. TERMINAL PAD CONNECTORS
IN VERTICAL



NOTES :

ALL DIMENSION ARE IN mm

กองมาตรฐานระบบไฟฟ้า ฝ่ายมาตรฐานและความปลอดภัย	การไฟฟ้าส่วนภูมิภาค	ใช้แทนแบบ ถูกแทนโดยแบบ
ผู้เขียน <i>Supphakit Boonchanog</i> ผู้สำรวจ วิศวกร <i>97</i> หัวหน้าแผนก ผู้อำนวยการกอง <i>11/2</i> ผู้อำนวยการฝ่าย <i>11/2</i>	ผู้ว่าการ รายละเอียดของข้อต่อสายแรงต่ำสำหรับ หม้อแปลงไฟฟ้าหนึ่งเฟส 10-50 kVA	เขียนเสร็จวันที่ 11. ม.ค. 2545 แก้แบบวันที่ มิติเป็น มิลลิเมตร มาตรฐาน
รองผู้ว่าการวางแผน และพัฒนาระบบไฟฟ้า	DETAIL OF L.V. TERMINAL PADS FOR 10-50 kVA SINGLE-PHASE TRANSFORMER	แบบเลขที่ SA4-015/45001 แผ่นที่ 1 ของจำนวน 1 แผ่น

PRELIMINARY

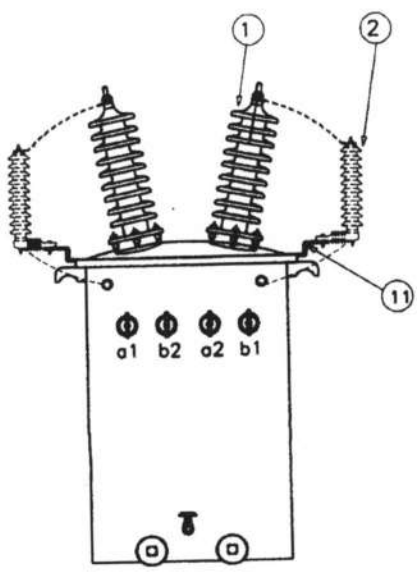

For 22 kV

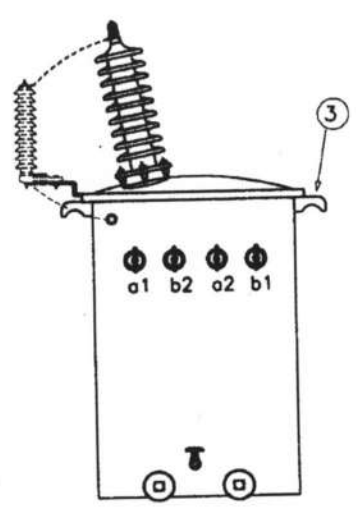

For 19 kV

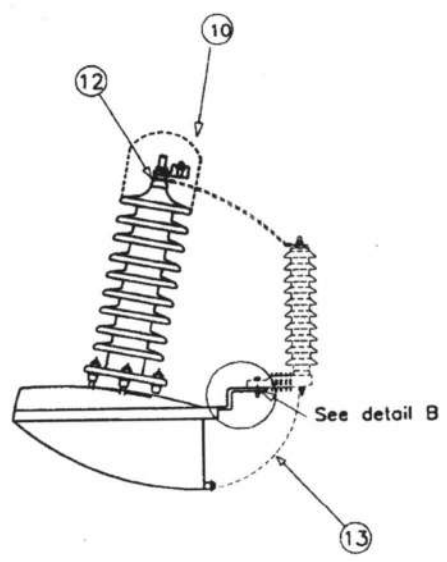
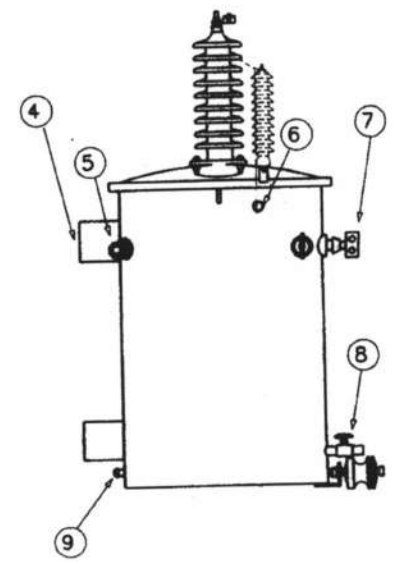

NO.	DESCRIPTION
1.	HV Bushing with terminal connector
2.	Surge arrester(Polymer housing type)
3.	Lifting lugs
4.	Support lugs
5.	Off-load tap changer
6.	Earthing terminal for surge arrester (See detail A)
7.	LV Bushing with terminal connector
8.	Oil drain valve
9.	Earthing terminal
10.	Bird guard cap
11.	Bracket for surge arrester
12.	Cable lug
13.	Flexible copper insulated ground lead

Note :

- Surge arrester, line lead and ground lead, supplied by PEA
- Earthing terminal for surge arrester shall be eye-bolt type or socket type.
- Position of earthing terminal for surge arrester shall be suitable for flexible copper insulated ground lead size 16 sq.mm, 430 mm long.
- Not to scale

กองมาตรฐานระบบไฟฟ้า ฝ่ายมาตรฐานและความปลอดภัย	การไฟฟ้าส่วนภูมิภาค	ใช้แทนแบบ..... ถูกแทนโดยแบบ..... เขียนเสร็จวันที่ 18 ก.พ. 2552 แก้แบบวันที่..... มิติเป็น..... มาตราส่วน.....
ผู้เขียน... น.ก.ต.ต. เพ็ญดา..... ผู้สำรวจ..... วิศวกร..... หัวหน้าแผนก..... ผู้อำนวยการกอง..... ผู้อำนวยการฝ่าย.....	ผู้ว่าการ..... ส่วนประกอบหม้อแปลง 1 เฟส พร้อมกับตัดกัฟฟ้าผ่า สำหรับหม้อแปลงขนาด 10 kVA ถึง 50 kVA	
รองผู้ว่าการ	DETAIL OF 1 PHASE TRANSFORMER 10 kVA TO 50 kVA WITH SURGE ARRESTER	แบบเลขที่ SA4-015/50007. แผ่นที่ 1. ของจำนวน 3. แผ่น

Detail A :

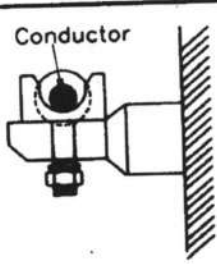
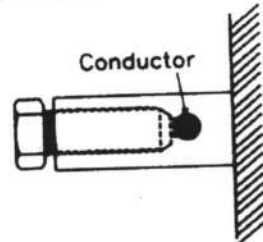
Type of earthing terminal for surge arrester	
 <p>Conductor</p> <p><u>eye-bolt type earthing terminal</u></p>	 <p>Conductor</p> <p><u>socket type earthing terminal</u></p>
<p><u>Description</u></p> <p>Eye-bolt type earthing terminal shall be with eye-bolt type connector suitable for flexible copper insulated ground lead size 16 sq.mm ; complete with lock washer of stainless steel or better</p>	<p><u>Description</u></p> <p>Socket type earthing terminal shall be with socket suitable for flexible copper insulated ground lead size 16 sq.mm ; complete with bolt of stainless steel or better for lock conductor</p>

กองมาตรฐานระบบไฟฟ้า ฝ่ายมาตรฐานและความปลอดภัย	<h2>การไฟฟ้าส่วนภูมิภาค</h2>	ใช้แทนแบบ..... ถูกแทนโดยแบบ..... เขียนเสร็จวันที่ 18 ก.พ. 2552 แกบวันวันที่..... มิติเป็น..... มาตรฐาน.....
ผู้เขียน... มีนศักดิ์ เพ็ญตา..... ผู้สำรวจ..... วิศวกร... <i>W. K.</i> หัวหน้าแผนก... <i>Donk</i> ผู้อำนวยการกอง..... ผู้อำนวยการฝ่าย.....	ผู้ว่าการ..... ส่วนประกอบหม้อแปลง 1 เฟส พร้อมติดตั้งค้ำฟ้า สำหรับหม้อแปลงขนาด 10 kVA ถึง 50 kVA	แบบเลขที่ SA4-015/50007 แผ่นที่ 2. ของจำนวน 3. แผ่น
รองผู้ว่าการ	DETAIL OF 1 PHASE TRANSFORMER 10 kVA TO 50 kVA WITH SURGE ARRESTER	

PRELIMINARY

Detail B :

Detail of mounting bracket for surge arrester

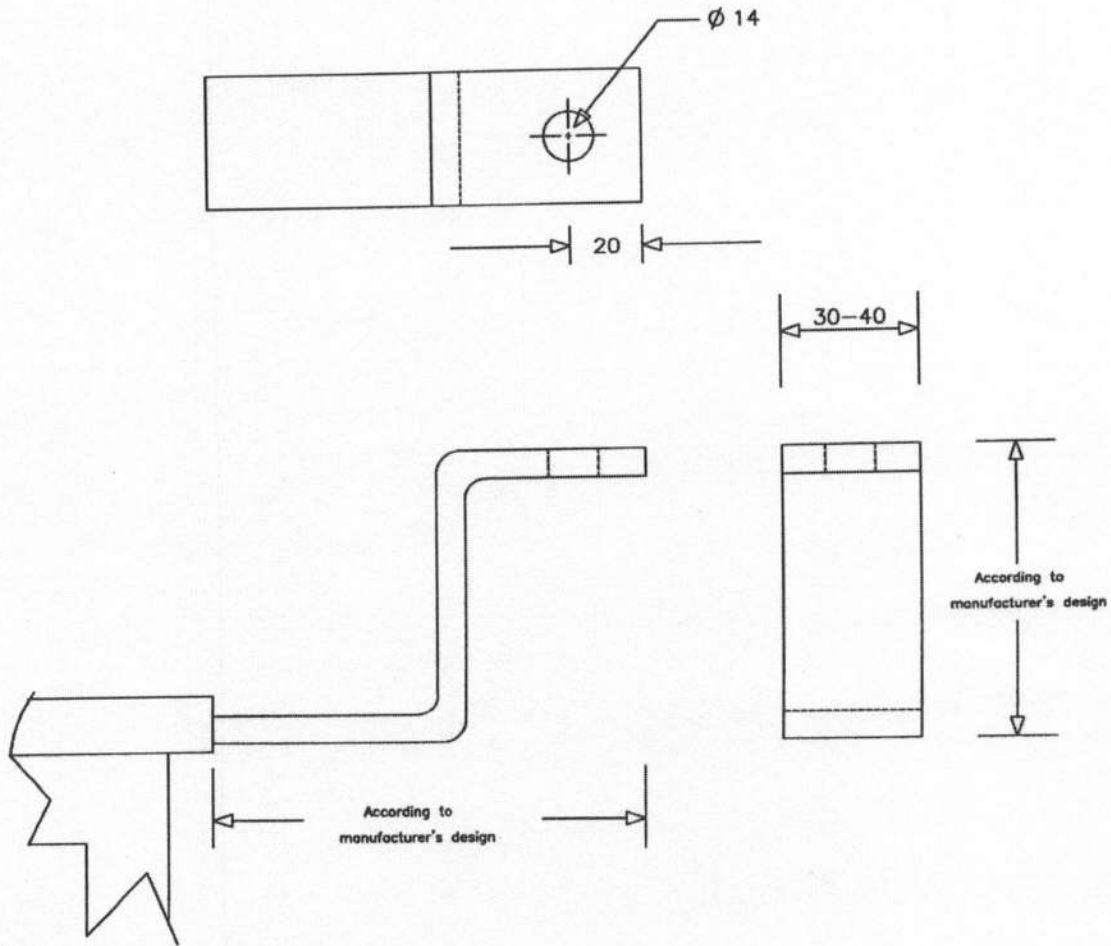

Note.

1. Material of mounting bracket shall be stainless steel or painted with RAL gray color. And paint system shall be system No. A.3.09, according to table A.3 ISO12944-5 which the total thickness not less than 200 um.
2. Shape and dimension of mounting bracket, unless specified shall be according to manufacturer's design.
3. The mounting bracket shall be designed to support up to 8 kg surge arrester.

กองข้อกำหนดทางเทคนิค ฝ่ายวิศวกรรม	การไฟฟ้าส่วนภูมิภาค	ใช้นั้นแบบ..... ถูกแทนโดยแบบ.....
ผู้เขียนมาตรฐาน... ผู้สำรวจ..... วิศวกร..... หัวหน้าแผนก..... ผู้อำนวยการกอง..... ผู้อำนวยการฝ่าย.....	ผู้ว่าการ..... ส่วนประกอบหม้อแปลง 1 เฟส พร้อมกักฟ้าผ่า สำหรับหม้อแปลงขนาด 30 kVA	เขียนเสร็จวันที่ 18 ก.พ. 2552 แก้มบววันที่ 3 ก.ย. 2561 ผลิตเป็น... มิลลิเมตร..... มาตรฐาน.....
รองผู้ว่าการ	DETAIL OF 1 PHASE TRANSFORMER 30 kVA WITH SURGE ARRESTER	แบบเลขที่ SA4-015/50007 แผ่นที่ 3 ของจำนวน 3 แผ่น