



PROVINCIAL ELECTRICITY AUTHORITY

TECHNICAL SPECIFICATION DIVISION

INSULATORS

Specification No.: -

Approved date: 2/12/2563

Rev. No.: -

Form No. -

Page 1 of 1

เอกสารเพิ่มเติมแนบท้ายรายละเอียดสเปค (Addendum) ประกอบการจัดซื้อลูกถ้วย

เอกสารเพิ่มเติมแนบท้ายรายละเอียดสเปคนี้ ใช้นับกับสเปคอ้างอิงเลขที่ RINS-002/2561 และสเปคอ้างอิงเลขที่ RINS-005/2551 เพื่อประกอบการจัดหาลูกถ้วย (Insulators)

"หากรายละเอียดสเปค หรือเอกสารเพิ่มเติมแนบท้ายรายละเอียดสเปค (Addendum) อันมีการกำหนดอายุของรายงานผลการทดสอบเฉพาะแบบ (Type and design test report) ไว้ให้กำหนดอายุของรายงานผลการทดสอบเฉพาะแบบดังกล่าว เริ่มมีผลบังคับใช้ตั้งแต่วันที่ 1 มกราคม 2566 เป็นต้นไป"



PROVINCIAL ELECTRICITY AUTHORITY

TECHNICAL SPECIFICATION DIVISION

INSULATORS

Specification No.: RINS-002/2561

Approved date: 21/05/2561

Rev. No.: 2

Form No. 01-1

Page 1 of 9

Invitation to Bid No. :

C Material, equipment, and specifications for INSULATORS

C1 General material and packing instructions

Additional to the general instructions, the following shall be observed :

1a Scope

These specifications cover insulators for overhead HV (up to 115 kV) and LV lines.

1b Standard

The insulators shall be manufactured and tested in accordance with the following standards:

Thai Industrial Standards (TIS)

TIS 227 - 2525	Spool-type porcelain insulators
TIS 279 - 2521	Pin-type porcelain insulators
TIS 280 - 2525	Strain-type porcelain insulators
TIS 354 - 2523	Suspension-type porcelain insulators
TIS 563 - 2528	Suspension-type toughened glass insulators
TIS 1077 - 2535	Line-post type porcelain insulators
TIS 1251 - 2537	Pin-post type porcelain insulators

American National Standards Institute (ANSI)

ANSI C29.1 - 1988	Test methods for electrical power insulators
ANSI C29.2A - 2013	Wet-process porcelain and toughened glass – distribution suspension type
ANSI C29.2B - 2013	Wet-process porcelain and toughened glass – transmission suspension type
ANSI C29.9 - 2017	Wet-process porcelain insulators – apparatus, post – type

International Electrotechnical Commission (IEC)

IEC 60383-1 -1993	Insulators for overhead lines with a nominal voltage above 1000 V – Part 1: Ceramic or glass insulator units for a.c. systems – Definitions, test methods and acceptance criteria
-------------------	---

And all other relevant standards, unless otherwise specified in these specifications.

PEA will accept the design/type test reports in accordance with the later edition of the above standards.

PEA will also accept the design/type test report in accordance with the previous edition of the above standards, if there is no significant change in any test items or no additional test item(s) compared with the above standards. On the other hand, if there is significant change in any test items or there are any additional test items, the previous edition type test report with the additional test report(s) of the significant change test item(s) and/or additional test item(s) will be also accepted.



PROVINCIAL ELECTRICITY AUTHORITY

TECHNICAL SPECIFICATION DIVISION

INSULATORS

Specification No.: RINS-002/2561

Approved date: 21/05/2561

Rev. No.: 2

Form No. 01-1

Page 2 of 9

1c Principal requirement

1c.1 General

The porcelain insulators shall be brown glazed.

The pin hole threads of the pin type insulators shall be zinc thimble according to TIS .

The insulator shells of suspension insulator of porcelain type shall be made of highest grade, dense, homogeneous, wet-process, high strength alumina porcelain.

The surface shells of suspension insulator of porcelain type exposed after the assembly shall be relatively smooth and free of imperfections.

The porcelain head of the suspension insulator shall be cylindrical headed with sand surfaces; the "dove tail" shaped head shall not be accepted.

For the line-post insulator and pin-post insulator, the porcelain part shall be factory-fixed with stud, washer, nut, and lock nut.

1c.2 Marking

Each insulator shall be marked legibly and durably, as follows :

- (1) Manufacturer's name and/or Trade-mark
- (2) Year of manufacture.
- (3) Only for suspension insulators :
 - Tension-proof test load in kN, identified by the word "TEST".
 - Combined mechanical and electrical strength in kN, identified by the symbol "M&E, except that of class 52-1.
- (4) Only for line-post insulator and pin-post insulator : Magnitude of the power arc current in kA and duration in second, identified by the word "POWARC".
- (5) PEA's trademark, as the figure shown.



- (6) Others according to manufacturer's design.

1c.3 Sample

The bidders have to supply two (2) samples of each item of the insulators within five (5) working days counted from bid closing date. The bidders who cannot supply the requested samples shall be rejected.

PEA reserves the right to test the samples according to PEA's testing procedure. In case of the failing test results, the bidders shall be rejected.

The samples shall not be returned.



PROVINCIAL ELECTRICITY AUTHORITY

TECHNICAL SPECIFICATION DIVISION

INSULATORS

Specification No.: RINS-002/2561

Approved date: 21/05/2561

Rev. No.: 2

Form No. 01-1

Page 3 of 9

1c.4 Tests and test reports

HV insulators and LV insulators shall be passed all item of design/type tests, quality conformance tests and routine tests in accordance with the relevant TIS or ANSI or IEC.

The design/type tests for suspension insulator, line-post insulator and pin-post insulator shall conform to as follows :

(1) The proposed HV insulators shall have successfully passed the design/type test in accordance with the relevant standard.

For suspension insulator, thermal-mechanical load cycle test in accordance with the ANSI, or thermal-mechanical performance test in accordance with the IEC, shall be included.

(2) The additional acceptance criteria for determining conformance with PEA's requirements for thermal-mechanical load cycle test (or thermal-mechanical performance test) and combined mechanical and electrical strength tests (or electromechanical and mechanical failing load tests) shall be as follows :

$$\frac{\bar{R} - R_s}{S} = Q_s \geq 3$$

Where :

Q_s = Criteria of judgement for acceptance

\bar{R} = Average value obtained from the test

R_s = Rated Mechanical and Electrical strength value of the insulator

S = Standard deviation from the test

Each value measured shall not be lower than the rated Mechanical and Electrical strength; electrical puncture shall not occur before reaching ultimate failure.

Sample size shall be of ten (10) units.

The insulators shall be passed the special tests as follows :

For line-post insulator and pin-post insulator : power arc test (see Appendix 1).

For suspension insulator : steep wave front impulse test and power arc test (see Appendix 2).

If Portland cement is used in the assembly of the insulators, it shall have an autoclave expansion limit of less than 0.12 percent when tested in accordance with ASTM C 151-84 or later edition, Test method for autoclave expansion of portland cement.



PROVINCIAL ELECTRICITY AUTHORITY

TECHNICAL SPECIFICATION DIVISION

INSULATORS

Specification No.: RINS-002/2561

Approved date: 21/05/2561

Rev. No.: 2

Form No. 01-1

Page 4 of 9

The design/type tests and the special tests shall be conducted or inspected by the acknowledged testing laboratories/institutes as following:

(1) Independent laboratories/institutes which are members of the Short-circuit Testing Liaison (STL) or independent laboratories/institutes which are accredited according to TIS 17025 or ISO/IEC 17025 with the scope of accreditation covered the relevant test items, standards and equipment. The certification and scope of accreditation of the independent laboratories/institutes shall be submitted with the bid for consideration.

(2) Thailand's national laboratories, institutes, universities and electric utilities, as follows:

- National Metal and Materials Technology Center (MTEC)
- Electrical and Electronic Products Testing Center (PTEC)
- Thai Industrial Standards Institute (TISI)
- Electrical and Electronics Institute (EEI)
- Department of Science Service (DSS)
- Testing Laboratory, Electrical Engineering Department, Faculty of Engineering, Chulalongkorn University
- Electricity Generating Authority of Thailand (EGAT)
- Metropolitan Electricity Authority (MEA)
- Provincial Electricity Authority (PEA)
- Other laboratories, institutes, universities or electric utilities approved by PEA

The bidders or manufacturers who prefer to carry out the insulators with the laboratories or by the manufacturer themselves without the qualification mentioned above, the detail of the test facilities of the laboratories or the manufacturer shall be submitted to PEA for approval before proceeding the tests and before the bid closing date. PEA reserves the right to send representatives to inspect and witness the tests with the cost of the bidders or manufacturers.

The design/type test report done by the laboratories in Thailand or local manufacturers shall be valid within five (5) years counted from the issued date in the test report to the bid closing date.

The bidders have to submit the design/type test reports and/or design/type test certificates of the insulators with the bid.



PROVINCIAL ELECTRICITY AUTHORITY

TECHNICAL SPECIFICATION DIVISION

INSULATORS

Specification No.: RINS-002/2561

Approved date: 21/05/2561

Rev. No.: 2

Form No. 01-1

Page 5 of 9

PEA will also accept other documents instead of the design/type test reports and design/type test certificates in the following conditions:

- (1) In case the proposed insulators has been supplied to PEA and get the order from PEA's Procurement Department (from PEA's head office), the Purchase Order (PO) can be submitted, or
- (2) In case the proposed insulators has been registered for PEA Product Acceptance, the not-expired registration certificate counted to the bid closing date can be submitted, or
- (3) In case the proposed insulators has been registered for Product lists for substation turnkey project, the not-expired registration certificate counted to the bid closing date can be submitted instead

However the document in case (1) and (2) shall be proved that the insulators specified in the PO or registration certificate shall be the same product, type/model and all ratings as the proposed insulators for this bid and shall be used the same PEA's specification number. In case (3), the insulators specified in the registration certificate shall be the same product, type/model and all ratings as the proposed insulators for this bid.

The cost of all tests and reports shall be borne by the Bidders/Contractor.



PROVINCIAL ELECTRICITY AUTHORITY

TECHNICAL SPECIFICATION DIVISION

INSULATORS

Specification No.: RINS-002/2561

Approved date: 21/05/2561

Rev. No.: 2

Form No. 01-1

Page 6 of 9

1d Packing

Each item shall be packed in export packages in sets or pieces. The packages shall be right-square or right-rectangular forms.

The packages of same item shall be assembled into a bundle and fastened with steel bands over a pallet to make it movable by a forklift truck. The pallet shall be designed in such a manner that the truck's forks can be inserted at any side of the pallet. The steel strapped bundle shall be strong enough to withstand rough handling during transit and inland transportation and of 400 - 900 kg.

If the package is made of rubber wood (Yang-para or Hevea brasiliensis) the wooden parts shall be treated with wood preservative.

The number of sets or pieces per package and the number of packages per pallet for each item of insulators shall be as follows :

Type	PEA Material No.	Number of sets or pieces per package	Number of packages per pallet
Line – post type, class 57-2	1030010002	2	36
Line – post type, class 57-4	1030010004	1	30
Pin – post type, class 56/57-2	1030010101	2	30
Pin – post type, class 56/57-4	1030010102	1	30
Station post type TR No. 208	1030010201	2	30
Station post type TR No. 210	1030010202	2	30
Station post type TR No. 202	1030010200	3	30
Station post type TR No. 286	1030010203	1	6
Suspension type (porcelain or toughened glass), class 52-1	1030020000	6	36
Suspension type (porcelain or toughened glass), class 52-4	1030020002	6	20
Suspension type (porcelain or toughened glass), class 52-3	1030020001	6	20
Suspension type (porcelain or toughened glass), class 52-8	1030020003	6	16
Pin type, class 56-2	1030000001	4	20
Pin type, class 56-3	1030000002	4	20
Pin, fog type	1030000003	2	20
Spool type, class 53-2	1030030000	100	12
Strain type, class 54-1	1030030100	100	12
Strain type, class 54-4	1030030103	25	12



PROVINCIAL ELECTRICITY AUTHORITY

TECHNICAL SPECIFICATION DIVISION

INSULATORS

Specification No.: RINS-002/2561

Approved date: 21/05/2561

Rev. No.: 2

Form No. 01-1

Page 7 of 9

C2 Material and packing data of the insulators

The following guarantee performances and details shall be submitted with the bid:

2a For each item offered, the following details shall be submitted :

Catalogue number.

Only for HV insulators, the test certificates of design/type test and of the relevant quality conformance tests with inspector's signature.

Specifications of materials used for the component parts.

- P** Pin type
 S Suspension type
 T Spool type
 N Strain type
 L Line/pin-post type

Design data and guarantee of the proposed insulators

Type of insulators	<input type="radio"/> P	<input type="radio"/> S	<input type="radio"/> T	<input type="radio"/> N	<input type="radio"/> L
Characteristics					
ANSI Class or TIS Type or					
Dimensions					
Leakage distance	mm	mm	-	mm	mm
Protected leakage distance	-	-	-	-	mm
Dry-arcing distance	mm	-	-	-	mm
Minimum pin height	mm	-	-	-	-
Mechanical values					
Cantilever strength	kN	-	-	-	kN
Combined mechanical and electrical strength	-	kN	-	-	-
Electromechanical failing load	-	kN	-	-	-
Mechanical failing load	-	kN	-	-	-
Mechanical impact strength	-	cm-N	-	-	-
Tension proof	-	kN	-	-	-
Time load	-	kN	-	-	-
Transverse strength	-	-	kN	-	-
Tensile strength	-	-	-	kN	-
Electrical values					
Low-frequency dry flashover	kV	kV	kV	kV	kV
Low-frequency wet flashover	kV	kV	kV	kV	kV
Critical-impulse flashover, positive	kV	kV	-	-	kV
Critical-impulse flashover, negative	kV	kV	-	-	kV
Low-frequency puncture	kV	kV	-	-	-
Radio-influence-voltage data					
Low-frequency test voltage, r.m.s. to ground	kV	kV	-	-	kV
Maximum riv at 1,000 kHz	µV	µV	-	-	µV
Weight of one insulator	kg	kg	kg	kg	kg
Colour



PROVINCIAL ELECTRICITY AUTHORITY

TECHNICAL SPECIFICATION DIVISION

INSULATORS

Specification No.: RINS-002/2561

Approved date: 21/05/2561

Rev. No.: 2

Form No. 01-1

Page 8 of 9

2b For each item offered, detail drawing(s) with dimensions and tolerances in mm, showing glazed and unglazed surface and the symbol identifying the manufacturer shall be submitted.

2c Packing details

Packing method (shown by drawing(s), describe packing materials, details of wood treatment for rubber wood package)

Number of sets or pieces in each package

Dimensions (length x width x height) of each package in cm

Volume of each package in m³

Gross weight of each package in kg

Net weight of each package in kg

Number of packages

If several packages are assembled into a bundle, further details are required

Number of packages in each bundle

Dimensions (length x width x height) of each bundle in cm

Volume of each bundle in m³

Gross weight of each bundle in kg

Net weight of each bundle in kg

Number of bundles

Note : Conditions for documentation and consideration

The Contractor has to supply report of design/type tests, special tests, quality conformance tests and routine tests of the insulators in **English and/or Thai**, before shipment/delivery, to the following address:

Technical Specification Division
 Engineering Department
 Provincial Electricity Authority
 200 Ngam Wong Wan Road, Chatuchak
 Bangkok 10900
 Thailand



PROVINCIAL ELECTRICITY AUTHORITY

TECHNICAL SPECIFICATION DIVISION

INSULATORS

Specification No.: RINS-002/2561

Approved date: 21/05/2561

Rev. No.: 2

Form No. 01-1

Page 9 of 9

Critical documents of the proposed insulators shall be submitted with the bid as follows:

Item	Description of document	Confirmation	Reference (Page No./folder)
1	List of routine tests	<input type="checkbox"/> Yes <input type="checkbox"/> No	
2	Design/Type test report and/or test certificate or	<input type="checkbox"/> Yes <input type="checkbox"/> No	
	The copy of previous Purchase order (if any) or	<input type="checkbox"/> Yes <input type="checkbox"/> No	
	PEA Product Acceptance certificate (if any) or	<input type="checkbox"/> Yes <input type="checkbox"/> No	
	Product lists certificate (if any)	<input type="checkbox"/> Yes <input type="checkbox"/> No	
3	Design data and guarantee of the proposed insulators	<input type="checkbox"/> Yes <input type="checkbox"/> No	
4	Detailed drawing(s) with dimensions and tolerances in mm	<input type="checkbox"/> Yes <input type="checkbox"/> No	
5	Packing details	<input type="checkbox"/> Yes <input type="checkbox"/> No	

Note: The bidders who do not submit all critical documents mentioned in the above table with the bid will be rejected.



PROVINCIAL ELECTRICITY AUTHORITY
ELECTRICAL AND MECHANICAL ENGINEERING DIVISION

Specification No.: RINS-002/2561: INSULATORS: Page 1 of 2

C3 Schedule of detailed requirement

Invitation to Bid No.: 65IAHEB007

Item	FEA Material No.	Quantity	Description
1	1030010002	4780 set (s)	Insulator, line-post type, according to TIS 1077, Type 57-2; complete with 19 x 178 mm stud furnishing with square washer, nut, and lock nut.
2	1030010101	3250 set (s)	Insulator, pin-post type, according to TIS 1251, Type 56/57-2; complete with M20 x 178 mm stud furnishing with square washer, nut, and lock nut.
3	1030020000	3600 set (s)	Insulator, suspension type, according to TIS 354 (porcelain) Type A (Class 52-1), used in string for 22 kV system.
4	1030030000	16000 set (s)	Insulator, spool type, according to TIS 227 Type B (Class 53-2).
5	1030030103	1100 set (s)	Insulator, strain type, according to TIS 280 Type D (Class 54-4).
			<p>Note :</p> <p>1. Enclosed characteristics of insulators, detail of special tests and detail of additional routine tests as follows :</p> <p>1.1 For line post insulators</p> <p>1.1.1 Characteristics of insulators according to TIS 1077, two (2) pages.</p> <p>1.1.2 Appendix 1, details of power arc tests, two (2) pages.</p> <p>1.2 For Pin Post Insulators</p> <p>1.2.1 Characteristics of insulators according to TIS 1251, one (1) page.</p> <p>1.2.2 Appendix 1, details of power arc tests, two (2) pages</p> <p>1.3 For Suspension Insulators</p> <p>1.3.1 Characteristics of insulators according to TIS 354, TIS 563, four (4) pages.</p> <p>1.3.2 Appendix 2, details of special tests, one (1) page.</p> <p>1.3.3 Appendix 3, details of additional routine tests, one (1) page.</p> <p>1.4 For Pin Type Insulators</p> <p>Characteristics of insulators according to TIS 279, two (2) pages.</p> <p>1.5 For Fog Type Insulator</p> <p>Characteristics of insulators similar to NGK Cat. No. HRAA-025571 C, one (1) page.</p> <p>1.6 For Spool Type Insulator</p> <p>Characteristics of insulator according to TIS 227, one (1) page.</p> <p>1.7 For Strain Type Insulator</p> <p>Characteristics of insulator according to TIS 280, one (1) page.</p> <p>2. PEA reserves the right to have the test(s) on the samples which shall be performed by a third party, in Bangkok; and the costs of all test(s) and reports shall be borne by the bidders.</p>
			<p>หมายเหตุ</p> <p>1. การไฟฟ้าส่วนภูมิภาคจะพิจารณาจัดซื้อ/จัดจ้างวัสดุที่ผลิตในประเทศไทย ทั้งนี้ หากผู้เสนอราคาวัสดุที่ผลิตในประเทศไทย มีรายละเอียดคุณสมบัติเฉพาะไม่เป็นไปตามข้อกำหนดของการไฟฟ้าส่วนภูมิภาค หรือไม่มีผู้เสนอวัสดุที่ผลิตในประเทศไทย การไฟฟ้าส่วนภูมิภาคจะพิจารณาจัดซื้อ/จัดจ้างวัสดุที่ผลิตจากต่างประเทศต่อไป</p>



PROVINCIAL ELECTRICITY AUTHORITY
ELECTRICAL AND MECHANICAL ENGINEERING DIVISION

Specification No.: RINS-002/2561: INSULATORS: Page 2 of 2

C3 Schedule of detailed requirement
Invitation to Bid No.: 65IAHEB007

Item	PEA Material No.	Quantity	Description
			<p>หีสตุที่ผลิตในประเทศไทย หมายถึง ผลิตภัณฑ์ที่มีสินค้าเสร็จรูปแล้วโดยสถานที่ผลิตตั้งอยู่ในประเทศไทย</p> <ul style="list-style-type: none"> • ผลิตภัณฑ์ที่เสนอจะ ต้องเป็นผลิตภัณฑ์ที่ได้รับใบอนุญาตแสดงเครื่องหมายมาตรฐานผลิตภัณฑ์อุตสาหกรรม (มอก.) เท่านั้น (ตามรายละเอียดคุณสมบัติหีสตุเพิ่มเติม) • กำหนดส่งมอบ ที่ คลังหีสตุนครชัยศรี จ.นครปฐม ภายใน 45 วัน ทั้งนี้ให้นับถัดจากรับลงนามใบสัญญาซื้อขาย



PROVINCIAL ELECTRICITY AUTHORITY

TECHNICAL SPECIFICATION DIVISION

Specification No.: RINS-002/2561 : INSULATORS
Page 1 of 4
C3 Schedule of detailed requirement
Invitation to Bid No.:

Item	PEA Material No.	Quantity	Description
1	1030010002	set (s)	Insulator, line-post type, according to TIS 1077, Type 57-2; complete with 19 x 178 mm stud furnishing with square washer, nut, and lock nut.
2	1030010004	set (s)	Insulator, line-post type, according to TIS 1077, Type 57-4; complete with 19 x 178 mm stud furnishing with square washer, nut, and lock nut.
3	1030010101	set (s)	Insulator, pin-post type, according to TIS 1251, Type 56/57-2; complete with M20 x 178 mm stud furnishing with square washer, nut, and lock nut.
4	1030010102	set (s)	Insulator, pin-post type, according to TIS 1251, Type 56/57-4; complete with M20 x 178 mm stud furnishing with square washer, nut, and lock nut.
5	1030010201	set (s)	Insulator, station post type, for 22 kV system, according to ANSI C29.9 Technical Reference No. 208 .
6	1030010202	set (s)	Insulator, station post type, for 33 kV system, according to ANSI C29.9 Technical Reference No. 210 .
7	1030010200	set (s)	Insulator, station post type, for 115 kV system according to ANSI C29.9 Technical Reference No. 202 .
8	1030010203	set (s)	Insulator, station post type, for 115 kV system according to ANSI C29.9 Technical Reference No. 286 .
9	1030020000	set (s)	Insulator, suspension type, according to TIS 354 (porcelain) Type A (Class 52-1), used in string for 22 kV system.
10	1030020002	set (s)	Insulator, suspension type, according to TIS 354 (porcelain) Type D (Class 52-4), used in string for 22 kV and 33 kV systems.
11	1030020001	set (s)	Insulator, suspension type, according to TIS 354 (porcelain) Type C (Class 52-3), used in string for 115 kV system.
	III		



PROVINCIAL ELECTRICITY AUTHORITY
TECHNICAL SPECIFICATION DIVISION

Specification No.: RINS-002/2561 : INSULATORS

Page 2 of 4

C3 Schedule of detailed requirement

Invitation to Bid No.:

Item	PEA Material No.	Quantity	Description
12	1030020003	set (s)	Insulator, suspension type, according to TIS 354 (porcelain) Type E (Class 52-8), used in string for 115 kV system.
13	1030020000	set (s)	Insulator, suspension type, according to TIS 563 (toughened glass) Class 52-1, used in string for 22 kV system.
14	1030020002	set (s)	Insulator, suspension type, according to TIS 563 (toughened glass) Class 52-4, used in string for 22 kV and 33 kV system.
15	1030020001	set (s)	Insulator, suspension type, according to TIS 563 (toughened glass) Class 52-3, used in string for 115 kV system.
16	1030020003	set (s)	Insulator, suspension type, according to TIS 563 (toughened glass) Class 52-8, used in string for 115 kV system.
17	1030020000	set (s)	Insulator, suspension type, according to TIS 354 (porcelain) Type A (Class 52-1) or according to TIS 563 (toughened glass) Class 52-1, used in string for 22 kV system.
18	1030020002	set (s)	Insulator, suspension type, according to TIS 354 (porcelain) Type D (Class 52-4) or according to TIS 563 (toughened glass) Class 52-4, used in string for 22 kV system and 33 kV system.
19	1030020001	set (s)	Insulator, suspension type, according to TIS 354 (porcelain) Type C (Class 52-3) or according to TIS 563 (toughened glass) Class 52-3, used in string for 115 kV system.
20	1030020003	set (s)	Insulator, suspension type, according to TIS 354 (porcelain) Type E (Class 52-8) or according to TIS 563 (toughened glass) Class 52-8, used in string for 115 kV system.
21	1030000001	set (s)	Insulator, pin type, one-piece porcelain, three (3) porcelain shells, radio freed, for 22 kV system, according to TIS 279 Type B (Class 56-2) .
	III		



PROVINCIAL ELECTRICITY AUTHORITY
TECHNICAL SPECIFICATION DIVISION

Specification No.: RINS-002/2561 : INSULATORS

Page 3 of 4

C3 Schedule of detailed requirement

Invitation to Bid No.:

Item	PEA Material No.	Quantity	Description
22	1030000002	set (s)	Insulator, pin type, radio freed, for 33 kV system, according to TIS 279 Type C (Class 56-3).
23	1030000003	set (s)	Insulator, pin, fog type, radio freed, ANSI 1 3/8" diameter pin hole, similar to NGK Cat. No. HRAA-025571 C.
24	1030030000	set (s)	Insulator, spool type, according to TIS 227 Type B (Class 53-2).
25	1030030100	set (s)	Insulator, strain type, according to TIS 280 Type A (Class 54-1).
26	1030030103	set (s)	Insulator, strain type, according to TIS 280 Type D (Class 54-4).
			<p><u>Note :</u></p> <p>1. Enclosed characteristics of insulators, detail of special tests and detail of additional routine tests as follows :</p> <p>1.1 <u>For line post insulators</u></p> <p style="padding-left: 20px;">1.1.1 Characteristics of insulators according to TIS 1077, two (2) pages.</p> <p style="padding-left: 20px;">1.1.2 Appendix 1, details of power arc tests, two (2) pages.</p> <p>1.2 <u>For Pin Post Insulators</u></p> <p style="padding-left: 20px;">1.2.1 Characteristics of insulators according to TIS 1251, one (1) page.</p> <p style="padding-left: 20px;">1.2.2 Appendix 1, details of power arc tests, two (2) pages</p> <p>1.3 <u>For Suspension Insulators</u></p> <p style="padding-left: 20px;">1.3.1 Characteristics of insulators according to TIS 354, TIS 563, four (4) pages.</p> <p style="padding-left: 20px;">1.3.2 Appendix 2, details of special tests, one (1) page.</p> <p style="padding-left: 20px;">1.3.3 Appendix 3, details of additional routine tests, one (1) page.</p> <p>1.4 <u>For Pin Type Insulators</u></p> <p style="padding-left: 20px;">Characteristics of insulators according to TIS 279, two (2) pages.</p> <p>1.5 <u>For Fog Type Insulator</u></p> <p style="padding-left: 20px;">Characteristics of insulators similar to NGK Cat. No. HRAA-025571 C, one (1) page.</p>
III			Issued by SmartSpec Date: 14/06/22



PROVINCIAL ELECTRICITY AUTHORITY

TECHNICAL SPECIFICATION DIVISION

Specification No.: RINS-002/2561 : INSULATORS

Page 4 of 4

C3 Schedule of detailed requirement

Invitation to Bid No.:

Item	PEA Material No.	Quantity	Description
			<p>1.6 <u>For Spool Type Insulator</u> Characteristics of insulator according to TIS 227, one (1) page.</p> <p>1.7 <u>For Strain Type Insulator</u> Characteristics of insulator according to TIS 280, one (1) page.</p> <p>2. PEA reserves the right to have the test(s) on the samples which shall be performed by a third party, in Bangkok; and the costs of all test(s) and reports shall be borne by the bidders.</p>
	III		



**PROVINCIAL ELECTRICITY AUTHORITY
TECHNICAL SPECIFICATION DIVISION**

Specification No.: RINS-002/2561 : INSULATORS

Page 1 of 5

C4 Price schedule

Invitation to Bid No.:

Manufacturer :

Country of origin :

Trade-mark :

Item	PEA Material No.	Catalogue No.	Description	Quantity	Unit Cost (See details & conditions attached)	Total Cost (See details & conditions attached)
1	1030010002		Insulator, line-post type, according to TIS 1077, Type 57-2; complete with 19 x 178 mm stud furnishing with square washer, nut, and lock nut.	set (s)		
2	1030010004		Insulator, line-post type, according to TIS 1077, Type 57-4; complete with 19 x 178 mm stud furnishing with square washer, nut, and lock nut.	set (s)		
3	1030010101		Insulator, pin-post type, according to TIS 1251, Type 56/57-2; complete with M20 x 178 mm stud furnishing with square washer, nut, and lock nut.	set (s)		
4	1030010102		Insulator, pin-post type, according to TIS 1251, Type 56/57-4; complete with M20 x 178 mm stud furnishing with square washer, nut, and lock nut.	set (s)		
5	1030010201		Insulator, station post type, for 22 kV system, according to ANSI Technical Reference No. 208 .	set (s)		
6	1030010202		Insulator, station post type, for 33 kV system, according to ANSI Technical Reference No. 210 .	set (s)		
	III					



PROVINCIAL ELECTRICITY AUTHORITY
TECHNICAL SPECIFICATION DIVISION

Specification No.: RINS-002/2561 : INSULATORS

Page 2 of 5

C4 Price schedule

Invitation to Bid No.:

Manufacturer :

Country of origin :

Trade-mark :

Item	PEA Material No.	Catalogue No.	Description	Quantity	Unit Cost (See details & conditions attached)	Total Cost (See details & conditions attached)
7	1030010200		Insulator, station post type, for 115 kV system according to ANSI Technical Reference No. 202 .	set (s)		
8	1030010203		Insulator, station post type, for 115 kV system according to ANSI Technical Reference No. 286 .	set (s)		
9	1030020000		Insulator, suspension type, according to TIS 354 (porcelain) Type A (Class 52-1), used in string for 22 kV system.	set (s)		
10	1030020002		Insulator, suspension type, according to TIS 354 (porcelain) Type D (Class 52-4), used in string for 22 kV and 33 kV systems.	set (s)		
11	1030020001		Insulator, suspension type, according to TIS 354 (porcelain) Type C (Class 52-3), used in string for 115 kV system.	set (s)		
12	1030020003		Insulator, suspension type, according to TIS 354 (porcelain) Type E (Class 52-8), used in string for 115 kV system.	set (s)		
III						



PROVINCIAL ELECTRICITY AUTHORITY
TECHNICAL SPECIFICATION DIVISION

Specification No.: RINS-002/2561 : INSULATORS

Page 3 of 5

C4 Price schedule

Invitation to Bid No.:

Manufacturer :

Country of origin :

Trade-mark :

Item	PEA Material No.	Catalogue No.	Description	Quantity	Unit Cost (See details & conditions attached)	Total Cost (See details & conditions attached)
13	1030020000		Insulator, suspension type, according to TIS 563 (toughened glass) Class 52-1, used in string for 22 kV system.	set (s)		
14	1030020002		Insulator, suspension type, according to TIS 563 (toughened glass) Class 52-4, used in string for 22 kV and 33 kV system.	set (s)		
15	1030020001		Insulator, suspension type, according to TIS 563 (toughened glass) Class 52-3, used in string for 115 kV system.	set (s)		
16	1030020003		Insulator, suspension type, according to TIS 563 (toughened glass) Class 52-8, used in string for 115 kV system.	set (s)		
17	1030020000		Insulator, suspension type, according to TIS 354 (porcelain) Type A (Class 52-1) or according to TIS 563 (toughened glass) Class 52-1, used in string for 22 kV system.	set (s)		
	III					



PROVINCIAL ELECTRICITY AUTHORITY
TECHNICAL SPECIFICATION DIVISION

Specification No.: RINS-002/2561 : INSULATORS

Page 4 of 5

C4 Price schedule

Invitation to Bid No.:

Manufacturer :

Country of origin :

Trade-mark :

Item	PEA Material No.	Catalogue No.	Description	Quantity	Unit Cost (See details & conditions attached)	Total Cost (See details & conditions attached)
18	1030020002		Insulator, suspension type, according to TIS 354 (porcelain) Type D (Class 52-4) or according to TIS 563 (toughened glass) Class 52-4, used in string for 22 kV system and 33 kV system.	set (s)		
19	1030020001		Insulator, suspension type, according to TIS 354 (porcelain) Type C (Class 52-3) or according to TIS 563 (toughened glass) Class 52-3, used in string for 115 kV system.	set (s)		
20	1030020003		Insulator, suspension type, according to TIS 354 (porcelain) Type E (Class 52-8) or according to TIS 563 (toughened glass) Class 52-8, used in string for 115 kV system.	set (s)		
21	1030000001		Insulator, pin type, one-piece porcelain, three (3) porcelain shells, radio freed, for 22 kV system, according to TIS 279 Type B (Class 56-2).	set (s)		
22	1030000002		Insulator, pin type, radio freed, for 33 kV system, according to TIS 279 Type C (Class 56-3).	set (s)		
	III					



PROVINCIAL ELECTRICITY AUTHORITY
TECHNICAL SPECIFICATION DIVISION

Specification No.: RINS-002/2561 : INSULATORS

Page 5 of 5

C4 Price schedule

Invitation to Bid No.:

Manufacturer :

Country of origin :

Trade-mark :

Item	PEA Material No.	Catalogue No.	Description	Quantity	Unit Cost (See details & conditions attached)	Total Cost (See details & conditions attached)
23	1030000003		Insulator, pin, fog type, radio freed, ANSI 1 3/8" diameter pin hole, similar to NGK Cat. No. HRAA-025571 C.	set (s)		
24	1030030000		Insulator, spool type, according to TIS 227 Type B (Class 53-2).	set (s)		
25	1030030100		Insulator, strain type, according to TIS 280 Type A (Class 54-1).	set (s)		
26	1030030103		Insulator, strain type, according to TIS 280 Type D (Class 54-4).	set (s)		
III						



PROVINCIAL ELECTRICITY AUTHORITY

TECHNICAL SPECIFICATION DIVISION

Appendix 1

Power arc tests for line post/pin post type insulator

1. Test arrangement

The test arrangement shall be as shown in Drawing No. SA2-015/35042.

The power arc test shall be carried out in three-phase with three specimens simultaneously.

2. Power supply

The power supply shall be adequate to maintain the specified arc current for the specified duration. The arc current shall be practically sinusoidal and constant, and shall not deviate from the specified value by more than 10% during the test.

For long arc durations (greater than 20 cycles), the variation of the arc current may be greater than 10%, in this case, the arc current may be evaluated by its average peak value during the test duration.

The supply frequency shall be the rated frequency of 50 Hz or 60 Hz.

3. Arc initiation

The arc shall be initiated by means of a fuse wire of suitable diameter attached to the insulator as shown in detail "A" in Drawing No. SA2-015/35042.

4. Characteristics of the power arcs

The number, current, and duration of the power arcs to be applied to each set shall be as shown in the table below:

Type of Insulator		57-2 and 56/57-2		57-4 and 56/57-4	
		1	1	1	1
Number		1	1	1	1
Minimum test current, r.m.s.	kA	10	3	10	3
Minimum duration	sec	0.40	0.65	0.40	0.79

5. Evaluation of the results

The insulators shall be considered to have passed the tests if there is no partial shed breakage on any insulators as the result of the power arc test.

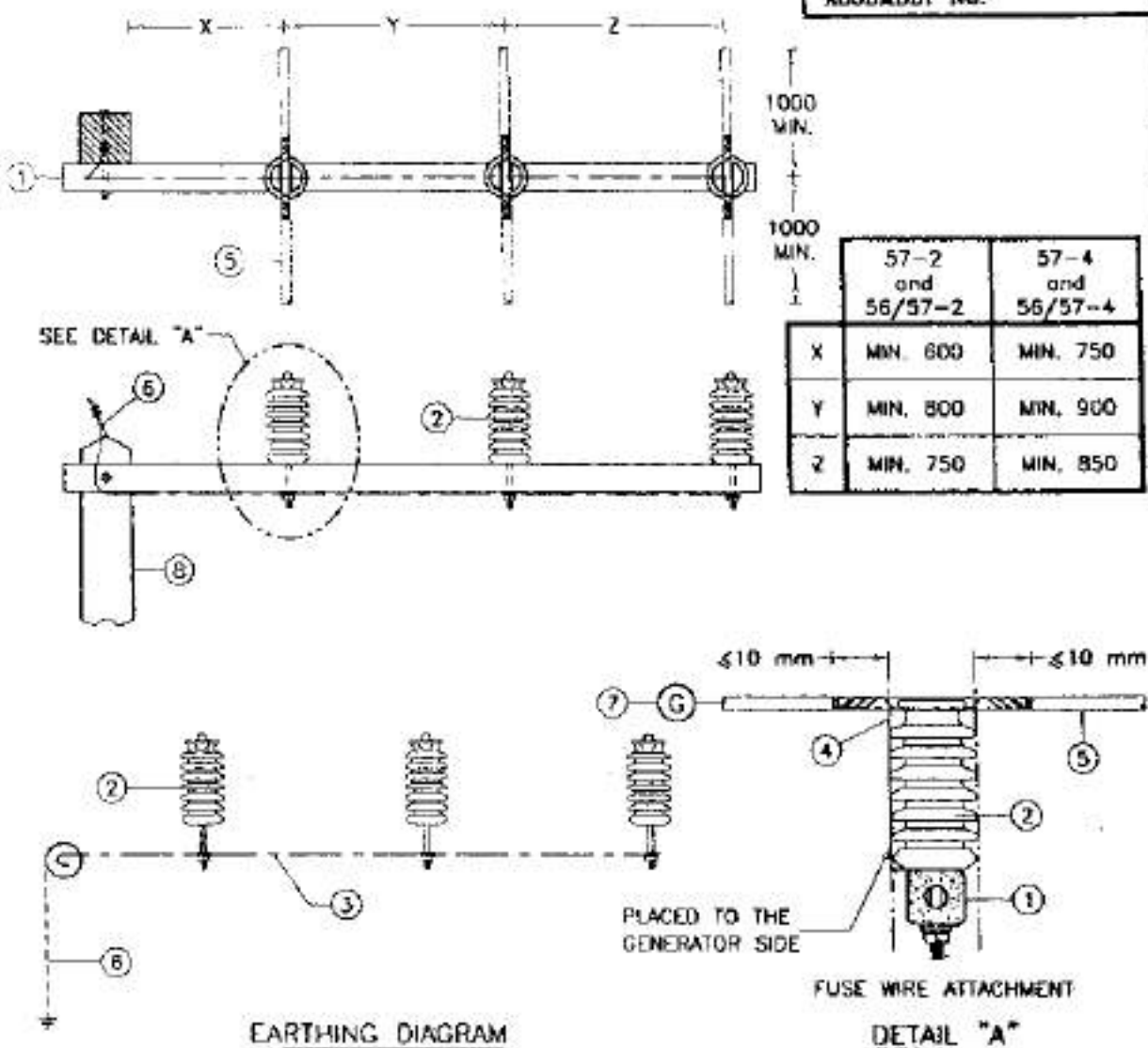

NOTES

- ① CONCRETE CROSSARM, THE CROSSARM CAN BE REPLACED BY A STEEL CHANNEL.
- ② INSULATOR.
- ③ STEEL WIRE, SOLID, DIAMETER OF 4 mm, IF ANY.
- ④ FUSE WIRE, PLACED TO THE GENERATOR SIDE.
- ⑤ COVERED CONDUCTOR.
- ⑥ STEEL STRANDED WIRE, DIAMETER OF 6.3 mm (BURIED IN CONCRETE POLE), IF ANY.
- ⑦ SHORT-CIRCUIT GENERATOR.
- ⑧ CONCRETE POLE, THE POLE CAN BE REPLACED BY A STEEL POLE, IF ANY.

<p>กองช่างการไฟฟ้าส่วนภูมิภาค ฝ่ายวิศวกรรม</p>	<p>การไฟฟ้าส่วนภูมิภาค</p>	<p>ใช้แบบ..... ชุดทาบ.....</p>
<p>ผู้เขียน..... ผู้ตรวจ..... ผู้ควบคุมงาน..... ผู้ดำเนินการ.....</p>	<p>ผู้ตรวจ.....</p> <p>POWER ARC TEST ARRANGMENT FOR INSULATORS, FOR OVERHEAD LINES</p>	<p>เขียนเสร็จวันที่..... ฉบับที่..... ฉบับ..... หน้ากระดาษ.....</p>
<p>งานพิมพ์.....</p>		<p>แบบที่ SA2-013/350-02 วันที่ 1 ธันวาคม 2552</p>

PSD



PROVINCIAL ELECTRICITY AUTHORITY

TECHNICAL SPECIFICATION DIVISION

Appendix 2

Special tests for suspension insulators

(class 52-1, 52-4, 52-3 and 52-8)

The special tests are as follows :

1. Steep wave front impulse test

The test shall be performed on ten (10) units of insulator selected at random.

The insulator shall be subject to ten (10) successive positive and negative impulse flashovers with a wave having an effective rate of rise of 2,500 kV/ μ s. The insulators shall be tested singly.

Each unit shall then be verified to be electrically intact by applying low-frequency voltage, dry or wet.

In case of wet test, the rated wet low-frequency withstand voltage shall be applied to each unit and no electrical puncture shall occur.

In case of dry test, the five (5) flashovers of the low-frequency dry flashover test in accordance with the ANSI C29.1 shall be applied and shall have a flashover value of not less than 95% of the rated value.

Failure of any one (1) unit either in the front-of-wave test or subsequent low frequency withstand voltage test shall cause for testing another twenty (20) units.

Failure of more than one (1) unit from total so tested shall constitute failure of this insulator design and will not meet requirements of these specifications.

2. Power arc test

Nine (9) insulator units of each type, in 3-unit strings, mounted vertically without arcing horns or conductors, shall be subject to power arcs of 12 kA r.m.s., symmetrical for 0.1 seconds and of 6 kA r.m.s., symmetrical for 0.2 seconds.

The insulator string shall withstand the power arc without shell breakage. Failure of any one (1) string in the test shall be caused for testing another three (3) strings of the same type.

Failure of more than one (1) string from the total so tested shall constitute failure of this insulator design and will not meet requirements of these specifications.



PROVINCIAL ELECTRICITY AUTHORITY

TECHNICAL SPECIFICATION DIVISION

Appendix 3

Additional routine tests for porcelain suspension insulators

(class 52-1, 52-4, 52-3 and 52-8)

The additional routine tests are as follows :

1. Hydraulic inner pressure test

The test shall be performed by injecting water into porcelain head portion for at least 2.5 second. The water pressure shall be as follows :

Suspension insulator Class	Minimum water pressure Kg/cm ²
52-1	80
52-4	140
52-3	140
52-8	180

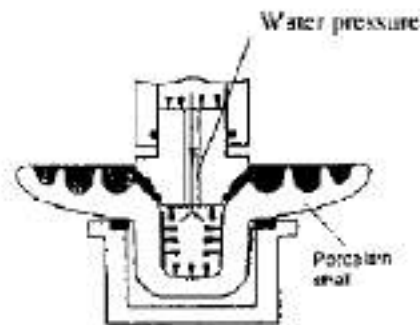

Hydraulic inner pressure test

2. High – frequency test follow by low – frequency test

Not withstanding those specified in ANSI C29.2, routine flashover test of suspension insulator shall be performed by applied high-frequency test 100 – 500 kHz for at least 3 seconds follow by low – frequency test for at least 3 minutes.

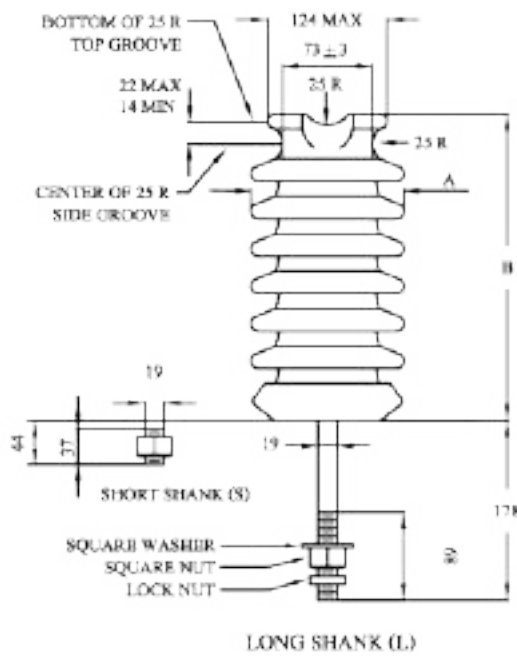

Note

1. Dimensions not specifying tolerances are only references.
2. See Fig 6 in TIS 1077, for base threading.
3. All dimensions are in mm.
4. Top-wire groove shall seat a 50 mm diameter mandrel.
5. Side-wire groove shall seat a 50 mm diameter mandrel.

57-2

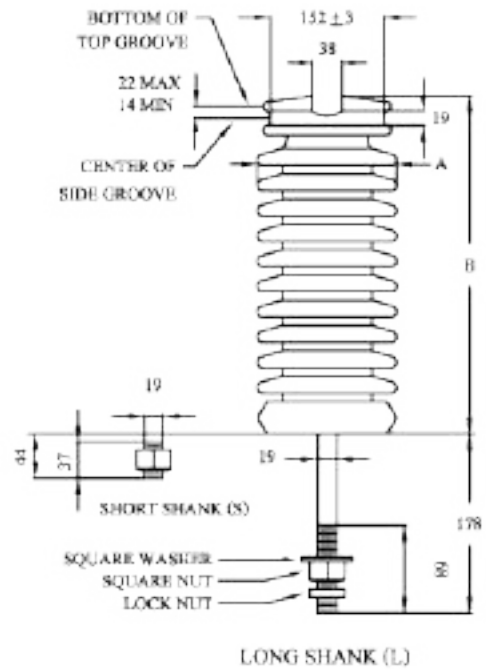

Note

1. Dimensions not specifying tolerances are only references.
2. See Fig 6 in TIS 1077, for base threading.
3. All dimensions are in mm.
4. Top-wire groove shall seat a 37 mm diameter mandrel.

57-4

TIS 1077 LINE-POST INSULATOR			57-2	57-4
DIMENSIONS	Leakage distance, minimum	mm	559	1,015
	Protected leakage distance, minimum	mm	224	406
	Dry-arcing distance, minimum	mm	241	368
	A	mm	152	178
	B	mm	305	432
MECHANICAL VALUES	Cantilever strength	kN	12.5	12.5
	Cantilever proof load	kN	5	5
ELECTRICAL VALUES	Low-frequency dry flashover	kV	110	150
	Low-frequency wet flashover	kV	85	125
	Critical-impulse flashover, positive	kV	180	255
	Critical-impulse flashover, negative	kV	205	340
RADIO-INFLUENCE VOLTAGE DATA	Low-frequency test voltage, rms to ground	kV	22	44
	Maximum RIV at 1,000 kHz, Radio freed	µV	100	200
COLOUR OF INSULATOR			Preferably	BROWN

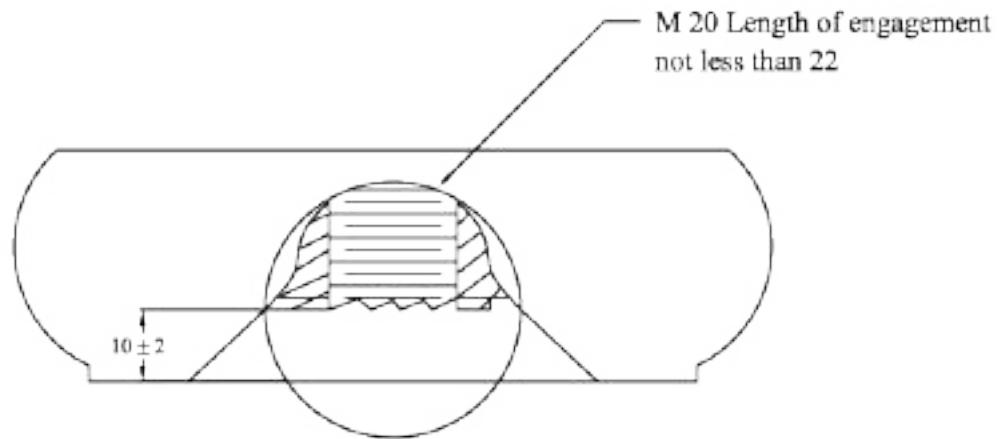

All dimensions are in mm

Fig. 6 in TIS 1077

Base Recess and Thread Dimensions

FOR LINE - POST INSULATOR ONLY

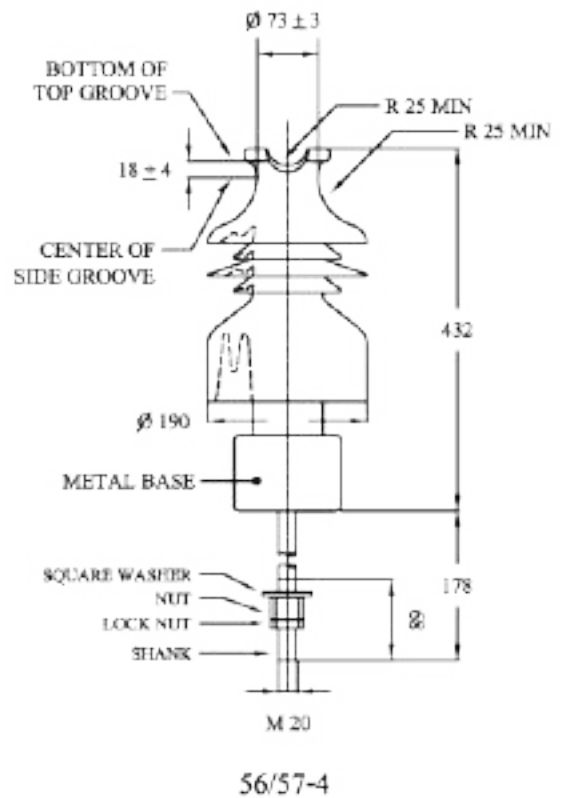
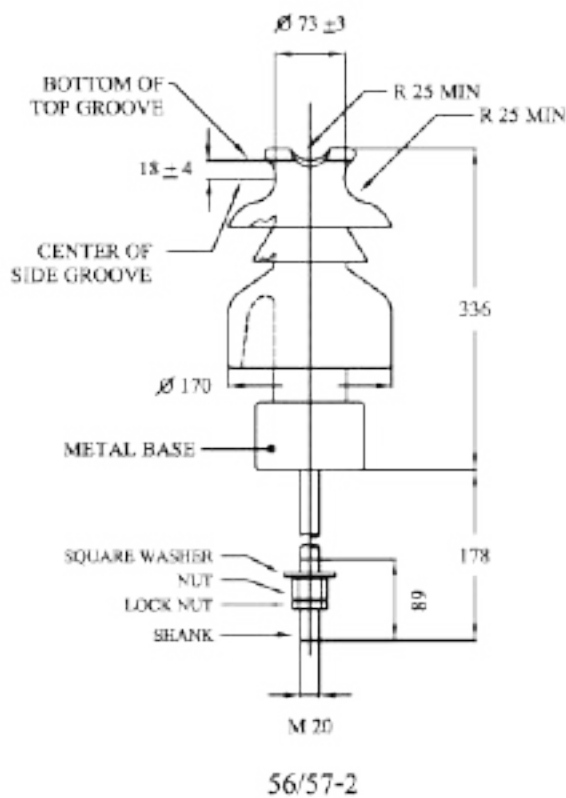

Note

1. Dimensions not specifying tolerances are only references.
2. All dimensions are in mm.
3. Top-wire groove shall seat a 50 mm diameter mandrel.
4. Side-wire groove shall seat a 50 mm diameter mandrel.

TIS 1251 PIN-POST INSULATOR			56/57-2	56/57-4
DIMENSIONS	Leakage distance, minimum	mm	534	953
	Protected leakage distance, minimum	mm	267	483
MECHANICAL VALUES	Cantilever strength	kN	12.5	12.5
	Cantilever proof load	kN	5	5
ELECTRICAL VALUES	Low-frequency dry flashover	kV	110	140
	Low-frequency wet flashover	kV	80	95
	Critical-impulse flashover, positive	kV	180	225
	Critical-impulse flashover, negative	kV	205	300
RADIO-INFLUENCE VOLTAGE DATA	Low-frequency test voltage, rms to ground	kV	22	44
	Maximum RIV at 1,000 kHz, Radio freed	µV	100	200
COLOUR OF INSULATOR	Preferably	BROWN		

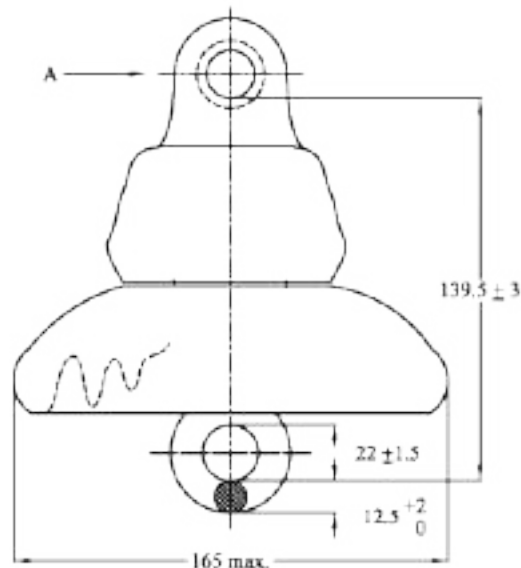

Class 52-1

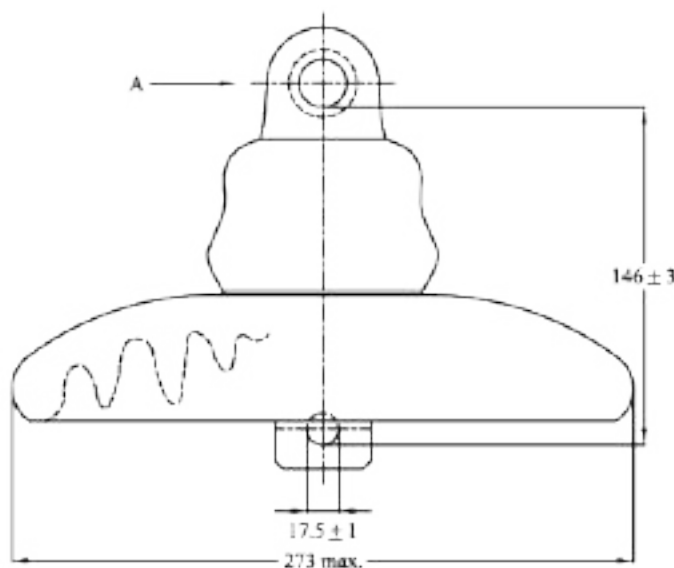
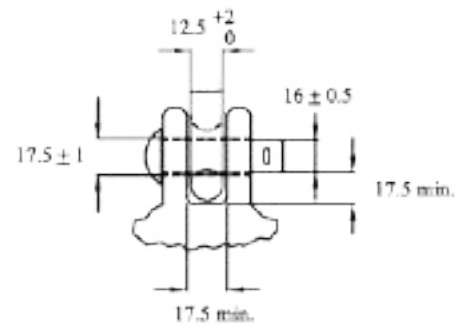

Class 52-4

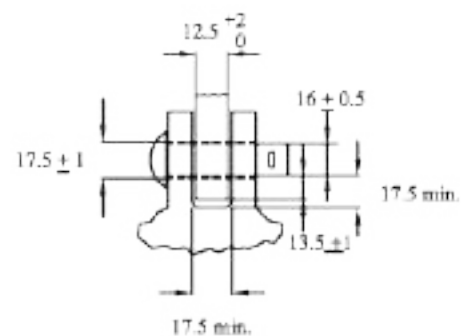

All dimensions are in mm

TIS 354 SUSPENSION-TYPE PORCELAIN INSULATOR		Type A Class 52-1	Type D Class 52-4
MINIMUM DIMENSIONS	Leakage distance	mm	178
			292
MECHANICAL VALUES	Combined mechanical and electrical strength	mm	44.48
	Mechanical impact strength	cm-N	507.37
	Tension proof	kN	22.24
	Time load	kN	44.48
ELECTRICAL VALUES	Low-frequency dry flashover	kV	60
	Low-frequency wet flashover	kV	30
	Critical-impulse flashover, positive	kV	100
	Critical-impulse flashover, negative	kV	130
	Low-frequency puncture	kV	80
RADIO-INFLUENCE VOLTAGE DATA	Low-frequency test voltage, rms to ground	kV	7.5
	Maximum RIV at 1,000 kHz	µV	50
COLOUR OF INSULATOR		BROWN	

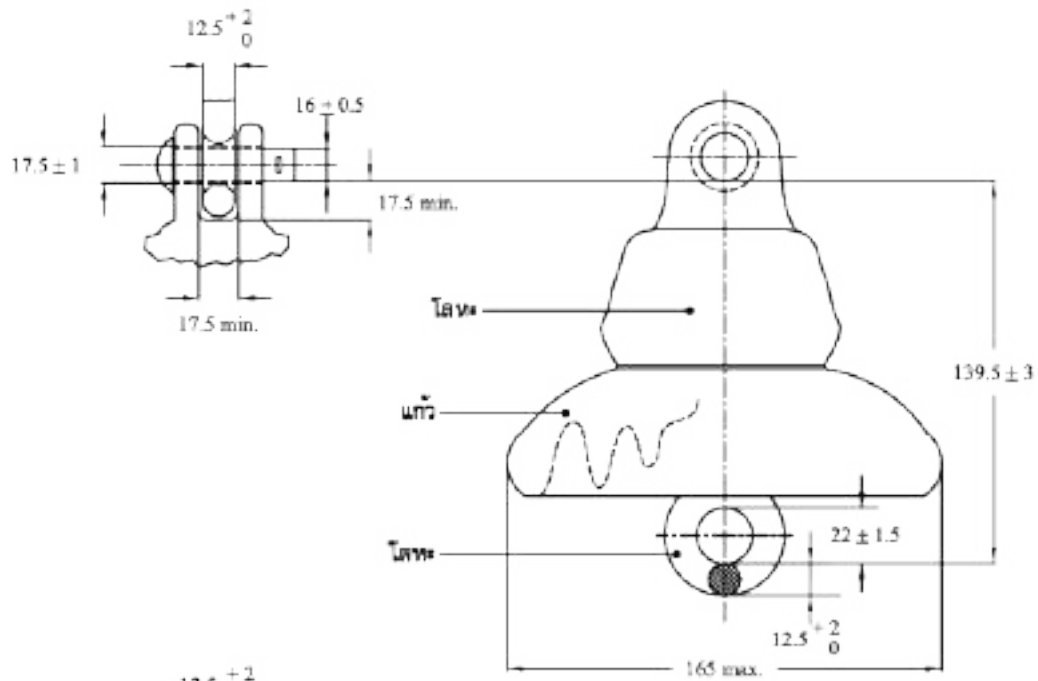

Class 52-1

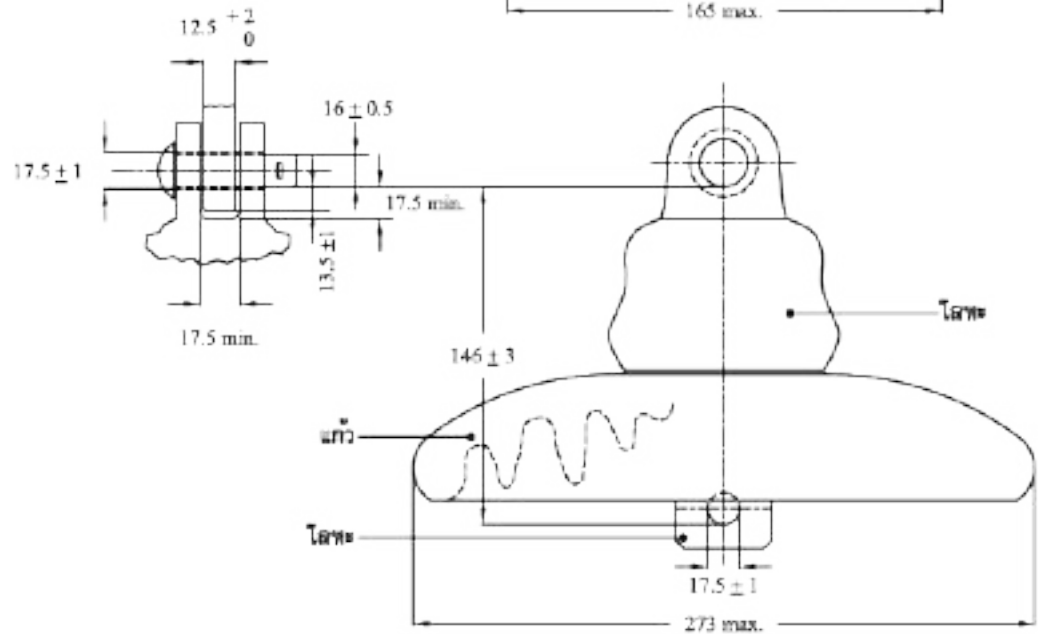

Class 52-4

All dimensions are in mm

TIS 563 SUSPENSION-TYPE TOUGHENED GLASS INSULATOR		Class 52-1	Class 52-4	
MINIMUM DIMENSIONS	Leakage distance	mm	178	292
	Combined mechanical and electrical strength	mm	44	67
MECHANICAL VALUES	Mechanical impact strength	N-m	5.0	6.0
	Tension proof	kN	22	33.5
	Time load	kN	27	44
	Low-frequency dry flashover	kV	60	80
ELECTRICAL VALUES	Low-frequency wet flashover	kV	30	50
	Critical-impulse flashover, positive	kV	100	125
	Critical-impulse flashover, negative	kV	100	130
	Low-frequency puncture	kV	80	110
	RADIO-INFLUENCE VOLTAGE DATA	Low-frequency test voltage, rms to ground	kV	7.5
Maximum RIV at 1,000 kHz		µV	50	50

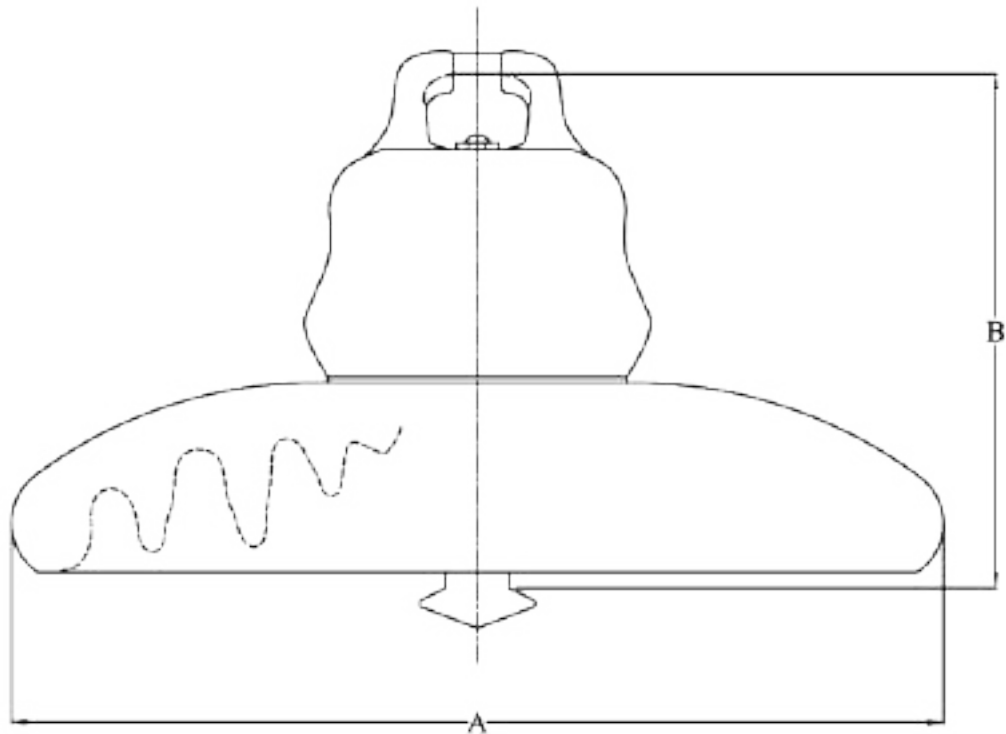

TIS 354 SUSPENSION-TYPE PORCELAIN INSULATOR		Type C Class 52-3	Type E Class 52-8	
DIMENSIONS	A, maximum	mm	273	298
	B	mm	146 ₊₃	146 ₊₃
MINIMUM DIMENSIONS	Leakage distance	mm	292	279.5
MECHANICAL VALUES	Combined mechanical and electrical strength	kN	66.72	160.13
	Mechanical impact strength	cm-N	621.34	1,016.73
	Tension proof	kN	33.36	80.06
	Time load	kN	44.48	106.75
ELECTRICAL VALUES	Low-frequency dry flashover	kV	80	80
	Low-frequency wet flashover	kV	50	50
	Critical-impluse flashover, positive	kV	125	125
	Critical-impluse flashover, negative	kV	130	130
	Low-frequency puncture	kV	110	110
RADIO-INFLUENCE VOLTAGE DATA	Low-frequency test voltage, rms to ground	kV	10	10
	Maximum RIV at 1,000 kHz	μV	50	50
COLOUR OF INSULATOR		BROWN		

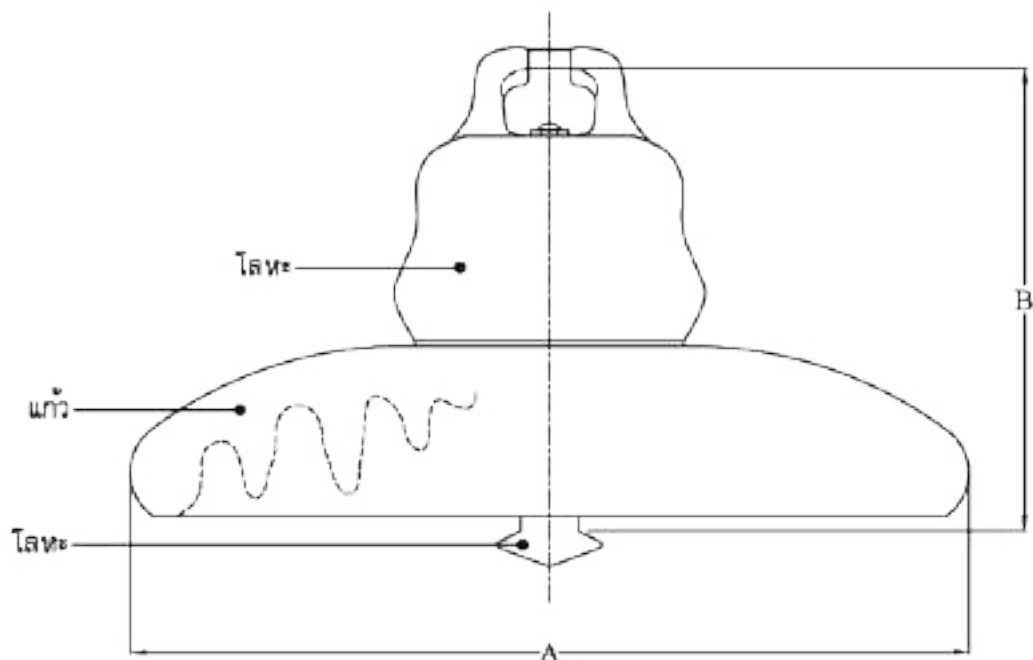

TIS 563 SUSPENSION-TYPE TOUGHENED GLASS INSULATOR		Class 52-3	Class 52-8	
DIMENSIONS	A, maximum	mm	273	298
	B	mm	146±3	146±3
MINIMUM DIMENSIONS	Leakage distance	mm	292	279
MECHANICAL VALUES	Combined mechanical and electrical strength	kN	67	160
	Mechanical impact strength	cm-N	6.0	10
	Tension proof	kN	33.5	80
	Time load	kN	44	107
ELECTRICAL VALUES	Low-frequency dry flashover	kV	80	80
	Low-frequency wet flashover	kV	50	50
	Critical-impluse flashover, positive	kV	125	125
	Critical-impluse flashover, negative	kV	130	130
	Low-frequency puncture	kV	110	110
RADIO-INFLUENCE VOLTAGE DATA	Low-frequency test voltage, rms to ground	kV	10	10
	Maximum RIV at 1,000 kHz	µV	50	50

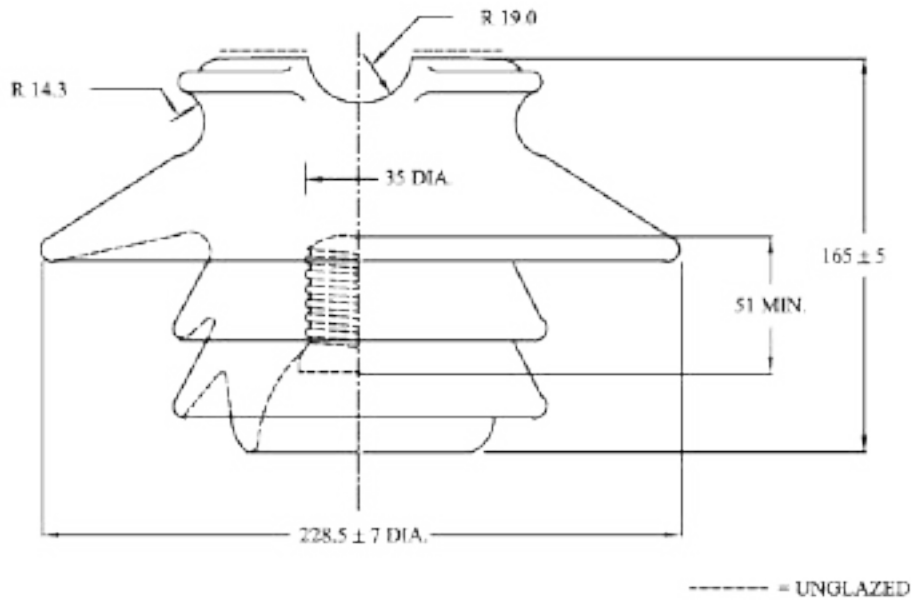

Note

1. If high-resistance coatings are applied to the insulator, such coatings shall be considered as effective leakage surfaces, and the distance over them shall be included in the leakage distance.
2. All dimensions are in mm.
3. Top-wire groove shall seat a 36.5 mm diameter mandrel.
4. Side-wire groove shall seat a 27 mm diameter mandrel.

TIS 279 PIN-TYPE INSULATOR			Type B Class 56-2
MINIMUM DIMENSIONS	Leakage Distance	mm	432
	Dry-arcing distance	mm	210
	Pin height	mm	178
MECHANICAL VALUE	Cantilever strength	kN (lb)	13.3 (3,000)
ELECTRICAL VALUES	Low-frequency dry flashover	kV	110
	Low-frequency wet flashover	kV	70
	Critical-impulse flashover, positive	kV	175
	Critical-impulse flashover, negative	kV	225
	Low-frequency puncture	kV	145
RADIO-INFLUENCE VOLTAGE DATA	Low-frequency test voltage, rms to ground	kV	22
	Maximum RIV at 1,000 kHz, Radio freed	µV	100
COLOUR OF INSULATOR			BROWN

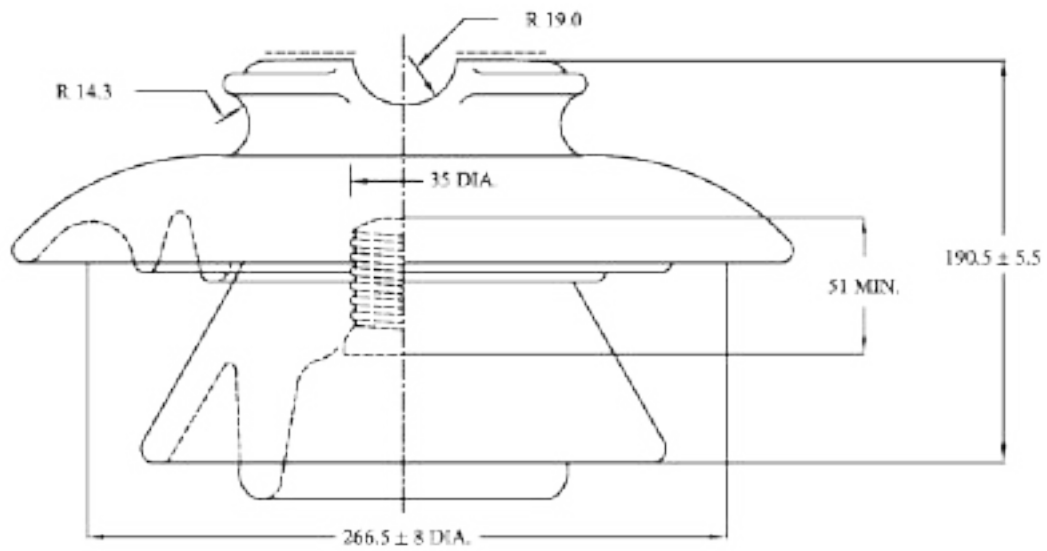

----- = UNGLAZED

Note

1. If high-resistance coatings are applied to the insulator, such coatings shall be considered as effective leakage surfaces, and the distance over them shall be included in the leakage distance.
2. All dimensions are in mm.
3. Top-wire groove shall seat a 35 mm diameter mandrel.
4. Side-wire groove shall seat a 27 mm diameter mandrel.

TIS 279 PIN-TYPE INSULATOR			Type C Class 56-3
MINIMUM DIMENSIONS	Leakage distance	mm	533.5
	Dry-arcing distance	mm	241.5
	Pin height	mm	203
MECHANICAL VALUE	Cantilever strength	kN (lb)	13.3 (3,000)
ELECTRICAL VALUES	Low-frequency dry flashover	kV	125
	Low-frequency wet flashover	kV	80
	Critical-impulse flashover, positive	kV	200
	Critical-impulse flashover, negative	kV	265
	Low-frequency puncture	kV	165
RADIO-INFLUENCE VOLTAGE DATA	Low-frequency test voltage, rms to ground	kV	30
	Maximum RIV at 1,000 kHz, Radio freed	µV	200
COLOUR OF INSULATOR			BROWN

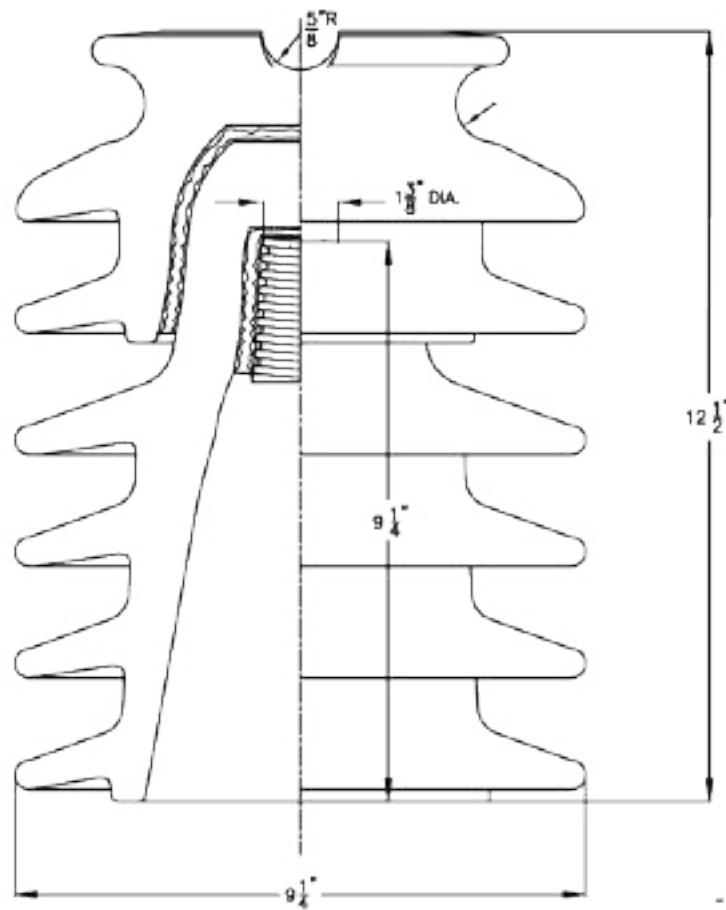

----- UNGLAZED
 CATALOGUE NO. HRAA-025571C

Catalogue No.		HRAA-025571C		
Leakage Distance		inch	36 3/4	
Dry Arcing Distance		inch	14 1/4	
Cantiliver strength		lb	3,000	
Minimum Flashover Volage	Low Frequency	Dry	kV	140
		Wet	kV	115
	Critical Impluse	Positive	kV	210
		Negative	kV	245
Withstand Voltage	Low Frequency	Dry	kV	120
		Wet	kV	90
	Critical Impluse	kV	190	
Low Frequency Puncture Voltage		kV	210	
Radio Influence Voltage Data	Test Voltage to Ground		kV	30
	Maximum RIV at 1,000 kHz		µV	200
COLOUR OF INSULATOR				BROWN

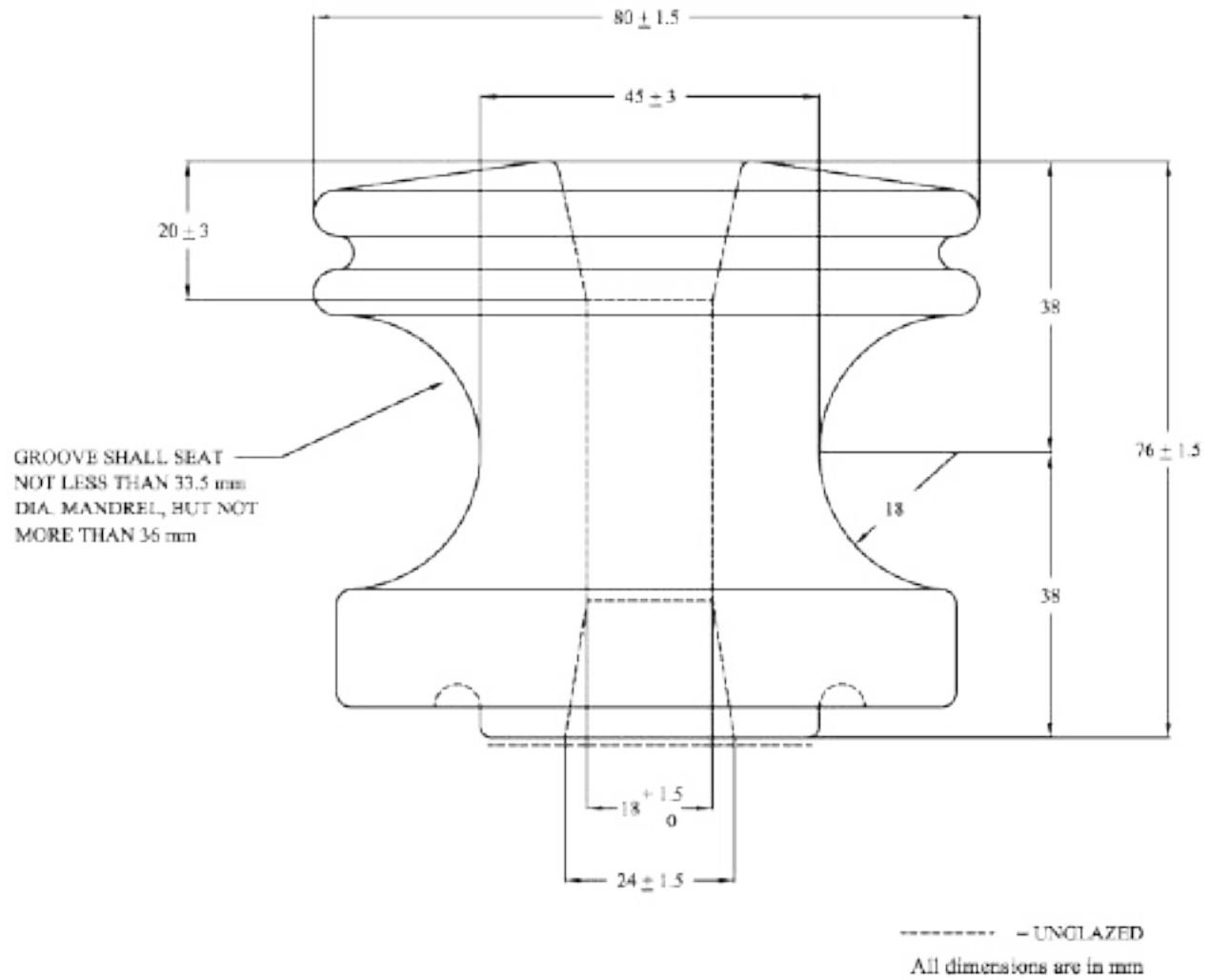

TIS 227 SPOOL-TYPE INSULATOR			Type B Class 53-2
MECHANICAL VALUE	Transverse strength	kN (lb)	13.3 (3,000)
ELECTRICAL VALUES	Low-frequency dry flashover	kV	25
	Low-frequency wet flashover, Vertical	kV	12
	Low-frequency wet flashover, Horizontal	kV	15
COLOUR OF INSULATOR			BROWN

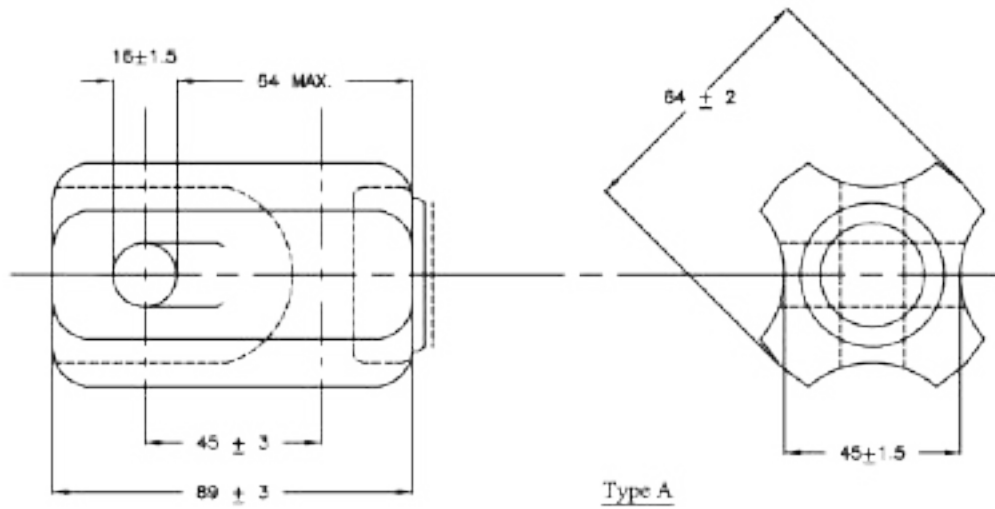

Type A

----- UNGLAZED
All dimensions are in mm

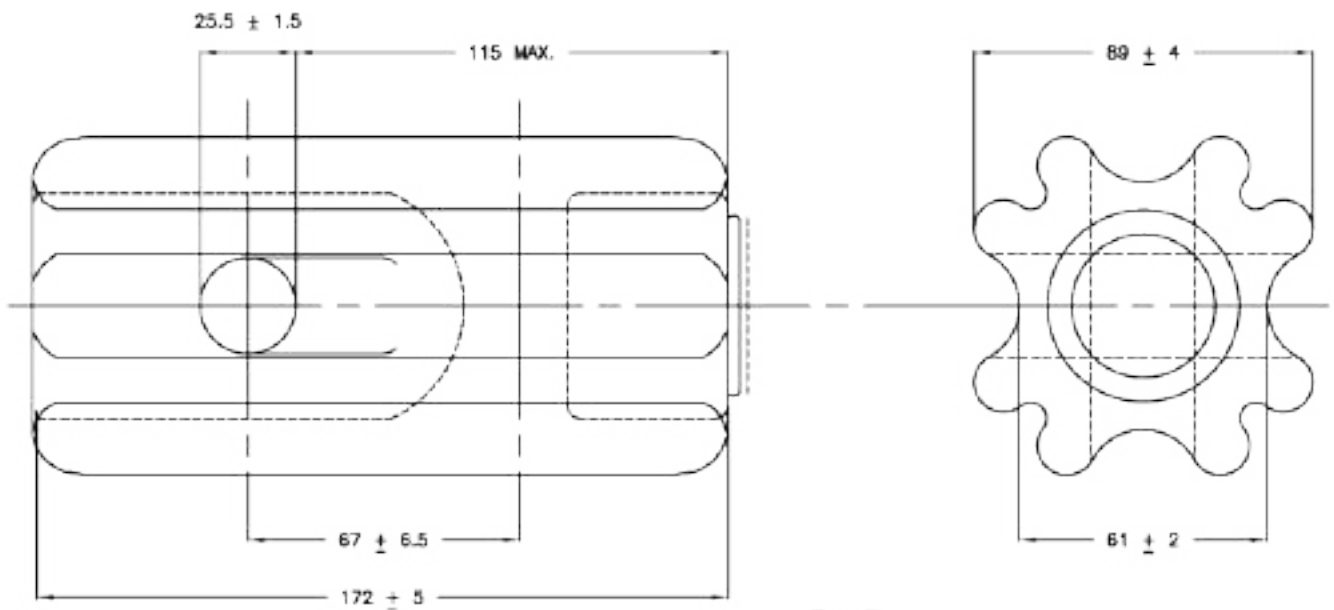

Type D

----- UNGLAZED
All dimensions are in mm

TIS 280 STRAIN-TYPE INSULATOR			Type A Class 54-1	Type D Class 54-4
MINIMUM DIMENSIONS	Leakage distance	mm	41.5	76
MECHANICAL VALUES	Tension strength	kN (lb)	44.5 (10,000)	89 (20,000)
ELECTRICAL VALUES	Low-frequency dry flashover	kV	25	40
	Low-frequency wet flashover	kV	12	23
COLOUR OF INSULATOR			BROWN	